



2013 Daikin All Products Catalog
Commercial, Industrial and Institutional HVAC

Engineered for flexibility and performance™

Table of Contents

About Us	4	Condensing Units/Condensers/Fluid Coolers	95
Innovation and Sustainability	5	Single Circuit Air-Cooled Scroll Condensing Units	
World Class Applied Development Center	5	—6 to 20 Tons	96
World Class Sustainability—ours and yours	5	Single Circuit Air-Cooled Scroll Condensing Units	
Industry Leadership	6	—10 to 39 Tons	99
Daikin Solutions Plaza Daikin	6	Dual Circuit Air-Cooled Scroll Condensing Units	
McQuay Learning Institute	6	—15 to 140 Tons	102
Design Solutions – Software Tools	7	Air-Cooled Condensers—130 to 2,225 MBh	105
Software Tools That Make Your Job Easier	7	Direct Drive Fluid Coolers—5 to 212 Tons	108
Smartphone Apps	7	Air-Cooled Chillers	112
Aftermarket and Parts Solutions	8	Air-Cooled Scroll Compressor Chillers—25 to 190 Tons	113
Service	9	Pathfinder® Air-Cooled Screw Compressor Chillers	
MicroTech® Integrated Systems	10	—170 to 550 Tons	126
Controls Integration	13	Water-Cooled Chillers	146
Self-Contained Air Conditioning Systems	15	Water-Cooled Scroll Compressor Chillers—30 to 200 Tons	147
Self-Contained Air Conditioning Systems		Water-Cooled Screw Compressor Chillers—130 to 190 Tons	153
—Type SWP and SWT	16	Magnitude® Magnetic Bearing Centrifugal Chillers	
Commercial Rooftop Systems	23	—100 to 700 Tons	156
Rebel™ Packaged Cooling and Heat Pump Units		Water-Cooled Centrifugal Compressor Water Chillers	
—3 to 12 Tons	23	—200 to 2,700 Tons	160
Maverick™ I Packaged Cooling and Heat Pump Units		Templifier Water Heaters	164
—3 to 25 Tons	31	Modular Central Plant	169
Maverick™ II Packaged Singlezone Cooling Units		Fan Coils	173
—15 to 75 Tons	38	Concealed Economy Ceiling Fan Coils—200 to 1,200 cfm	174
Applied Rooftop Systems	45	ThinLine™ Horizontal Fan Coils—200 to 1,200 cfm	176
RoofPak™ Packaged Singlezone Heating and Cooling Units		ThinLine™ Vertical Fan Coils—200 to 1,200 cfm	180
—15 to 140 Tons	45	HiLine™ Vertical Stacking Fan Coils—300 to 1,200 cfm	182
RoofPak™ Models RPE and RDE Singlezone		Large Capacity Fan Coils—600 to 3,000 cfm	184
Heating and Cooling Units—75 to 150 Tons	53	ThinLine™ Vertical Cabinet Unit Heaters	190
Coils	55	ThinLine™ Horizontal Cabinet Unit Heaters	192
Water Cooling or Heating, Evaporator and Steam		Steam/Hot Water Unit Heaters, Vertical and Horizontal	196
—Fin Types HI-F5, HI-F8 and E-F5	55	Unit Ventilators	198
Custom Air Handling Products	59	AAF®-HermanNelson® Unit Ventilators	199
Custom Air Handling Products—900 to 129,000 cfm	59	Two-Stage Self-Contained Unit Ventilators	
Commercial Outdoor Air Handling Products	61	—Models AZ and AE	201
Skyline™ Outdoor Air Handlers, 3 to 92 ft ²		Water Source Heat Pump Self-Contained Unit Ventilators	202
—900 to 65,000 cfm	62	PTAC/PTHP	209
RoofPak™ Model RDS and RAH Air Handlers		16" x 42" Applied Packaged Terminal Air Conditioners	
—4000 to 50,000 cfm	67	and Heat Pumps—7,400 to 16,800 Btuh	210
Commercial Indoor Air Handling Products	75	16" x 44" Model PDAE/PDHE Applied Packaged Terminal	
Destiny™ Air Handlers		Air Conditioners and Heat Pumps—7,400 to 16,800 Btuh	221
—2 to 30 ft ² Face Area, 600 to 15,000 cfm	76	Legacy Incremental® and Packaged Terminal Conditioners	
Vision™ Air Handlers		and Heat Pumps	225
—3 to 160 ft ² Face Area, 900 to 100,000 cfm	84	Water Source Heat Pumps	228
Fan Array for Vision™ Air Handlers	93	SmartSource™ Water Source Heat Pumps	229
		½ to 6 Ton Single Stage and 2 to 6 Ton	
		2-Stage High Efficiency	229
		SmartSource™ Inverter Water Source Heat Pumps	233
		Small Horizontal Ceiling-Mounted—1/2 to 6 Tons	237
		Large Horizontal Ceiling-Mounted—6 to 10 Tons	240
		Vertical Floor-Mounted—3/4 to 6 Tons	241
		Large Vertical Floor-Mounted—6 to 25 Tons	246
		Rooftop Outdoor Curb-Mounted—12 to 35 Tons	248
		Vertical Stack Water Source Heat Pumps—3/4 to 3 Tons	251
		Console In-Room—1/2 to 1 1/2 Tons	255
		Water to Water Floor-Mounted—3 to 35 Tons	258

Welcome to the Daikin 2013 All Products Catalog

Use this document as your quick reference to locate and understand the specifications, features and benefits of all Daikin heating, ventilation and air conditioning (HVAC) products, systems and services.

For the most current and detailed product information, or to locate your local Daikin representative, visit DaikinMcQuay.com or call 1-800-432-1342. You can also subscribe at DaikinMcQuay.com to receive e-mail notification of new product announcements, design tools, application information and engineering newsletters.



About Us

A World Leader In HVAC

Daikin Industries, a Fortune 1000 company is the largest air conditioning, heating, ventilating and refrigeration company in the world. Combining advanced technologies and R&D capabilities, Daikin is creating innovative products, systems and services that benefit the industry and the lives of our customers.

And with more than six million square feet of manufacturing space and 5,000 dedicated employees in 75 countries on six continents, Daikin is uniquely positioned to make sure our products and services are always within our customers' reach.



Daikin Industries World Headquarters, Osaka, Japan

Daikin Facilities North America



World Headquarters—
Minneapolis, Minnesota



Auburn, New York



Faribault, Minnesota



Owatonna, Minnesota



Phoenix, Arizona



Staunton, Virginia



San Luis Potosi, Mexico



Parts Warehouse—Dayton, Ohio

Asia



Shenzhen, China



Suzhou, China



Wuhan, China



Kuala Lumpur, Malaysia

Europe



Cecchina, Italy



Cramlington, United Kingdom

World Class Applied Development Center

The Daikin Applied Development Center supports product development, testing and verification of a full range of Daikin and Daikin commercial heating, ventilation, air conditioning and refrigeration (HVAC) systems for worldwide markets. The state-of-the-art center includes the latest technological advancements in the HVAC industry.



Applied Development Center—Interior

The Applied Development Center, located at Daikin's Minneapolis headquarters, allows the expertise of each company to be leveraged in a combined facility to accelerate the development of innovative, environmentally responsible products, systems and services that benefit the industry and our customers. It is also an exciting and concrete example of Daikin's commitment to growth in the commercial HVAC market in North America. Awarded LEED® Gold Certification.



Applied Development Center—Exterior

World Class Sustainability—ours and yours

In addition to the Applied Development Center, other Daikin facilities have been recognized for sustainability. The national Parts warehouse has been certified as an Energy Star® building by the U.S. EPA while the Chiller Engineering offices in the Staunton facility are certified LEED® Silver.

ISO 14001 Certified Facilities

Five facilities in North America are certified to the ISO 14001 environmental management system standard aimed at continuous environmental improvement. Daikin is aggressively pursuing ISO 14001 certification in all its facilities.

High Performance Systems for High Performance Buildings

Daikin offers a variety of design tools to help system designers achieve their goals of efficient, sustainable facilities. Because many of our sales and service representatives are certified as LEED APs, we can help system designers meet their own sustainability goals. As a result, Daikin systems are a popular choice for high performance buildings.



Photo © 2012 Bruce Damonte

The San Francisco Public Utilities Commission headquarters has been certified as LEED® Platinum and called "the greenest office building in America". Two Daikin Magnitude® magnetic bearing chillers are at the heart of the high efficiency HVAC system in the building.

Daikin Solutions Plaza

Located across from Manhattan, the Daikin Solutions Plaza is a unique showcase where the latest innovations from Daikin and Daikin McQuay are available for viewing hands-on. Top clients from all over the world visit the Solutions Plaza to view the interactive, full size displays that bring our HVAC technology to life.

The Solutions Plaza is also an education site hosting opportunities to learn the latest industry trends and earn continuing education credits. Daikin product experts can be available for application and design discussions either in person or via video conferencing.



Also located at the Solutions Plaza facility is Daikin New York. System experts in this office consult with building owners, architects, engineers and contractors to select and design comfortable, efficient solutions to their biggest challenges in the New York City, Long Island, and Westchester markets.



Live video connections with the Daikin chiller manufacturing facility in Staunton, Virginia, allow Solutions Plaza visitors to witness the testing of their chillers at specific operating conditions in real time.

Daikin Learning Institute

The Daikin Learning institute benefits the facility and HVAC industries in multiple ways. Our goal is to be the pre-eminent source of HVAC system knowledge and share that knowledge with HVAC professionals, technicians, building operators and our sales representatives.

System training and professional development courses help ensure that Daikin representatives have the design and application expertise to recommend system solutions for all facility types. They also learn industry trends and best practices to become valuable members of a project team.

Technical training for owner operators and service contractors helps them get the most benefits from their Daikin HVAC equipment. Training courses provide both classroom and hands-on learning and are eligible for continuing education credits. Eleven separate courses are held multiple times each year for the convenience of attendees, and new courses are continually added. For large groups, we will come to your site and customize a training session specifically for your application. To see the complete schedule of classes and to enroll online, visit the Training page on DaikinApplied.com.



Training classroom at the Daikin Solutions Plaza



Daikin has been approved as an Authorized Provider by the International Association for Continuing Education and Training (IACET) 1760 Old Meadow Road, Suite 500, McLean, VA 22102, (703) 506-3275.

Software Tools That Make Your Job Easier

Designing and specifying the ideal HVAC system can be a time- and cost-intensive process. That's why we developed these user-friendly Windows® - based software programs; Daikin Tools™, EnergyAnalyzer™ II, and Acoustic Analyzer™. For more information about Daikin McQuay software for engineers, contact your local Daikin McQuay sales representative.

Daikin Tools for Engineers—This web-enabled selection software program makes it easy to choose from a variety of sizes and product options to design the HVAC system that fits your requirements. Daikin Tools for Engineers is available from your local Daikin representative.



Building Information Modeling (BIM)—Daikin and Daikin have developed the most comprehensive library of manufacturer-created Autodesk® Revit® object models and content for our HVAC products. Our library of object models and content continues to grow and can be found at DaikinApplied.com on the Revit Files page or on the Autodesk Seek website.



Energy Analyzer II—A user friendly front end to EnergyPlus™, the premier energy simulation program developed by Lawrence Berkley National Laboratory for the U.S. Department of Energy. This new web-based energy analysis program provides an easy-to-use method of estimating energy consumption, operating costs and life cycle analysis between two HVAC systems so the best financial decision can be made.

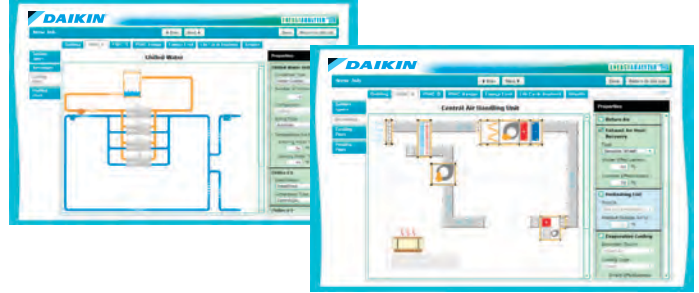

Acoustic Analyzer—Lets you estimate the sound of HVAC equipment in a space or at the property line using your design conditions. This software can help you determine if your equipment selection will meet specifications. View a demonstration of this software at DaikinApplied.com under the Design Tools link.

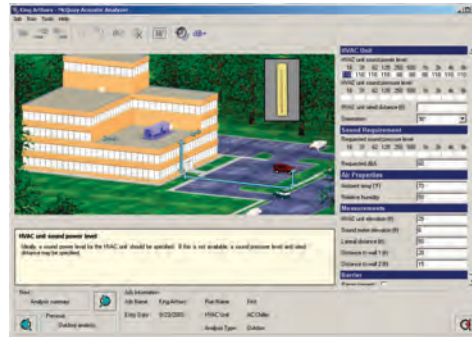

Design Solutions for You

Smartphone Apps

Daikin offers free smartphone apps to make selection easier than ever. Scan the QR codes below to bookmark these apps or use the URLs provided.

Vision® Air Handler Quick Select App identifies which unit size meets your cfm range, coil sq.ft. area, cabinet dimensions and option availability for meeting preliminary job requirements. <http://vision.launchqcr.com>



Stock Availability App helps you find a variety of Daikin equipment that is available in-stock for immediate or quick ship including chillers, commercial rooftop units, condensing units and terminal systems. <http://apps.Daikincom/stockapp/>



Aftermarket and Parts Solutions

Whether you are installing, maintaining or servicing an HVAC system, Daikin offers a complete line of quality parts and supplies to keep your system operating reliably and at peak efficiency. Our 156,000 square foot Parts Warehouse is stocked with an extensive variety of OEM parts ready when you need them.

The Parts Warehouse staff is committed to customer service. They have achieved world-class order handling and shipping rates that get the right parts to you fast.

- 98.5 % same day shipping
- 100% next day air shipping

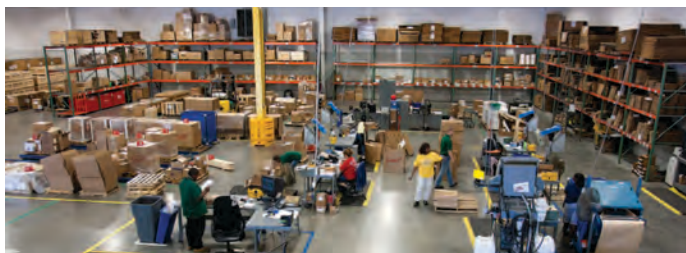

The Daikin Parts Warehouse provides world-class customer service to minimize HVAC system downtime.

The Parts Warehouse is also a prime example of Daikin's commitment to environmental responsibility with multiple national certifications:

- Energy Star® building certified by the U.S. EPA signifying that it performs in the top 25% of similar facilities nationwide for energy efficiency
- ISO 14001 certified for effectively implementing an environmental management system

Local Inventory, Local Expertise

Daikin has an extensive network of Parts distributors throughout North America. These Parts distributors have local inventory of critical parts, as well as a parts store for customers to make walk-in purchases. They have the equipment experience and knowledge to provide parts on the spot. To locate a Daikin parts distributor near you, visit DaikinApplied.com.

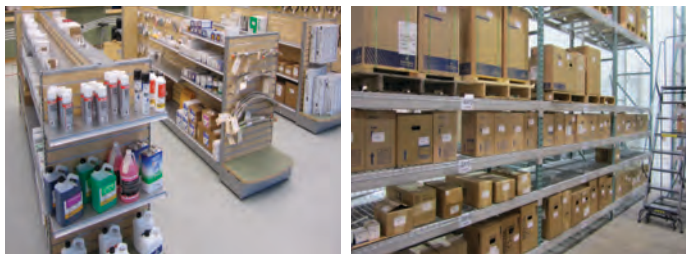

Local Daikin Parts stores with their in-stock inventory are one-stop shops for HVAC parts and supplies.

OEM Parts for Reliability and Performance

Because they are designed and/or specified by the original equipment manufacturer (OEM), Daikin quality parts can enhance the performance of your HVAC system

and increase the operating life of your investment. Overall maintenance costs are reduced, improving your bottom line. Daikin offers a variety of OEM parts.

- Daikin products
- AAF® HVAC products
- ClimateControl® HVAC products
- AAF®-HermanNelson® classroom unit ventilators
- Remington® air conditioning products
- Singer® packaged terminal air conditioners (PTAC)
- Westinghouse® commercial air conditioning products
- Copeland® compressors

Equipment Upgrades and Modernizations

Optimize the performance and energy efficiency of your existing equipment with field installed components from Daikin.

- Variable frequency drives (VFD)
- Digital and analog controls
- High efficiency motors
- Remote user interface panels
- A complete line of compressors
- Electrical bearing protection for motors with VFDs
- Coils
- Magnetic bearing chiller modernization kits for centrifugal chillers
- Replacement parts for water source heat pumps and PTACs
- Ancillary contractor supplies

Comprehensive Parts Catalog

For a list of the most commonly required Daikin parts, use our Parts and Aftermarket Products Catalog. You can search 15 categories and more than 4,200 products to easily find the parts you need. Use the online version on the Parts and Upgrades page of DaikinApplied.com. Or visit a Daikin Parts Store near you to receive a printed copy.

Table of Contents	
Aftermarket Products	9-13
Controls	14-21
Coils	22-27
Compressors	28-73
Controls (continued)	73-91
Drive Components	92-111
Electronics	112-126
Fans	128-142
Hardware	144-151
Inductors	152-157
Refrigerants	158-163
Refrigeration	164-203
Maintenance Equipment	204-208
Tools	240-251

Daikin Service Solutions

Capital Budgeting

Enhance your business with strategic HVAC asset planning to offset future energy costs and aging infrastructure.

Planned Maintenance

Protect your valuable assets with a results-oriented maintenance strategy designed to meet your specific business requirements and objectives.

Emergency Repairs

We offer emergency repair services 24 hours, 7 days a week on Daikin and other HVAC equipment.

Equipment Upgrades

Our technicians can optimize your older chiller by adding digital controls and variable frequency drives to improve its energy efficiency.

Equipment Replacements

If you're looking to replace equipment, we can do fully engineered, turnkey equipment replacements. Newer, more efficient equipment can pay for itself in a short time based on energy savings alone.

Training for Maintenance Staff

Reduce your maintenance costs by learning how to perform routine maintenance and troubleshooting tasks. The Daikin Learning Institute offers both classroom service training and on-site training.



Complete Building HVAC Service

Our account representatives and factory trained technicians can provide quick response and proactive solutions for any building requirement.



We offer complete building services for all brands including Daikin and all types of HVAC systems:

- Centrifugal chillers, including magnetic bearing
- Screw chillers
- Scroll chillers
- Absorption chillers
- Cooling towers
- Boilers
- Packaged rooftop units
- Air handling equipment
- Exhaust/make-up air systems
- Pumping systems
- Water treatment
- Split DX systems
- Building controls
- And more

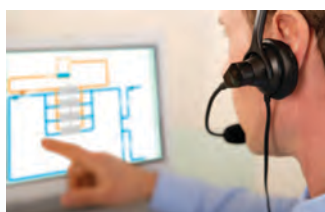

D-Net[®] Performance Services for Quicker Response and Enhanced Support

Daikin's maintenance and service offerings now include enhanced options for D-Net[®]

Performance Services capabilities. As an innovative, web-based offering, D-Net facilitates remote diagnostics, service, and performance monitoring. This capability enables McQuay Service to flag maintenance proactively, evaluate and/or resolve issues quickly, and provide regular, documented communication to facilitate not only service and maintenance decisions, but also decisions about equipment upgrades or replacement.

MicroTech® Integrated Systems

Daikin MicroTech Integrated Systems provide the ultimate in efficiency and comfort by seamlessly combining advanced controls and innovative, high performance HVAC equipment. Components are pre-programmed at the factory so that the system is easy to install, start-up and commission at the job site.

This system is ideal for buildings that want energy efficiency, ventilation air and superior control.

- Schools
- Medical and dental offices
- Retail
- Small to mid-sized offices
- Multi-unit residential facilities

Smart Solutions for Smart Savings

For Contractors

- Faster installation and wiring
- Faster commissioning and system start-up because job-specific data is pre-loaded at the factory

For Building Owners and Managers

- Easy access to system status and control with the web browser-based interface
- Better system efficiency and performance since all the components work seamlessly together
- More affordable than a building automation system but with much the same flexibility

Putting System Information to Work for You



Save Time at the Job Site

- Faster Installation*
- Faster System Start-up*
- Faster Commissioning*

MicroTech® Integrated System for VAV Applications

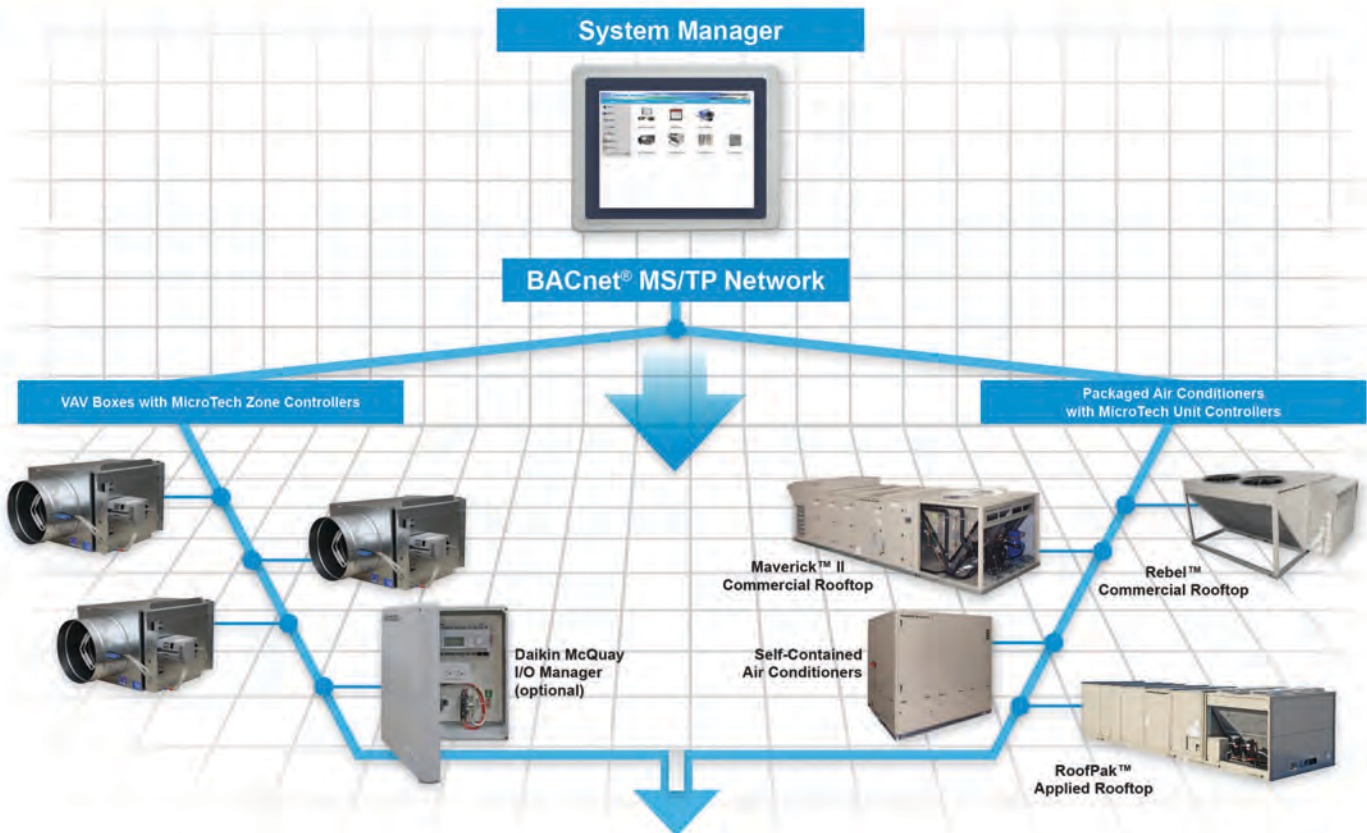

Connect up to 100 Total Devices in a System

MicroTech
Integrated Systems

Powerful and Affordable

The MicroTech Integrated System has many of the same control and monitoring functions of a building automation system but at a fraction of the cost.

- **Scheduling** – use default occupancy schedule or enter custom seven-day schedules and holidays so equipment runs only when needed.
- **Remote Monitoring** – connect to local network to view current status from any computer, smartphone or tablet.
- **Alarm Management** – receive notification when an alarm occurs via email or text message.
- **Graphical Trending** – analyze operation trends proactively.
- **User Security** – five levels of access.
- **Ancillary control** - for custom job-specific control sequences or alarms.



With the browser based interface, you can remotely access the system using any device with a web browser – laptop, smartphone, or tablet.

For all MicroTech Integrated Systems

Daikin's 100% outdoor air (OA) packaged air conditioners offer a complete range of sizes and features to ensure excellent indoor air quality without compromising energy efficiency.

- Rebel™ rooftop unit, 3 to 15 tons
- Maverick™ II commercial rooftop, 15 to 75 tons
- RoofPak™ applied rooftop, 15 to 140 tons
- Self-Contained system, 12 to 130 tons

MicroTech® Integrated System for Water Source Heat Pump Applications

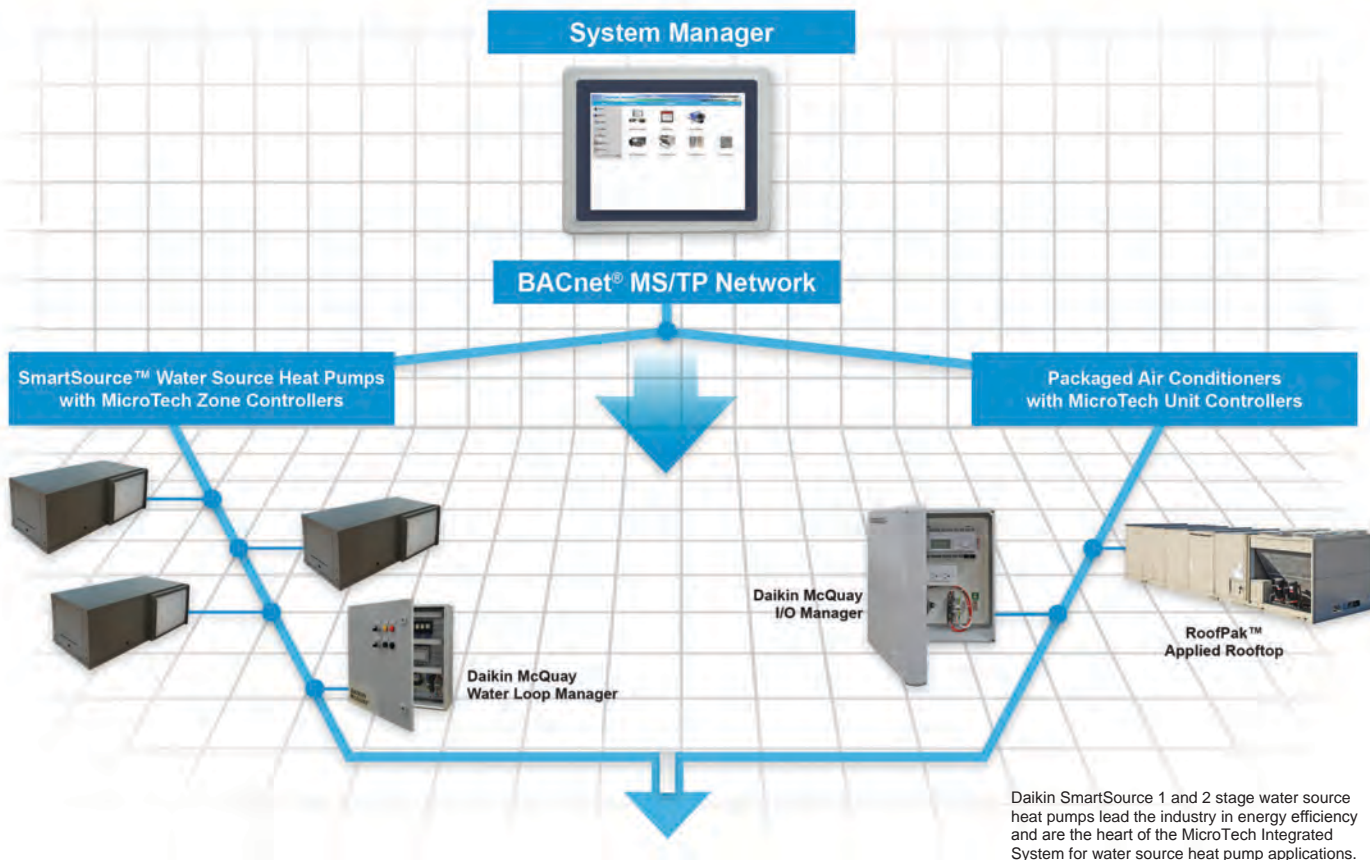

Daikin SmartSource 1 and 2 stage water source heat pumps lead the industry in energy efficiency and are the heart of the MicroTech Integrated System for water source heat pump applications. See page 229 for more information.

Connect up to 100 Total Devices in a System

Combining Daikin 100% Outdoor Air Equipment with a Daikin VRV System

The high performance of Daikin 100% outdoor air rooftop units can be seamlessly combined with the absolute comfort of the Daikin variable refrigerant volume (VRV) system.

The factory-installed communications gateway allows any packaged Daikin MicroTech® III 100% outside air unit to be seamlessly integrated into a Daikin VRV system through the Daikin intelligent Touch Controller. This gateway provides an easy to wire, simple to configure system that provides more sophisticated control than a hardwire interlock.

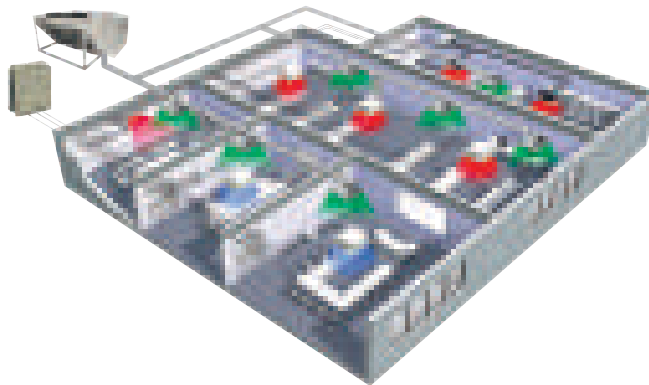

MicroTech Integrated System Control Components

System Manager

The operator can make schedule changes, adjust setpoints and manage alarms to ensure the comfort of the occupants through the browser-based color touch screen panel. This unit is compatible with Daikin rooftops, self-contained units and water source heat pumps using MicroTech III unit controls.



Input/Output (I/O) Manager

Auxiliary equipment like exhaust fans can be integrated into a MicroTech Integrated System. This panel can also be used for custom job-specific control sequences or alarms.



Water Loop Specific Components

Loop Water Manager

Water source heat pump systems use the Loop Water Manager to optimize pumps, cooling towers, and boilers.



Variable Air Volume (VAV) Specific Components

BACnet® VAV Actuator

The BACnet VAV Actuator provides high performance direct digital control (DDC) of pressure-independent, VAV zone-level routines.



Room Temperature Sensor

These room sensors are for use with Daikin BACnet VAV Actuator controllers. The modern design compliments any décor and allows Timed Override by building occupants.



Terminal Units

Single duct terminal units offer capacities from 80 to 8,000 cfm. Series and parallel fan configurations are available. Hot water or electric reheat are available on all models.



Flexibility and Simplicity

Our Open Choices™ controls feature gives you the flexibility to use standard open communication protocols to integrate your Daikin HVAC equipment with your choice of building automation system – without expensive gateway panels.

We've done the work to make integration simple and easy for you.

- Testing with building automation system (BAS) suppliers
- Compliance with BACnet®, Modbus® and LONtALK® protocols

The Open Choices feature is available on the entire family of MicroTech® unit controllers as shown in the table below. Regardless of the type of Daikin equipment that you have, our controllers offer:

- Optional factory-programmed and tested communication modules that plug into the controllers
- LONMARK® certified and BACnet conformance tested
- Ability to upgrade communication modules to migrate as your BAS is upgraded or expanded
- Reduced start-up and commissioning time
- Easy to learn and easy to use operator panels

For the specific control strategies and monitoring capabilities of each equipment type, refer to the individual product sections in this catalog or visit the product pages of DaikinApplied.com

Open Choices™ Feature for BAS Integration

Open Choice Options for Integrating Daikin Unit Controllers into a BAS

Unit	Controller	LONMARK Certified	BACnet MS/TP	BACnet IP	BACnet Ethernet	Modbus
Applied Rooftop/Self-Contained	MicroTech III	3.4	Yes	Yes	No	No
Maverick II™ Rooftop	MicroTech III	3.4	Yes	Yes	No	No
Maverick I™ Rooftop	Maverick I	3.4	Yes	Yes	Yes	No
Rebel™ Rooftop	MicroTech III	3.4	Yes	Yes	No	No
Water Source Heat Pumps	MicroTech III	3.4	Yes	No	No	No
Pathfinder™ (AWS)/AGZD Chillers	MicroTech III	3.4	Yes	Yes	No	Yes
Magnitude® (WME) Chiller	MicroTech E	3.4	Yes	Yes	Yes	Yes
Chiller*	MicroTech II	3.3	Yes	Yes	Yes	Yes
Unit Ventilator	MicroTech II	3.3	Yes	No	No	No
Fan Coil	MicroTech III	3.4	Yes	No	No	No

*MicroTech II available for centrifugal, screw, and scroll unit controllers (models WSC, WDC, TSC, WMC, WCC, ACZ, WGZ, AGS, WGS, TGZ)

This page intentionally left blank.

Self-Contained Air Conditioning Systems

Self-Contained Air Conditioner Product Summary Chart

Model:

SWP

Small
Cabinet Size

Small/Tall
Cabinet Size

Medium
Cabinet Size

Large
Cabinet Size

Large/Tall
Cabinet Size

Model:

SWT

Small
Cabinet Size

Medium
Cabinet Size

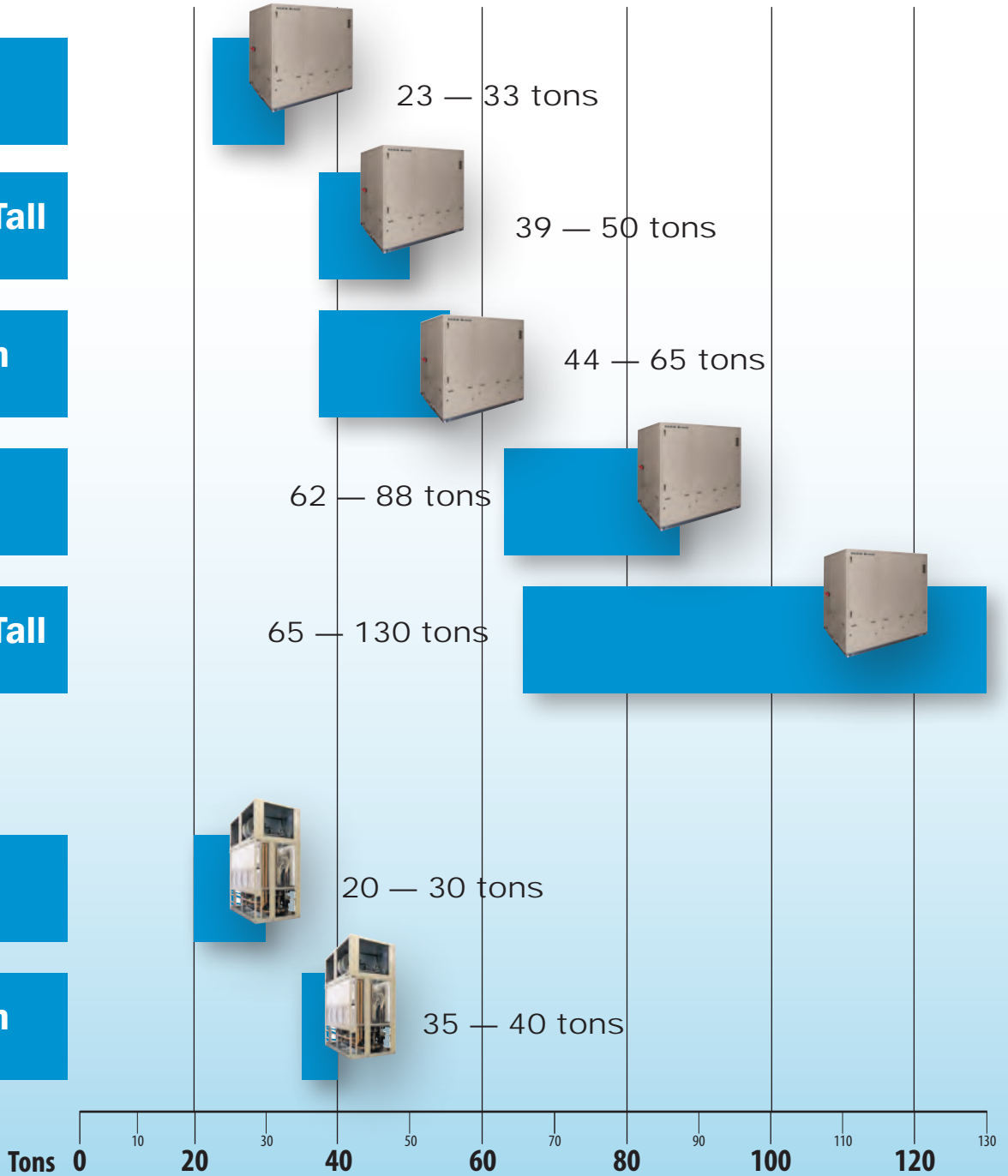

Self-Contained Air Conditioning Systems—Type SWP and SWT

- Pre-engineered flexibility to design systems without compromise
- Low installation and operating costs
- Plenum fans allow quieter operation
- Modular construction from 20 to 130 tons
- Controls flexibility—MicroTech® III controls with our Open Choices™ feature for easy integration with the BAS of your choice
- R-410A refrigerant allows higher efficiency (SWP only)

For more detail, refer to Catalogs 860 and 865.

For the most current information, refer to DaikinApplied.com.



Model SWP—20 to 130 tons

Performance complies with ASHRAE Standard 90.1-2010

- Many selections surpass a 14 EER
- Water and airside economizer capability
- Fan flexibility to comply with bhp/cfm
- Variable Frequency Drive (VFD) fan control to satisfy VAV requirements

Model SWT—ideal for retrofit and replacement

- Three separate sections can each negotiate 3 foot framed doorways - refrigeration system remains intact
- Integral waterside economizer
- Lower installation costs



Model SWT— 20 to 40 tons



Self-Contained Air Conditioning Systems Features and Options



Up to six row copper tube, aluminum fin evaporator coils

- Provide excellent full- and part-load temperature and humidity control
- Effectively handle lower discharge air temperature designs that can reduce first cost and operating costs
- Optional stainless steel drain pan and coil casing



Serviceable design

- Hinged access doors
- Reduces maintenance and service expense
- Easily accessed MicroTech III and VFD controls with user-friendly interfaces
- Cleanable condensers and economizer coils

Rugged cabinet enclosure

- Rigid thermally efficient (R-13) injected foam panels are strong and light weight (SWP only)
- Painted finish
- Promotes longer unit life
- Leakage of only 0.5 cfm/ft² at 5" cabinet pressure (typically less than 1%)

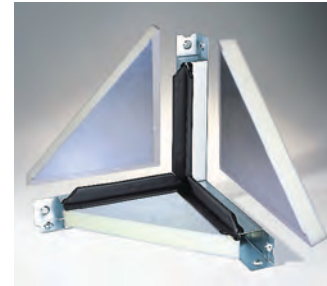

Gasketed frame channel (Model SWP only)

- Eliminates metal-to-metal contact between paneling and framework
- Minimizes cabinet condensate and corrosion
- Facilitates top and side component removal
- Promotes long life



Water-cooled condenser

- Simple, mechanically cleanable construction
- Provides high performance with enhanced tubing

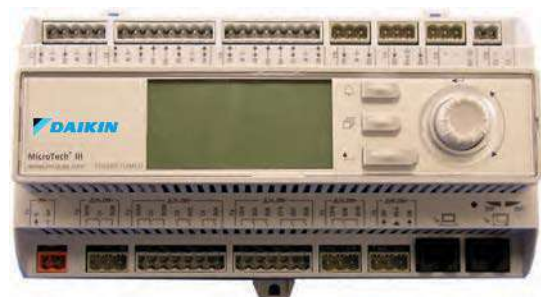

MicroTech® III control system

- Open Choices™ feature provides easy integration into the BAS of your choice
- LONWORKS® or BACnet® communication option
- Industry leading user interface
- Factory installed and tested for faster, lower cost, field commissioning

Self-Contained Air Conditioning System Model SWP—20 to 130 Tons

1 Blank sections

- Available to mount air blenders, carbon or charcoal filters, sound attenuators or other specialty equipment
- Allow customization for maximum system performance and efficiency
- Can reduce design and installation costs

2 Airfoil plenum fans

- SWSI fans more energy efficient and quieter than forward curved fans
- Premium high efficiency open, drip-proof standard motors and TEFC motors, an available option
- Seismic control restrained spring isolators are available
- Aerodynamically designed fan also available with 12 blades for even lower sound levels

3 Coils

- High efficiency enhanced corrugated fin design
- High coil performance and reduced static pressure losses
- Interlaced and/or row split circuiting to keep full face of the coil active and to eliminate air temperature stratification and optimum part load performance

4 Durable construction

- Pre-painted or G90 galvanized steel exterior cabinet panels
- Standard foam injected panels with R-13 insulation provide superior rigid double wall construction and minimizes air leakage
- For better acoustics, 2", 1.5# density R-8 fiberglass insulation is an available option for fan and plenum sections
- Double-sloped drain pans help eliminate standing stagnant water

5 Scroll compressor(s)

- Durable and reliable multiple compressors
- Lower operating cost with High EERs
- Customize selections to match specific application
- Mounted on resilient rubber isolation for smooth and quiet operation

6 Access panels and doors

- All panels and access doors are sealed with permanently applied bulb-type gasket
- Access doors are flush mounted to cabinetry, with hinges, latch and handle assembly



Self-Contained Air Conditioning Systems Features and Options

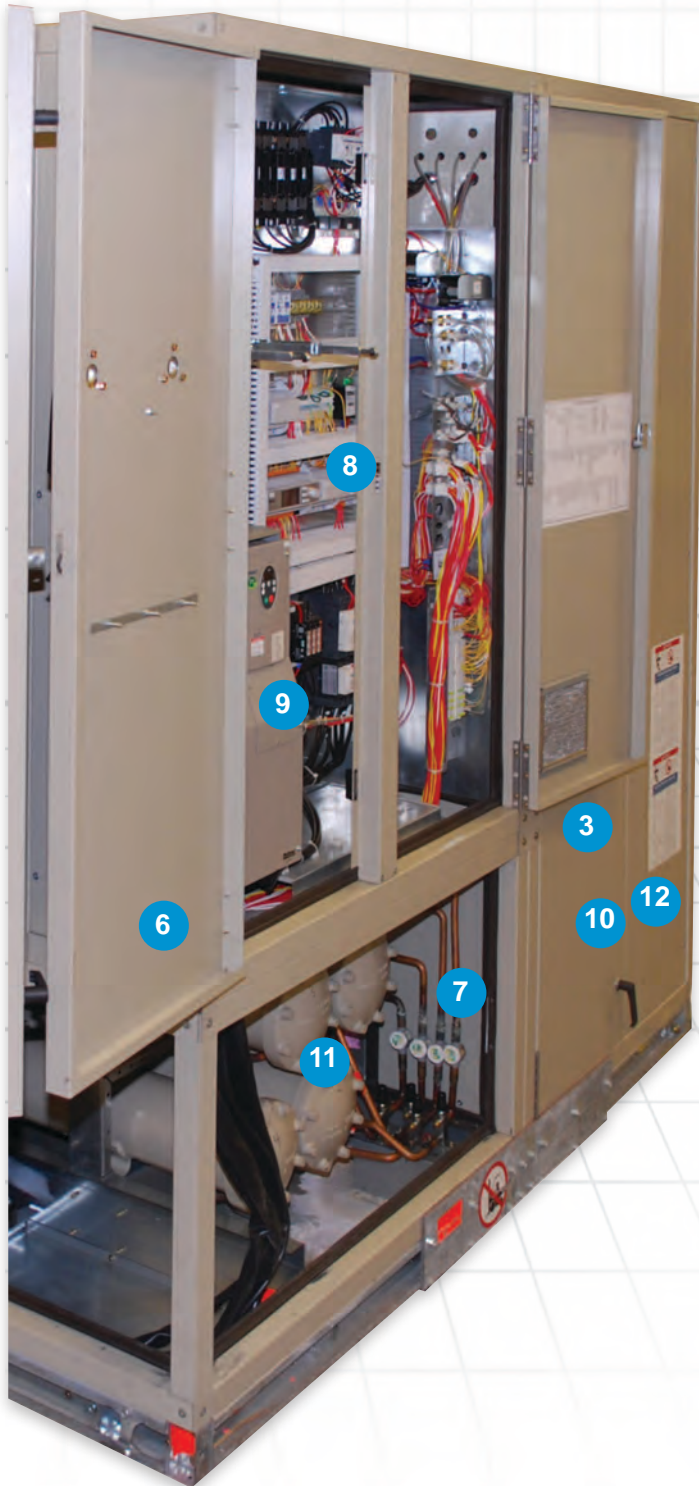

7 Refrigerant circuits

- Suction and discharge service valves to isolate each compressor, as an available option
- Hot gas bypass on units with two refrigerant circuits, as an available option

8 MicroTech® III control system

- Factory-installed and tested to help minimize costly field commissioning
- Open Choices™ feature for easy integration into the BAS of your choice using open, standard protocols such as BACnet® or LONTALK®
- Easily accessed for system diagnostics and adjustments via a keypad/display on unit
- Optional remote keypad and display that is identical to the unit-mounted user interface

9 Factory-mounted variable frequency drives

- Controlling fan motor speed can lower fan operating costs and sound levels
- All VFD selections are plenum rated
- Optional manually activated bypass contactor to allow system operation in the event of drive service

10 Economizer options

- Waterside economizer effectively uses low cooling tower water temperatures to offload compressor operation
- An airside economizer control package is available for controlling field installed mixing dampers capable of 100% outside airflow

11 Shell and tube condensers

- Carbon-steel shell and tube condenser, non-ferrous water channels and enhanced tubing for high performance
- Integral sub-cooling circuit is provided as standard to maximize efficiency
- Mechanically cleanable condenser and water piping is rated for standard 300 psig waterside working pressure and 450 psig is an available option
- Two-way valve for head pressure control is available for low condenser water temperatures without waterside economizer coil

12 Multiple filter options

- 2" 30% (MERV7) and 75% (MERV13) filters
- 4" 30% (MERV8), 65% (MERV11), 75% (MERV13) and 85% (MERV14) longer lasting filters available
- 4" primary filters also available with 2" or 4" with pre-filter

Self-Contained Air Conditioning Systems

Physical Data—SWP

Tons	Cabinet Size	Compressor Per Circuit	Max Fan Diameter (in.)	Cabinet Height (in.)	Cabinet Width (in.)	Cabinet Depth (in.)	DX Area (sq.ft.)
023	Small	6.0 / 15.0	24.5	80	84	80	17.2/25.2
028		10.0 / 15.0	24.5	80	84	80	17.2/25.2
033		15.0 / 15.0	24.5	80	84	80	17.2/25.2
039	Small/Tall	10.0 / 10.0 / 15.0	27.0	84	84	80	25.2/29.8
044		10.0 / 15.0 / 15.0	27.0	84	84	80	25.2/29.8
050		15.0 / 15.0 / 15.0	27.0	84	84	80	29.8
044	Medium	10.0 / 15.0 / 15.0	36.5	96	102	88	40.8
050		15.0 / 15.0 / 15.0	36.5	96	102	88	40.8/45.2
056		13.0 / 13.0 / 13.0 / 13.0	36.5	96	102	88	40.8/45.2
062		13.0 / 13.0 / 15.0 / 15.0	36.5	96	102	88	40.8/45.2
065		15.0 / 15.0 / 15.0 / 15.0	36.5	96	102	88	40.8/45.2
062	Large	13.0 / 13.0 / 15.0 / 15.0	36.5	96	126	98	52.5
073		10.0 / 10.0 / 10.0 / 10.0 / 13.0 / 13.0	36.5	96	126	98	52.5
080		10.0 / 10.0 / 13.0 / 13.0 / 13.0 / 13.0	36.5	96	126	98	52.5
088		13.0 / 13.0 / 13.0 / 13.0 / 13.0 / 13.0	36.5	96	126	98	52.5
065	Large/Tall	15.0 / 15.0 / 15.0 / 15.0	44.0	112	126	98	60.9
073		10.0 / 10.0 / 10.0 / 10.0 / 13.0 / 13.0	44.0	112	126	98	60.9
080		10.0 / 10.0 / 13.0 / 13.0 / 13.0 / 13.0	44.0	112	126	98	60.9
088		13.0 / 13.0 / 13.0 / 13.0 / 13.0 / 13.0	44.0	112	126	98	60.9
099		15.0 / 15.0 / 15.0 / 15.0 / 15.0 / 15.0	44.0	112	126	98	60.9/71.3
105		13.0 / 13.0 / 13.0 / 13.0 / 13.0 / 13.0 / 13.0 / 13.0	44.0	112	126	106	60.9/71.3
120		13.0 / 13.0 / 13.0 / 13.0 / 15.0 / 15.0 / 15.0 / 15.0	44.0	112	126	106	60.9/71.3
130	15.0 / 15.0 / 15.0 / 15.0 / 15.0 / 15.0 / 15.0 / 15.0	44.0	112	126	106	60.9/71.3	

- Available in Small/Tall or Medium cabinet sizes
- Available in Medium, Large or Large/Tall cabinet sizes
- Available in Large or Large/Tall cabinet sizes

Self-Contained Air Conditioning Systems

Physical Data—SWT

Data	SWT Model Size				
	018C	023C	028C	035C	040C
Dimensions					
Depth,	52.00	52.00	52.00	52.00	52.00
Length ^{1, 2}	84.00	84.00	84.00	100.00	100.00
Height ^{1, 2}	122.75	112.75	112.75	112.75	112.75
Compressor					
Quantity	4	4	4	4	4
Evaporator Coil					
Face area (ft ²)	11.8	15.3	18.9	23.3	26.3
Rows	4, 6	4, 6	4, 6	4, 6	4, 6
FPI	12	12	12	12	12
Waterside Economizer Coil					
Face area (ft ²)	11.8	15.3	18.9	23.3	26.3
Rows	4	4	4	4	4
FPI	12	12	12	12	12
Maximum working pressure (psig)	400	400	400	400	400
Hot Water Heating Coil					
Face area (ft ²)	9.3	12.8	16.3	20.2	23.8
Rows	1, 2	1, 2	1, 2	1, 2	1, 2
FPI	12	12	12	12	12
Electric Heat					
kW	34	34	34	34	34
Filters					
(Quantity) size 4" depth filter	(3) 20 × 20 (2) 25 × 20 (4) 16 × 25	(3) 20 × 20 (2) 25 × 20 (4) 16 × 25	(3) 20 × 20 (2) 25 × 20 (4) 16 × 25	(5) 20 × 20 (5) 25 × 20	(5) 20 × 20 (5) 25 × 20
Evaporator Fan³					
Quantity	1	1	1	2	2
Size	15	18	18	15	15
Minimum horsepower	5	7.5	10	10	15
Maximum horsepower	10	15	20	20	25
Minimum design cfm, CV	2950	3825	4725	5825	6575
Minimum design cfm, VAV	4720	6120	7560	9320	10,520
Maximum design cfm	7080	9180	11,340	13,980	15,780
Condensers					
Waterside working pressure (psig)	400	400	400	400	400
Minimum entering temperature (°F) mechanical cooling	55	55	55	55	55
Minimum gpm	25	41	53	66	69
Maximum gpm	88	108	125	159	166

1. Dimensions do not include lifting lugs, handle, latch, or fastener extensions

2. For shipping dimensions add 4" (102mm) to depth, 8" (204mm) to length, and 4" (102mm) to height

3. Standard fan TSP limit is 5.5 inches of water. Consult your local Daikin Sales Representative for applications beyond this range

Rooftop System Product Summary Chart

Model:

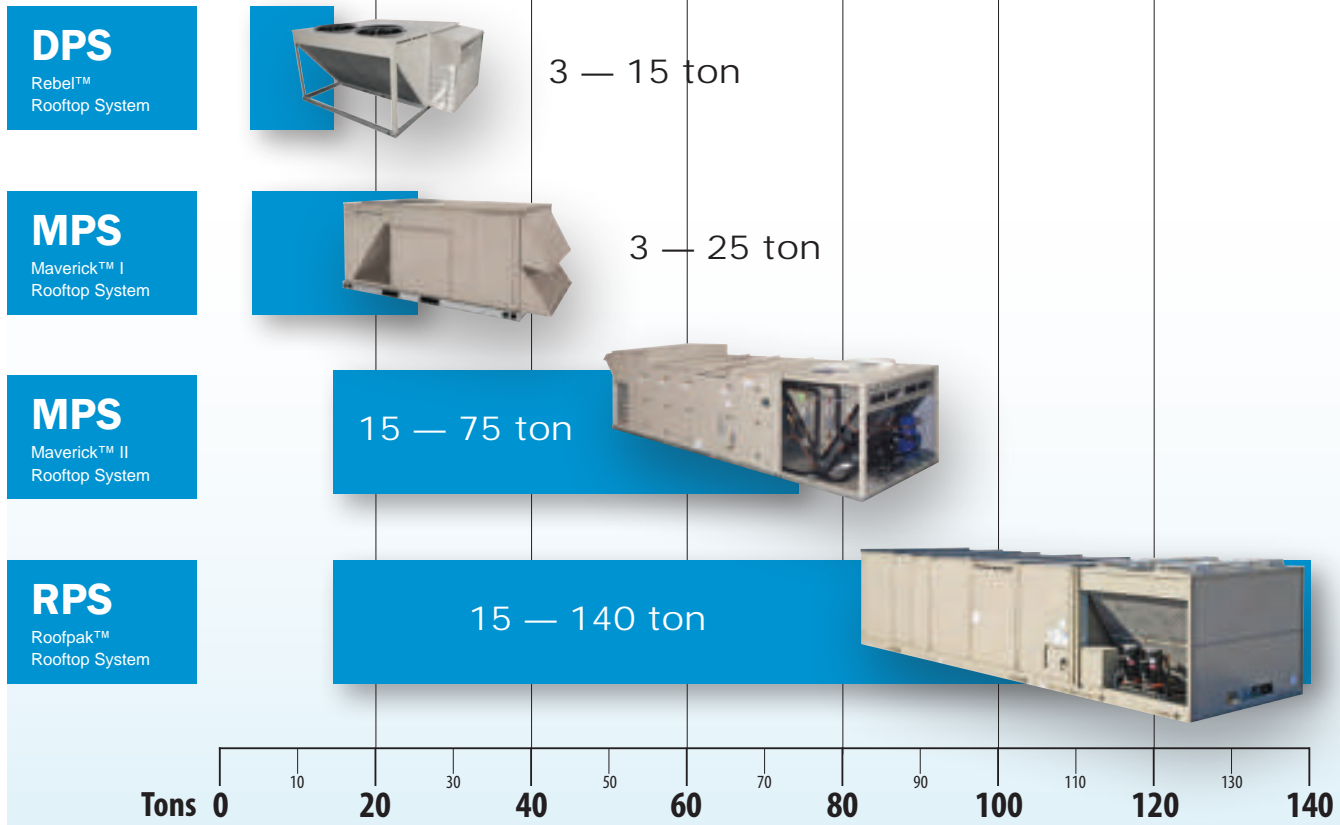

Rebel, Maverick II and RoofPak rooftop systems are ideal for 100% make up air applications. Units can be equipped with 100° temperature-rise furnaces for cold-weather climates and modulating hot gas reheat to increase occupant comfort and avoid over-cooling.

Rebel™ Packaged Cooling and Heat Pump Units—3 to 15 Tons

- Optional Energy Recovery Wheel
- Cooling or heat pump units, VAV down to 3 tons
- Variable speed heat pump with hybrid (gas, electric, hot water) heat options
- IEERs exceed ASHRAE 90.1-2010 by up to 80%
- Variable speed inverter scroll compressor for capacity control
- Double wall construction with foam injected R7 insulation
- Gas heat options with 10:1 modulating furnaces
- Electric heat options with SCR control
- Economizers with 100% design airflow exhaust
- Variable speed ECM motors on all fans
- Ultra-quiet Daikin condenser fans
- Condenser fan with head pressure control from 0°F~115°F ambient
- Non-ozone depleting R-410A refrigerant

For more detail, refer to Catalog 256.

For the most current information, refer to DaikinApplied.com.

Now with
Energy
Recovery
Wheel!



Model DPS—3 to 6 tons

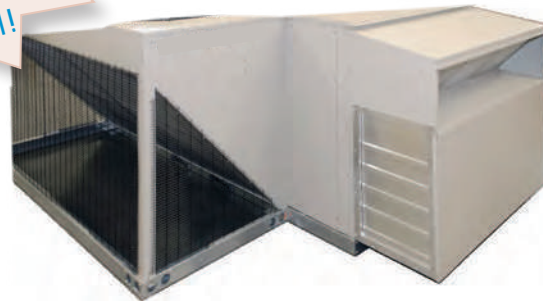

Model DPS—7 to 12 tons



Rebel™ Packaged Cooling and Heat Pump Units—3 to 6 Tons

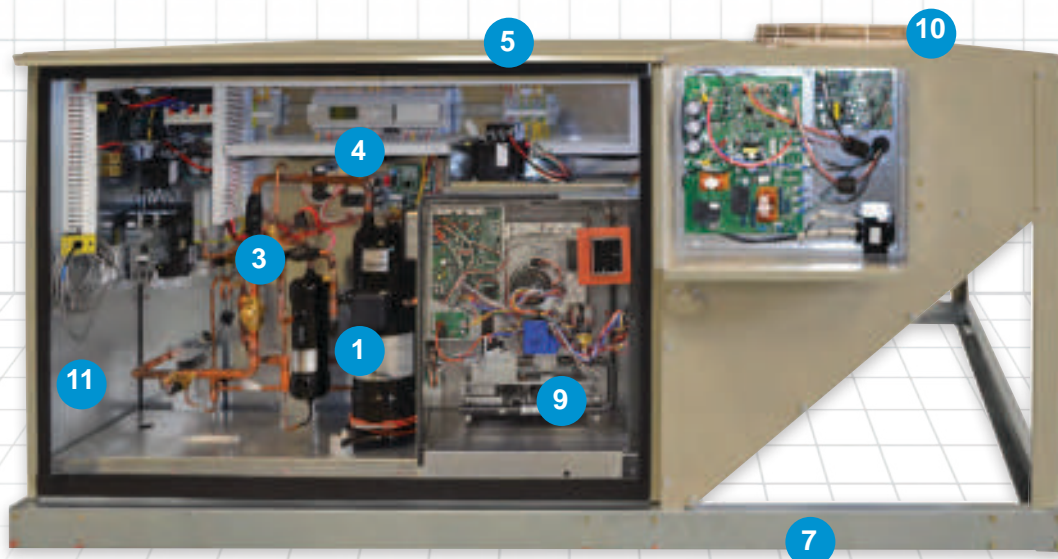

1 Variable speed Daikin inverter compressor

- Modulating capacity allows for optimum comfort control
- Best part-load efficiency in the industry
- Dependable and quiet operation
- Superior discharge air temperature control

2 Variable speed Daikin heat pump

- More economic than gas heat during winter
- Hybrid backup heat options for extreme cold weather and defrost operation
- Modulating capacity delivers the industry's best heat pump control

3 Electronic expansion valves

- Optimum control of superheat
- Protects compressor from liquid refrigerant
- Increases efficiency by safely lowering head pressure

4 MicroTech® III unit controller

- Open Choices™ feature provides interoperability with BACnet®, Daikin D3 and LONWORKS® communication options for easy integration with building automation systems
- Unit diagnostics for easy serviceability
- Outdoor air and humidity control logic maintains minimum fresh air intake and optimum humidity levels

5 Seamless top panel

- Seamless construction prohibits leaks

6 Hinged access doors

- ¼–turn latch door provide easy access to system components for maintenance and service

7 Full-perimeter, forkable base rail

- Allows easy maneuvering and installation

8 Variable speed ECM motors on all fans

- Greatly increases system reliability and efficiency eliminates belts and bearing setscrews
- Saves energy at light load
- Super-efficient magnetic rotor
- Built-in inverter eliminates control panel heat

9 Hybrid backup heat options

- Gas furnace with turndowns as high as 10:1
- Electric heat option with SCR for precise temperature control
- Hot water heat

Rebel Packaged Cooling and Heat Pump Units Features and Options

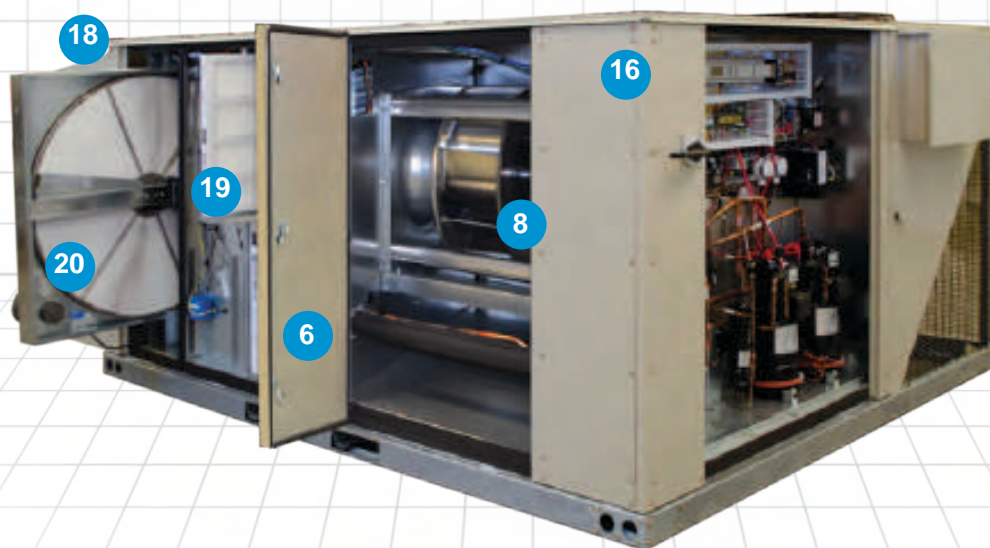

10 Ultra-quiet Daikin condenser fans

- One-piece composite blade design for noiseless operation
- UV and corrosion resistant
- Variable speed ECM motors provide tremendous energy savings at lower ambient

11 Double-wall foam cabinet

- No exposed insulation to the air stream
- Better thermal seal than fiberglass

12 Dehumidification control

- Hot gas used for “free” reheat
- Tight humidity control without over cooling the space
- Modulating hot gas reheat coil

13 Stainless steel, double sloped drain pan

- Prevents corrosion
- Avoids standing water for high IAQ

16 Durable construction

- Foam-injected panels with an R-value of 7
- Increased insulation value for increased system efficiency
- Double-wall construction for increased indoor air quality

17 Low radiated noise

- Enclosed compressor
- Quiet outdoor fan
- Excellent acoustics at lower speeds

18 Economizer

- Provides free-cooling when outdoor conditions are suitable
- Provides fresh air to meet local requirements
- Integrated economizer operating with mechanical cooling
- Optional demand control ventilation for increased system efficiency

19 2" and 4" slide-out filter racks

- Easy filter changeouts for quick serviceability

20 Energy recovery wheel option

- Up to 75% exhaust air energy recovery
- Up to 60% winter humidification energy savings
- 100% more summer energy recovery than sensible-only devices
- Slide-out accessible w/removable pre-filters
- Meets ASHRAE Standard 90.1

100% outdoor air option

- Low-leak dampers
- Double-wall blades, edge and jam seals
- Modulating 100° temperature rise furnace
- Modulating compressor
- Modulating hot gas reheat

Rebel™ Packaged Cooling and Heat Pump Units—7 to 15 Tons

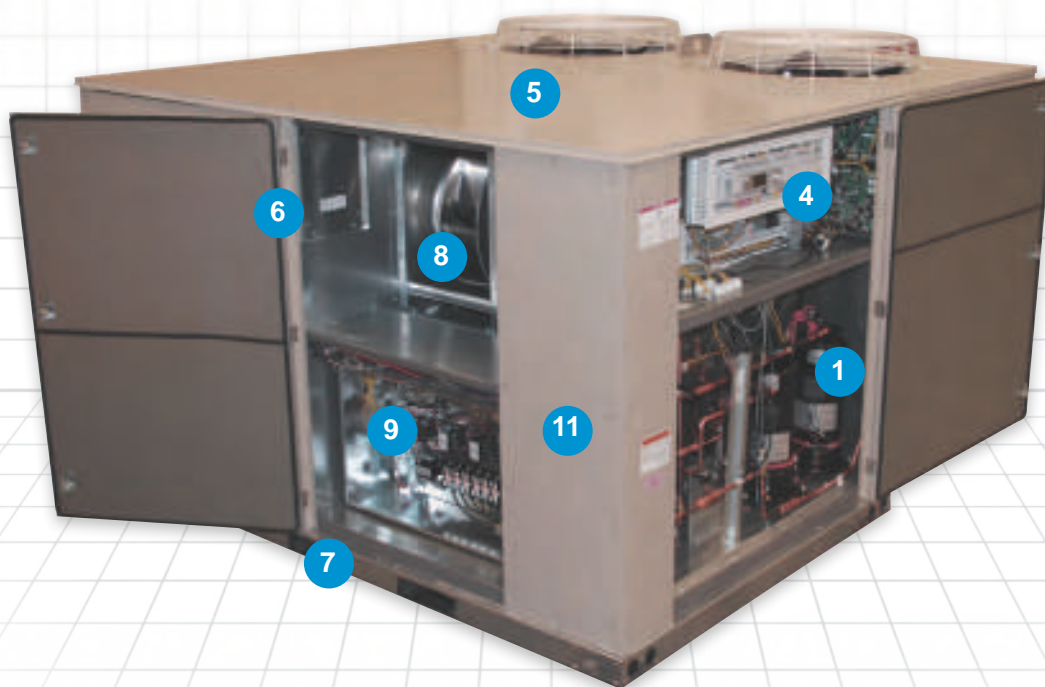

1 Daikin inverter compressor

- Maintains space comfort by matching equipment load to building load
- Optimum efficiency at part load conditions
- Dependable and quiet operation
- Superior discharge air temperature control

2 Daikin heat pump

- Dual fuel for added flexibility
- Hybrid heating with gas furnace

3 Electronic thermostatic expansion valves

- Improves temperature control
- Increases efficiency by safely lowering head pressure

4 MicroTech® III unit controller with D-Net® controls

- Open Choices™ feature provides interoperability with BACnet® and LonWorks® communication options for easy integration with building automation systems
- Unit diagnostics for easy serviceability
- Outdoor air and humidity control logic maintains minimum fresh air intake and optimum humidity levels

5 Seamless top panel

- Seamless construction prohibits leaks

6 Hinged access doors

- ¼–turn latch doors provide easy access to system components for maintenance and service

7 Full-perimeter, forkable base rail

- Allows easy maneuvering and installation

8 ECM supply, return and exhaust fans

- Greatly increases system reliability and efficiency by eliminating belts
- Saves energy at lower ambient temperatures
- Ultra-efficient magnetic rotor
- Built-in inverter eliminates control panel heat and saves energy at lower ambient temperatures
- Totally enclosed motor for increased reliability
- Plenum fan for increased static pressure capabilities

9 Multiple heat options

- Gas furnace with turndowns as high as 10:1
- Electric heat option with SCR for tight DAT control
- Hot water heat option

Rebel Packaged Cooling and Heat Pump Units Features and Options

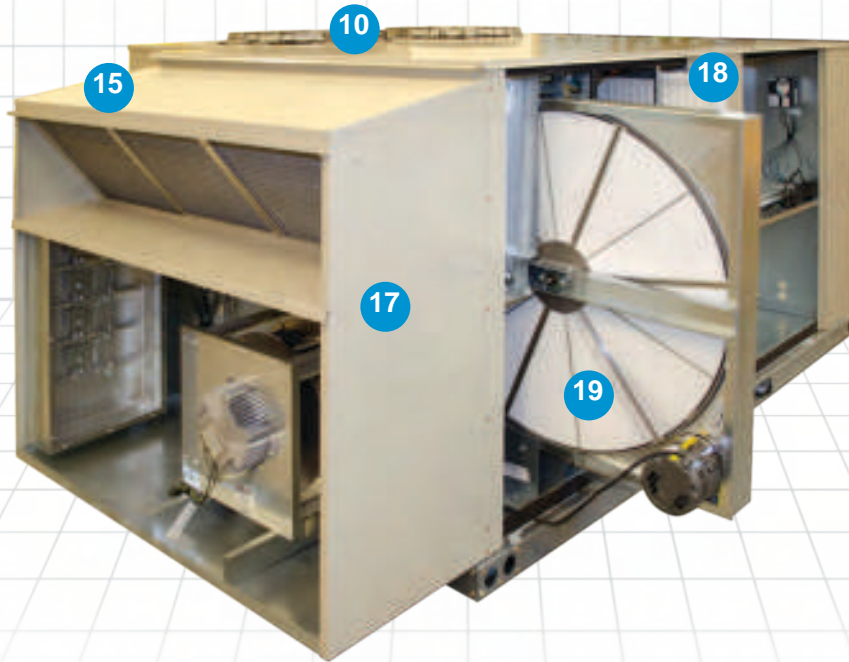

10 Daikin quiet condenser fans

- Molded composite for quiet sound levels
- UV and corrosion resistant

11 Double-wall foam cabinet

- No exposed insulation to the air stream
- Better thermal seal than fiberglass

12 Dehumidification control

- Hot gas used for “free” reheat
- Tight humidity control without over cooling the space
- Modulating hot gas reheat coil

13 Stainless steel, double sloped drain pan

- Prevents corrosion
- Avoids standing water for high IAQ

15 Durable construction

- Foam-injected panels with an R-value of 7
- Increased insulation value for increased system efficiency
- Double-wall construction for increased indoor air quality

16 Low radiated noise

- Enclosed compressor
- Quiet outdoor fan
- Lower speed at lower ambient temperatures

17 Economizer

- Provides free-cooling when outdoor conditions are suitable
- Provides fresh air to meet local requirements
- Integrated economizer operating with mechanical cooling
- Optional demand control ventilation for increased system efficiency

18 2" and 4" slide-out filter racks

- Easy filter changeouts for quick serviceability

19 Energy recovery wheel option

- Up to 75% exhaust air energy recovery
- Up to 60% winter humidification energy savings
- 100% more summer energy recovery than sensible-only devices
- Slide-out accessible w/removable pre-filters
- Meets ASHRAE Standard 90.1

100% outdoor air option

- Low-leak dampers
- Double-wall blades, edge and jam seals
- Modulating 100° temperature rise furnace
- Modulating compressor
- Hot gas reheat

Commercial Rooftop Systems

Physical Data—Standard Units DPS 003 through 015

Model	Small Cabinet				Large Cabinet			
	003	004	005	006	007	010	012	015
Cooling only performance								
Gross Cooling capacity (tons)	3	4	5	6	7.5	10	12	15
Nominal airflow (cfm)	1125	1500	1875	2400	2650	3500	4200	5250
EER ¹	13.5	12.4	13.0	11.6	12.6	12.5	12.1	11.0
IEER ¹ or SEER	16.9	17.0	18.5	19.8	20.6	19.4	18.5	18.0
Heat pump performance⁴								
High Temperature Capacity @ 47°F (MBh)	34	43	54	64	78	110	134	NA
COP @ 47°F or HSPF ¹	9.2	8.9	8.5	3.69	3.66	3.42	3.33	NA
Low Temperature Capacity @ 17°F (MBh)	20	24	33	39	47	64	77	NA
COP @ 17°F ¹	N/A	N/A	N/A	2.54	2.42	2.38	2.32	NA
Electric heat performance								
Control Options	2/4/SCR				4 stage/SCR			
kW (low/medium/high heat)	6/12/18/30				18/36/54/72			
Gas heating performance								
Input capacity (MBh)	80/120/160				200/300/400			
Number of stages (staged option)					2			
Turndown (Modulating options)	5:1				5:1, 10:1			
Gas connection size (mpt)	1/2"				3/4"			
Steady state efficiency					80%			
Heating coil								
Type					Hot Water			
Rows / FPI (high heat/low heat)					(2/10) / (1/8)			
Face area (sq ft)	2.5				5.4			
Compressors								
Quantity / Type	(1) Inverter Scroll				(1) Inverter Scroll, (1) Fixed Speed Scroll			
Number of stages					Modulating			
Refrigerant					R-410A			
Indoor coil								
Rows / FPI	3/16	4/16	4/14	4/14	3/15	4/15	4/15	4/15
Face area (sq ft)	6.0				14	15.4	15.4	15.4
Capacity control					Electronic Expansion Valve (EEV)			
Outdoor coil								
Type					Copper tube			
Rows / FPI	2/16	2/16	3/16	3/16	3/16	4/16	4/16	NA
Indoor fan								
Type					Centrifugal Airfoil (SWSI)			
Quantity / Diameter ²	(1) 12", (1) 14", (1) 16"				(1) 14", (1) 16", (1) 22"	(1) 22"		
Quantity / Diameter ³	(1) 12", (1) 14", (1) 16"				(1) 14", (1) 16", (1) 22"			
Drive type					Direct Drive			
Motor HP range					1.3 / 2.3 / 4.0 / 8.0			
Hot gas reheat coil								
Coil Type					Microchannel			
Control Type					Modulating			
Temperature rise					20°			
Filters								
Type					2", 4"			
Area (sq ft)	7.1				16			
Qty. - size	4 – 16 x 16				6 – 18 x 24			

NOTE: 1. EER and IEER/SEER for Cooling Only VAV Unit
 2. Mixed Outside Air and Return Air units
 3. 100% Outside Air unit only
 4. Heatpump performance for units with back up electric heat

Commercial Rooftop Systems

Physical Data—Unit Weights DPS 003 through 015

Model	Small Cabinet				Large Cabinet			
	003	004	005	006	007	010	012	015
	Weight (lbs.)							
Base Weight ¹	1000	1000	1025	1058	1600	1600	1600	1600
Heatpump	1030	1030	1058	1058	1660	1660	1660	1660
Electric Heat	45	45	45	45	100	100	100	100
Hot Water 2 Row	11	11	11	16.5	30	30	30	30
Hot Water 1 Row	32	32	32	20	31	31	31	31
Gas Heat	75	75	63	93	186	186	186	186
Hot Gas Re-heat	8	8	12	12	28	31	31	31
Economizer	163	163	163	163	308	308	308	308
High capacity coil	105	105	105	105	215	215	215	215

1. Includes standard cooling coil

Fan Weights (lbs.)	
12 Inch (310 mm)	87
14 Inch (360 mm)	91
16 Inch (400 mm)	115
22 Inch (560 mm)	115

Curb Weights (lbs.)		
	14"	24"
003—006	156	230
007—015	200	295

This page intentionally left blank.

Maverick™ I Packaged Cooling and Heat Pump Units—3 to 25 Tons

- Ideal for new, retrofit, or replacement applications on low rise buildings
- Lower installation costs and interior space savings
- Standard low-leak dampers for superior resistance to air leakage and reduced energy costs
- Scroll compressors for efficient cooling operation and dependability
- Two-circuit refrigerant design for high reliability
- Easy access to mechanical components which promotes routine maintenance and can reduce service costs
- Non-corrosive, double-sloped drain pans per ASHRAE Standard 62.1 for high indoor air quality
- Totally enclosed condenser fan motors for reliable operation
- Optional DDC controls
- Optional LONWORKS® or BACnet® communication options for integration into a building automation system
- Non-ozone depleting R-410A refrigerant

For more detail, refer to Catalog 253.

For the most current information, refer to DaikinApplied.com.



Model MPS—3 to 5 tons



Model MPS—6 to 12 tons



Model MPS—15 to 25 tons

Maverick™ I Packaged Cooling and Heat Pump Units—3 to 25 Tons

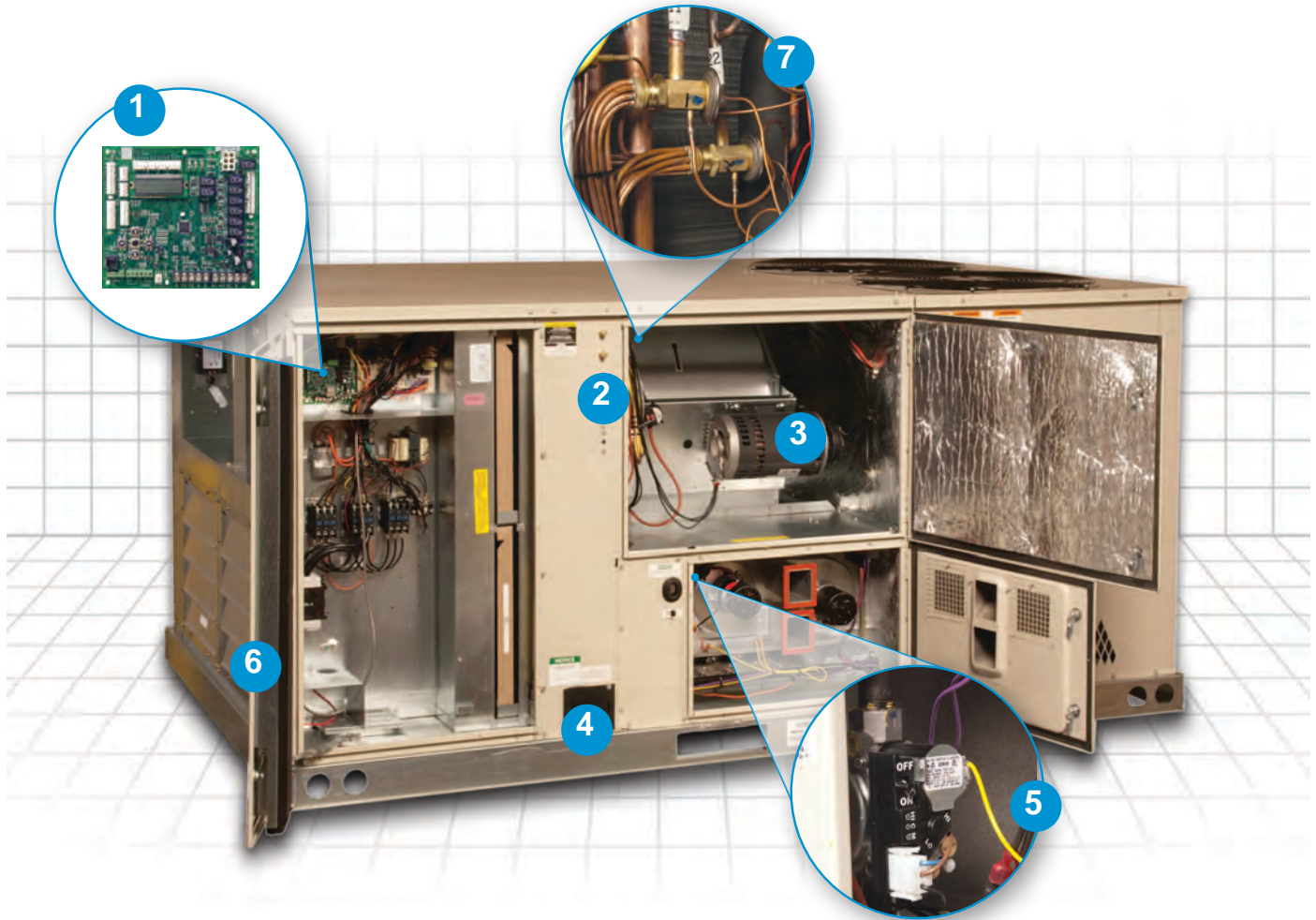

- 1 DDC controller**
 - Open Choices™ integration with BACnet® or LonWORKS® communications
- 2 External refrigerant gauge ports**
 - Easy access for service
 - Allows inspection of refrigerant system performance with all panels installed on the air handling sections
- 3 Slide-out fan**
 - For easy access and serviceability
- 4 Polymer, double sloped drain pan**
 - Prevents corrosion
 - Avoids standing water for high IAQ
 - Sloped per ASHRAE Standard 62.1-2004
- 5 Gas heat**
 - Dual combustion blower for maximum efficiency at low fire
- 6 Hinged access doors**
 - Provides easy access to system components for maintenance and serviceability
 - 1/4 turn latch
- 7 Thermostatic expansion valves**
 - Improves temperature control
 - Increases efficiency
- 8 Totally enclosed condenser fan motors**
 - Prevent electrical damage from rain and condensation
- 9 Tubular heat exchanger**
 - Precise t-stat control for reduced design, installation and life cycle costs
 - Aluminized steel or optional stainless steel design

Maverick I Packaged Cooling and Heat Pump Units Features and Options

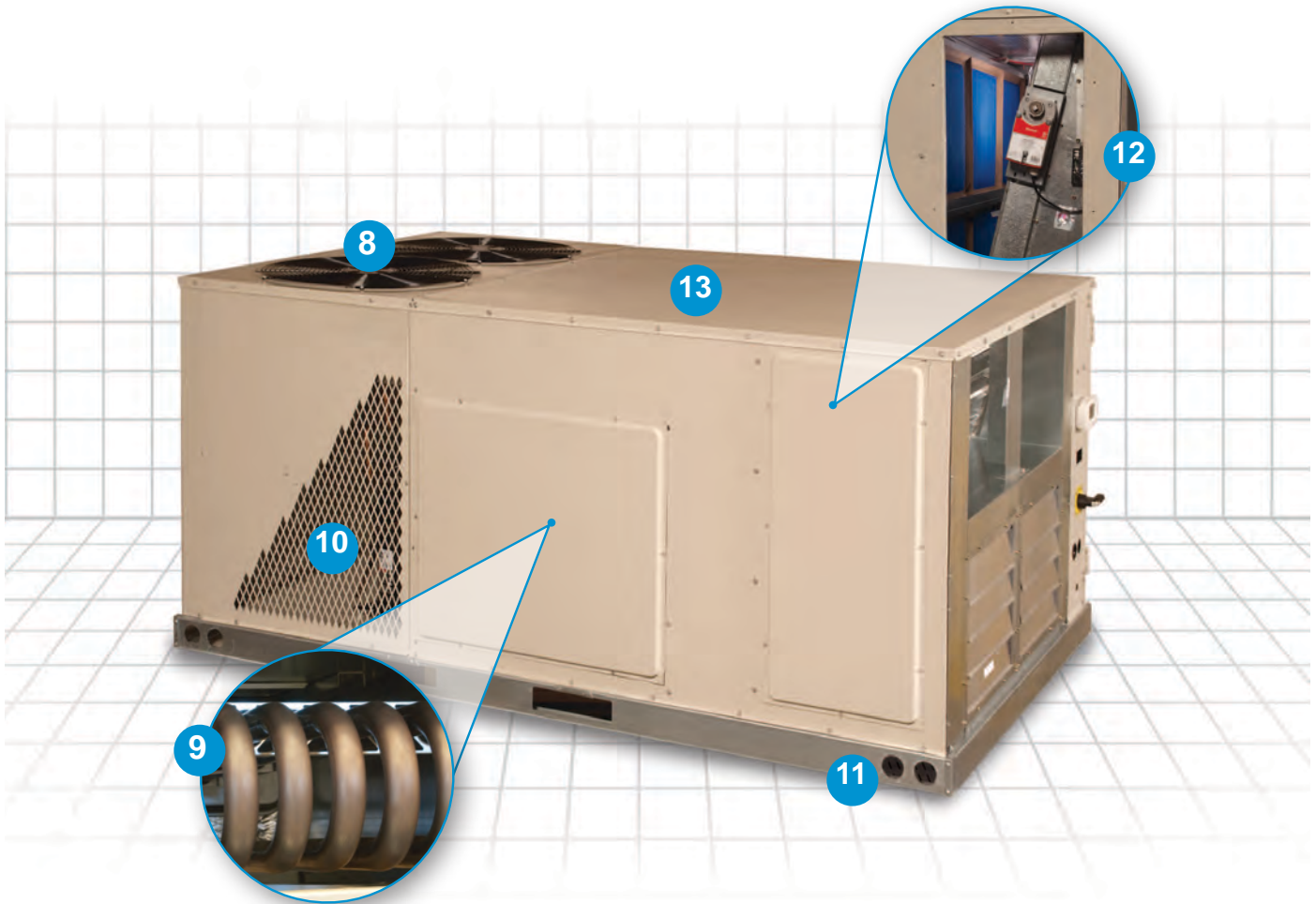

Commercial
Rooftop Systems

10 Scroll compressors

- Provide maximum dependability, efficiency and quiet operation

11 Full perimeter, forkable base rail

- Allows easy maneuvering and installation

12 Economizer

- Provides free cooling when outdoor conditions are suitable
- Provides fresh air to meet code requirements

13 Durable construction

- Powder paint exterior cabinet panels pass 1000-hour ASTM B 117 Salt Spray Test for durability
- 18 gauge sheet metal for durability and low leakage rates
- 3/4-inch, foil face insulation with mechanical fasteners helps prevent insulation damage and fibers in the airstream

Optional energy recovery wheel

- Recovers both heat and moisture energy
- Factory-installed and tested prior to shipment
- Available in economizer configurations with exhaust fans
- AHRI-certified and UL- recognized wheel

Maverick I Packaged Cooling and Heat Pump Units Features and Options



Removable filters

The filter rack has a slide out tray making filter replacement easy.



1/4-turn hinged door access

Hinged access doors with 1/4 turn latches provide easy access for service and maintenance of the unit.



Externally mounted gauge ports

Exterior mounted refrigerant gauge ports provide quick connection points for service technicians and the ports provide accurate readings without having to remove condenser access panels.



Removable drain pan

The drain pan is double-pitched for great indoor air quality (IAQ) and has slide out accessibility for cleaning, further increasing the IAQ of the system.

Commercial Rooftop Systems

Physical Data—MPS 003 through 006

Model	MPS			
	3 ton	4 ton	5 ton	6 ton
Cooling performance¹				
Gross cooling BTU [kW]	36,800 [10.78]	50,000 [14.65]	61,000 [17.87]	76,000 [22.27]
EER/IEER ²	13 / 11.4	13 / 11.4	13 / 11.1	N/A / 11.5
Nominal airflow/AHRI airflow (cfm) [L/s]	1200 [566]	1600 [755]	2000 [944]	2400/2400 [1133/1133]
Net cooling BTU [kW]	35,400 [10.37]	48,000 [14.06]	59,000 [17.29]	73,000 [21.39]
Net sensible BTU [kW]	26,200 [7.68]	35,600 [10.43]	42,000 [12.31]	53,900 [15.79]
Net latent BTU [kW]	9200 [2.7]	12,400 [3.63]	17,000 [4.98]	19,100 [5.6]
Net system power kW	3.1	4.19	5.32	6.31
Compressor(s)				
Type/number	Scroll/1	Scroll/1	Scroll/1	Scroll/1
Gas heating performance³				
Steady stage efficiency %	81	81	81	81
Number of stages	1	1	1	2
Gas connection size	1/2"	1/2"	1/2"	1/2"
Heating input (BtuH) low/high	80,000/120,000	80,000/135,000	100,000/135,000	150,000
Heating output (BtuH)	64,800/97,200	64,800/109,400	81,000/109,400	121,500
Temperature rise °F	30 - 80	30 - 80	25 - 70	30 - 60
Sound⁴				
Outdoor rating (dB)	78	78	83	88
Outdoor coil				
Fin type	Louvered	Louvered	Louvered	Louvered
Tube type	Rifled	Rifled	Rifled	Rifled
Tube size OD (in.) [mm]	3/8 [9.5]	3/8 [9.5]	3/8 [9.5]	3/8 [9.5]
Face area (sq. ft) [sq. m]	16.91 [1.57]	16.56 [1.54]	16.56 [1.54]	13.5 [1.25]
Rows (FPI) [fpcm]	1/22 [9]	2/22 [9]	2/22 [9]	1 / 22 [9]
Indoor coil				
Fin type	Corrugated	Corrugated	Corrugated	Louvered
Tube type	Rifled	Rifled	Rifled	Rifled
Tube size OD (in.) [mm]	3/8 [9.5]	3/8 [9.5]	3/8 [9.5]	0.375 [9.5]
Face area (sq. ft) [sq. m]	5.17 [0.48]	5.17 [0.48]	5.17 [0.48]	13.5 [1.25]
Rows (FPI) [fpcm]	2/17 [7]	3/15 [6]	3/16 [6]	2 / 18 [7]
Refrigerant control	TX valves	TX valves	TX valves	Capillary tube
Drain connection (in.) [mm]	3/4 [19.00]	3/4 [19.0]	1 [19.05]	1 [25.4]
Condenser fan				
Type	Propeller	Propeller	Propeller	Propeller
No. used/diameter (in.) [mm]	1/24 [609.6]	1/24 [609.6]	1/24 [609.6]	2/24 [609.6]
Drive type/No. of speeds	Direct/1	Direct/1	Direct/1	Direct/1
CFM [L/s]	3680 [1737]	3680 [1737]	3680 [1737]	8000 [3775]
Motor hp	1/3	1/3	1/3	2 at 1/3 HP
Motor rpm	1075	1075	1075	1075
Indoor fan				
Type	FC Centrifugal	FC Centrifugal	FC Centrifugal	FC Centrifugal
No. used/diameter (in.) [mm]	1/10x10 [254x254]	1/10x10 [254x254]	1/10x10 [254x254]	1/11x12 [279x305]
No. motors	1	1	1	1
Motor hp	1/2	1/2 - 3/4	3/4 - 1	1 1/2
Motor rpm	1075	1075	1725	1725
Motor frame size	48	48	56	56
Filter				
Fin type	Disposable	Disposable	Disposable	Disposable
Furnished	Yes	Yes	Yes	Yes
(No.) size (in.) [mm]	(2) 1x16x24 [25x406x635]	(2) 1x16x24 [25x406x635]	(2) 1x16x24 [25x406x635]	(6) 2x18x18 [51x457x457]
Refrigerant				
Charge oz. [g]	96 [2722]	165 [4678]	160 [4536]	190.9 [5412]
Weight				
Net weight lbs. [kg]	543 [246]	580 [263]	597 [271]	965 [438]
Shipping weight lbs. [kg]	550 [249]	587 [266]	604 [274]	1002 [455]

- Cooling Performance is rated at 95° F ambient, 80° F entering dry bulb, 67° F entering wet bulb. Gross capacity does not include the effect of fan motor heat. AHRI capacity is net and includes the effect of fan motor heat. Units are suitable for operation to 20% of nominal cfm. Units are certified in accordance with the Unitary Air Conditioner Equipment certification program, which is based on AHRI Standard 210/240 or 360.
- EER and/or IEER are rated at AHRI conditions and in accordance with DOE test procedures.
- Heating Performance limit settings and rating data were established and approved under laboratory test conditions using ANSI standards.
- Ratings shown are for elevations up to 2000 feet. For elevations above 2000 feet, ratings should be reduced at the rate of 4% for each 1000 feet above sea level. Outdoor Sound Rating shown is tested in accordance with AHRI Standard 270.

Commercial Rooftop Systems

Physical Data—MPS 007 through 010

Model	MPS		
	7 1/2 ton	8 ton	10 ton
Cooling performance¹			
Gross cooling BTU [kW]	88,000 [25.78]	101,000 [29.59]	123,000 [36.04]
EER/IEER ²	11.2 / 11.8	11.2 / 12.0	11.2 / 12.0
Nominal airflow /AHRI airflow (cfm) [L/s]	2800/2975 [1321/1404]	3200/3200 [1510/1510]	4000/3750 [1888/1770]
Net cooling BTU [kW]	85,000 [24.9]	97,000 [28.42]	118,000 [34.57]
Net sensible BTU [kW]	66,100 [19.37]	74,000 [21.68]	88,800 [26.02]
Net latent BTU [kW]	18,900 [5.54]	23,000 [6.74]	29,200 [8.56]
Net system power kW	7.53	8.59	10.49
Compressor(s)			
Type/number	Scroll/1	Scroll/2	Scroll/2
Gas heating performance³			
Steady stage efficiency %	81	81	81
No. stages	2	2	2
Gas connection size	1/2" / 3/4"	1/2" / 3/4"	1/2" / 3/4"
Heating input (BtuH) low/high	150,000 / 225,000	150,000 / 225,000	150,000 / 225,000
Heating output (BtuH)	121,000 / 182,250	121,000 / 182,250	121,000 / 182,250
Temperature rise °F	25 - 70	40 - 70	15 - 55
Sound⁴			
Outdoor rating (dB)	88	88	88
Outdoor coil			
Fin type	Louvered	Louvered	Louvered
Tube type	Rifled	Rifled	Rifled
Tube size OD (in.) [mm]	0.375 [9.5]	0.375 [9.5]	0.375 [9.5]
Face area (sq. ft) [sq. m]	27 [2.51]	27 [2.51]	27 [2.51]
Rows (FPI) [fpcm]	1/22 [9]	2/18 [7]	2/22 [9]
Indoor coil			
Fin type	Louvered	Louvered	Louvered
Tube type	Rifled	Rifled	Rifled
Tube size OD (in.) [mm]	0.375 [9.5]	0.375 [9.5]	0.375 [9.5]
Face area (sq. ft) [sq. m]	13.5 [1.25]	13.5 [1.25]	13.5 [1.25]
Rows (FPI) [fpcm]	2/18 [7]	2/18 [7]	3/18 [7]
Refrigerant control	TX valves	TX valves	TX valves
Drain connection (in.) [mm]	1/1 [25.4]	1/1 [25.4]	1/1 [25.4]
Condenser fan			
Type	Propeller	Propeller	Propeller
No. used/diameter (in.) [mm]	2/24 [609.6]	2/24 [609.6]	2/24 [609.6]
Drive type/No. of speeds	Direct/1	Direct/1	Direct/1
CFM [L/s]	8000 [3775]	8000 [3775]	8000 [3775]
Motor hp	2 at 1/3 HP	2 at 1/3 HP	2 at 1/3 HP
Motor rpm	1075	1075	1075
Indoor fan			
Type	FC Centrifugal	FC Centrifugal	FC Centrifugal
No. used/diameter (in.) [mm]	1/15x15 [381x381]	15x15 [381x381]	15x15 [381x381]
No. motors	1	1	1
Motor hp	2 - 3	2 - 3	2 - 3
Motor rpm	1725	1725	1725
Motor frame size	56	56	56
Filter			
Fin type	Disposable	Disposable	Disposable
Furnished	Yes	Yes	Yes
(No.) size (in.) [mm]	(6) 2x18x18 [51x457x457]	(6) 2x18x18 [51x457x457]	(6) 2x18x18 [51x457x457]
Refrigerant			
Charge oz. [g]	190.9 [5412]	154.4/166.6 [4377/4723]	172.8/180.8 [4899/5126]
Weight			
Net weight lbs. [kg]	965 [438]	1095 [497]	1156 [524]
Shipping weight lbs. [kg]	1002 [455]	1132 [513]	1193 [541]

1. Cooling Performance is rated at 95° F ambient, 80° F entering dry bulb, 67° F entering wet bulb. Gross capacity does not include the effect of fan motor heat. AHRI capacity is net and includes the effect of fan motor heat. Units are suitable for operation to 20% of nominal cfm. Units are certified in accordance with the Unitary Air Conditioner Equipment certification program, which is based on AHRI Standard 210/240 or 360.

2. EER and/or IEER are rated at AHRI conditions and in accordance with DOE test procedures.

3. Heating Performance limit settings and rating data were established and approved under laboratory test conditions using ANSI standards.

4. Ratings shown are for elevations up to 2000 feet. For elevations above 2000 feet, ratings should be reduced at the rate of 4% for each 1000 feet above sea level. Outdoor Sound Rating shown is tested in accordance with AHRI Standard 270.

Commercial Rooftop Systems

Physical Data—MPS 012 through 025

Model	MPS			
	12 ton	15 ton	20 ton	25 ton
Cooling performance¹				
Gross cooling BTU [kW]	156,000 [45.71]	188,000 [55.08]	244,000 [71.49]	312,000 [91.42]
EER/IEER ²	11 / 11.4	11.1 / 12.4	11.1 / 11.4	10 / 10.1
Nominal airflow/AHRI airflow (cfm) [L/s]	5000/4400 [2360/2076]	6000/5900 [2831/2784]	8000/7725 [3775/3645]	10000/9475 [4719/4471]
Net cooling BTU [kW]	148,000 [43.36]	182,000 [53.33]	234,000 [68.56]	294,000 [86.14]
Net sensible BTU [kW]	107,600 [31.53]	135,700 [39.76]	171,600 [50.28]	214,100 [62.73]
Net latent BTU [kW]	40,400 [11.84]	46,300 [13.57]	62,400 [18.28]	79,900 [23.41]
Net system power kW	13.39	16.35	21.04	29.39
Compressor(s)				
Type/number	Scroll/2	Scroll/2	Scroll/2	Scroll/2
Gas heating performance³				
Steady stage efficiency %	81	81	81	81
No. stages	2	2	2	2
Gas connection size	1/2" / 3/4"	3/4"	3/4"	3/4"
Heating input (BtuH)	150,000 / 252,000	250,000 / 350,000	300,000 / 400,000	300,000 / 400,000
Heating output (BtuH)	121,500 / 204,000	203,000 / 284,000	243,000 / 324,000	243,000 / 324,000
Temperature rise °F	15 - 55	15 - 60	15 - 55	10 - 45
Sound⁴				
Outdoor rating (dB)	88	91	91	92
Outdoor coil				
Fin type	Louvered	Louvered	Louvered	Louvered
Tube type	Microchannel	Rifled	Rifled	Rifled
Tube size OD (in.) [mm]	1 [25.4]	0.375 [9.5]	0.375 [9.5]	0.375 [9.5]
Face area (sq. ft) [sq. m]	27 [2.51]	53.3 [4.95]	53.3 [4.95]	53.3 [4.95]
Rows (FPI) [fpcm]	2 / 20 [8]	1/22 [9]	2/22 [9]	2/22 [9]
Indoor coil				
Fin type	Louvered	Louvered	Louvered	Louvered
Tube type	Rifled	Rifled	Rifled	Rifled
Tube size OD (in.) [mm]	0.375 [9.5]	0.375 [9.5]	0.375 [9.5]	0.375 [9.5]
Face area (sq. ft) [sq. m]	13.5 [1.25]	26.67 [2.48]	26.67 [2.48]	26.67 [2.48]
Rows (FPI) [fpcm]	4 / 15 [6]	2/18 [7]	3/13 [5]	4/15 [6]
Refrigerant control	TX valves	TX valves	TX valves	TX valves
Drain connection (in.) [mm]	1 [25.4]	1 [25.4]	1 [25.4]	1 [25.4]
Condenser fan				
Type	Propeller	Propeller	Propeller	Propeller
No. used/diameter (in.) [mm]	2/24 [609.6]	4/24 [609.6]	6/24 [609.6]	6/24 [609.6]
Drive type/No. of speeds	Direct/1	Direct/1	Direct/1	Direct/1
CFM [L/s]	8000 [3775]	16,000 [7550]	19,800 [9344]	19,800 [9344]
Motor hp	2 at 1/2 HP	4 at 1/3 HP	6 at 1/3 HP	6 at 1/3 HP
Motor rpm	1075	1075	1075	1075
Motor frame size	56/184	56/184	184/213	213/215
Indoor fan				
Type	FC Centrifugal	FC Centrifugal	FC Centrifugal	FC Centrifugal
No. used/diameter (in.) [mm]	1/15x15 [381x381]	2/18x9 [457x229]	2/18x9 [457x229]	2/18x9 [457x229]
No. motors	1	1	1	1
Motor hp	3, 5	3, 5	5, 7-1/2	7-1/2, 10
Motor rpm	1725	1725	1725	1725
Filter				
Fin type	Disposable	Disposable	Disposable	Disposable
Furnished	Yes	Yes	Yes	Yes
(No.) size (in.) [mm]	(6) 2x18x18 [51x457x457]	(8) 2x25x20 [51x635x508]	(8) 2x25x20 [51x635x508]	(8) 2x25x20 [51x635x508]
Refrigerant				
Charge oz. [g]	159.2/156 [4513/4423]	205/211 [5812/5982]	402/331 [11397/9384]	339/357 [9611/10121]
Weight				
Net weight lbs. [kg]	1230 [558]	2000 [907]	2341 [1062]	2433 [1104]
Shipping weight lbs. [kg]	1267 [575]	2100 [953]	2441 [1107]	2533 [1149]

1. Cooling Performance is rated at 95° F ambient, 80° F entering dry bulb, 67° F entering wet bulb. Gross capacity does not include the effect of fan motor heat. AHRI capacity is net and includes the effect of fan motor heat. Units are suitable for operation to 20% of nominal cfm. Units are certified in accordance with the Unitary Air Conditioner Equipment certification program, which is based on AHRI Standard 210/240 or 360.

2. EER and/or IEER are rated at AHRI conditions and in accordance with DOE test procedures.

3. Heating Performance limit settings and rating data were established and approved under laboratory test conditions using ANSI standards.

4. Ratings shown are for elevations up to 2000 feet. For elevations above 2000 feet, ratings should be reduced at the rate of 4% for each 1000 feet above sea level. Outdoor Sound Rating shown is tested in accordance with AHRI Standard 270.

Maverick™ II Packaged Singlezone Cooling Units—15 to 75 Tons

- VAV or constant volume operation
- Optional hot gas reheat for dehumidification control
- Optional energy heat recovery wheel
- Double wall construction
- Low leak damper
- AF fans for efficient operation
- Stainless steel drain pan
- Building pressure control option for exhaust fan
- Controls flexibility—MicroTech® III controls with our Open Choices™ feature for easy integration with the BAS of your choice
- Non-ozone depleting R-410A refrigerant

For more detail, refer to Catalog 250.

For the most current information, refer to DaikinApplied.com.



Model MPS—15 to 75 tons



Maverick II Packaged Singlezone Cooling Unit Features and Options



Outside air dampers

- Low leakage - 4 cfm/ft² for ASHRAE 90.1-2004
- Double-wall blade
- Blade edge and jamb seals



Energy recovery wheel

- Increases air conditioning capacity by approximately 25%
- Recovers sensible and latent energy by 70-75%
- Single point power connection
- Factory installed package with controls and optional bypass dampers



Fan

- AF, SWSI
- Fixed pitch sheave
- Class II construction
- Concentric locking bearing
- Standard 1" seismic spring isolation



Exhaust air

- Direct drive prop exhaust
- 80 - 100% supply airflow
- Staged on OA position control
- Building pressure control via VFD application

Maverick™ II Packaged Singlezone Cooling Units—15 to 75 Tons



1 Durable construction

- Pre-painted exterior cabinet panels pass 750-hour ASTM B 117 Salt Spray Test for durability
- Double-wall construction protects insulation and provides wipe-clean surface

2 2"¼" combination filter rack

- Provides more flexibility to meet building filtration requirements
- 2" MERV 6 filters shipped with unit, owner preference at building occupancy

3 Low leak outside air dampers

- 4 cfm/ft² leakage rate to meet ASHRAE Standard 90.1
- Double-wall blades
- Blade edge and jamb seals

4 Exhaust fans with building pressure control

- Provide better building operations, higher customer satisfaction

5 Optional energy recovery wheel

- Meets ASHRAE Standard 90.1
- Factory installed
- Single point power

6 Hinged access doors

- On both sides of unit for easy access to all components
- Easy open, quarter-turn latches
- Double-wall construction protects insulation during maintenance

7 Airfoil plenum fan

- Energy efficient and quiet
- 1" seismic spring isolators for superior vibration control
- Premium efficiency motor is standard
- Vibration transmissionibility of less than 5%

Maverick II Packaged Singlezone Cooling Unit Features and Options

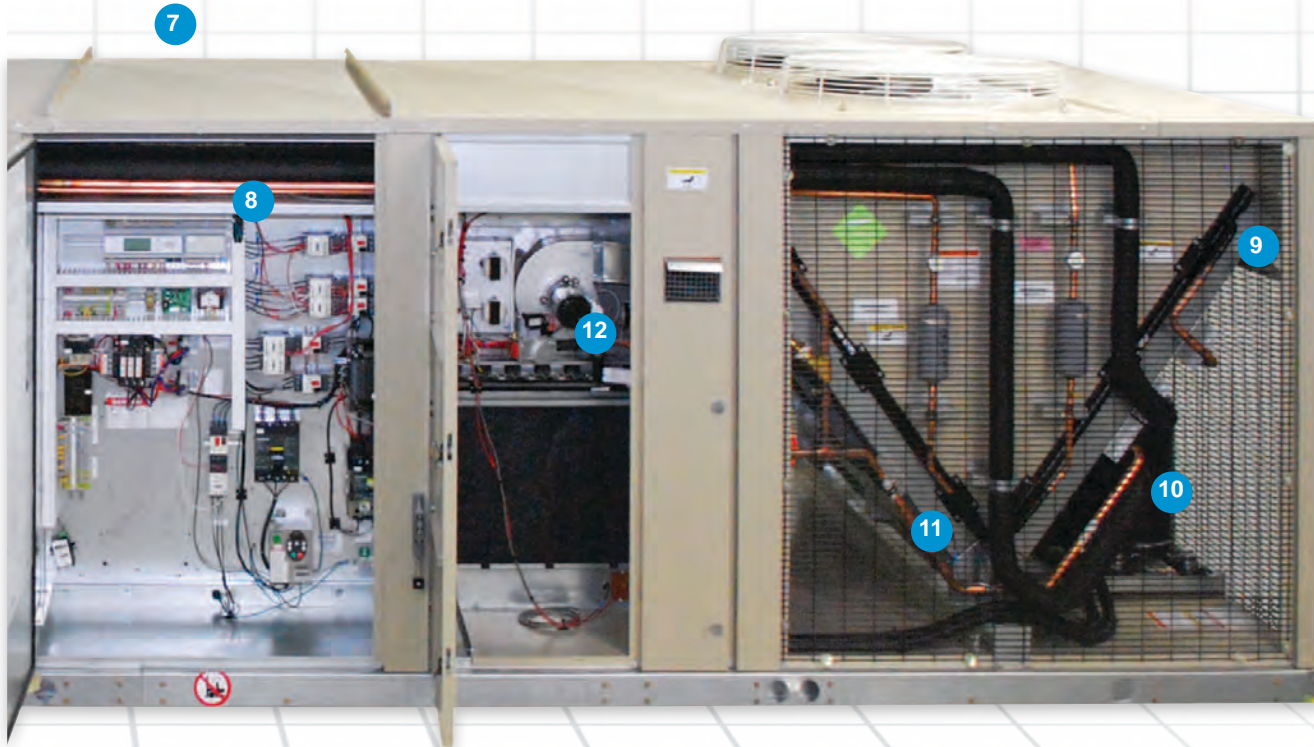

8 MicroTech® III unit controller

- Open Choices™ feature provides interoperability with BACnet® or LONWORKS® communications for easy integration into your building automation system of choice
- Outdoor air and humidity control logic maintains minimum fresh air intake and optimum humidity levels

9 Microchannel condenser coils

- Proven technology from the automotive industry
- Suited for R-410A
- All aluminum design
- No corrosion between fins, tubes and header
- LEED® credit for enhanced refrigeration management

10 Scroll compressors

- Provide maximum dependability, efficiency and quiet operation

11 R-410A refrigerant

- No ozone depletion potential or phase-out date
- EER per ASHRAE 90.1 2010
- Dual refrigerant circuits provide redundancy for high unit reliability

12 Gas heat

- Tubular heat exchanger
- Aluminized steel or optional stainless steel tubes
- Staged or modulating control

Optional electric heat

- 4-stage control
- Operational safeties
- High-limit temperature switch
- Single point power connection

Optional hot water heat

- Low and high capacity options
- DDC control ready with 0–10 volt wiring harness for water control valve
- Vestibule for field installed control valve package

Commercial Rooftop Systems

Physical Data—MPS 015 through 026

Model	MPS							
	015		017		020		026	
Cooling performance								
Gross cooling capacity (tons)	16.0		18.5		21.7		25.3	
Nominal airflow (cfm)	6000		7000		8000		10,000	
Maximum EER	11.0–11.1		11.0–11.2		10.0		10.8	
Maximum IEER	11.2–11.5		11.2–12.0		11.2		12.8	
Gas heating performance								
Low heat MBH (input/output) ¹	240/192		240/192		240/192		240/192	
Number of stages (low heat)	2		2		2		2	
Turndown (low heat) ²	4:1		4:1		4:1		4:1	
Gas connection pipe size/qty (low heat)	3/4"/1		3/4"/1		3/4"/1		3/4"/1	
High heat MBH (input/output) ¹	480/384		480/384		480/384		480/384	
Number of stages (high heat)	4		4		4		4	
Gas connection pipe size/qty (high heat)	3/4"/2		3/4"/2		3/4"/2		3/4"/2	
Turndown (high heat) ²	8:1		8:1		8:1		8:1	
Steady state efficiency	80%		80%		80%		80%	
Hot water heating performance								
Face area (sq ft)	12.2		12.2		12.25		12.25	
Rows/FPI (low heat)	1/11		1/11		1/14		1/14	
Coil model (low heat)	5WB		5WB		5WB		5WB	
Connection sizes/type (low heat) ²	ODM Sweat		ODM Sweat		ODM Sweat		ODM Sweat	
Rows/FPI (high heat)	2/12		2/12		2/9		2/9	
Coil model (high heat)	5WB		5WB		5WS		5WS	
Connection sizes/type (high heat) ²	ODM Sweat		ODM Sweat		ODM Sweat		ODM Sweat	
Electric heating performance								
Number of stages	4		4		4		4	
kW (low/medium/high heat)	18/36/54		18/36/54		36/54/72		36/54/72	
Compressors								
Type/number	Scroll/2		Scroll/2		Scroll/3		Scroll/3	
Number of stages	2		2		4		4	
Evaporator coils								
Rows	4		4		4		4	
FPI	14		14		13		13	
Face area (sq ft)	18.2		18.2		18.2		18.2	
Capacity control	TXV		TXV		TXV		TXV	
Hot gas reheat								
Coil type	Microchannel		Microchannel		Microchannel		Microchannel	
Control type	Modulating		Modulating		Modulating		Modulating	
Face area (sq ft)	14.1		14.1		14.1		14.1	
Condenser coils								
Fin type	Enhanced		Enhanced		Enhanced		Enhanced	
FPI	18		18		18		18	
Face area (sq ft)	18.1		18.1		18.1		18.1	
Outdoor fans								
Type	Propeller		Propeller		Propeller		Propeller	
Number - diameter	2 - 26"		2 - 26"		2 - 26"		2 - 26"	
Drive type/number of speeds	Direct/1		Direct/1		Direct/1		Direct/1	
Indoor fans								
Type	AF - SWSI		AF - SWSI		AF - SWSI		AF - SWSI	
Number - diameter	1 - 18"		1 - 18"		1 - 20"		1 - 22"	
Drive type	Fixed sheave		Fixed sheave		Fixed sheave		Fixed sheave	
Isolation	1" spring		1" spring		1" spring		1" spring	
Number of motors	1		1		1		1	
Motor hp range	1.5 - 10		1.5 - 10		2 - 15		2 - 15	
Motor nominal rpm	1800		1800		1800		1800	
Motor efficiency	Premium		Premium		Premium		Premium	
Filters								
Type	2", MERV 7							
Area (sq ft)	24		24		24		24	
Qty. - size	6 - 24" x 24"		6 - 24" x 24"		6 - 24" x 24"		6 - 24" x 24"	
Total unit weight								
Weight (lbs)	Cooling		Cooling		Cooling		Cooling	
	2650		2700		2955		3055	
Curb								
Height	14"	24"	14"	24"	14"	24"	14"	24"
Weight (lbs)	341	501	341	501	341	501	341	501

1. Piping connections are given with a male outside diameter dimension, brazed connection.

2. Modulating burner only.

3. Base unit weight includes Economizer, VFDs, and the smallest supply fan available. Heating units include maximum gas heat.

Commercial Rooftop Systems

Physical Data—MPS 030 through 050

Model	MPS							
	030		035		040		050	
Cooling performance								
Gross cooling capacity (tons)	30.0		34.0		40.0		50.0	
Nominal airflow (cfm)	12,000		14,000		16,000		20,000	
Maximum EER	10.2–10.4		9.9–10.1		10.0–10.3		9.8–10.2	
Maximum IEER (CAV-VAV)	12.2–13.1		11.4–12.3		11.8–13.2		11.6–12.3	
Gas heating performance								
Low heat MBH (input/output) ¹	300/240		300/240		400/320		400/320	
Number of stages (low heat)	2		2		2		2	
Turndown (low heat) ²	4:1		4:1		4:1		4:1	
Gas connection pipe size/qty (low heat)	3/4"/1		3/4"/1		3/4"/1		3/4"/1	
High heat MBH (input/output) ¹	600/480		600/480		800/640		800/640	
Number of stages (high heat)	4		4		4		4	
Gas connection pipe size/qty (high heat)	3/4"/2		3/4"/2		3/4"/2		3/4"/2	
Turndown (high heat) ²	8:1		8:1		8:1		8:1	
Steady state efficiency	80%		80%		80%		80%	
Hot water heating performance								
Face area (sq ft)	19.25		19.25		19.25		19.25	
Rows/FPI (low heat)	1/12		1/12		1/11		1/11	
Coil model (low heat)	5WB		5WB		5WH		5WH	
Connection sizes/type (low heat) ²	ODM Sweat		ODM Sweat		ODM Sweat		ODM Sweat	
Rows/FPI (high heat)	2/10		2/10		2/13		2/13	
Coil model (high heat)	5WS		5WS		5WS		5WS	
Connection sizes/type (high heat) ²	ODM Sweat		ODM Sweat		ODM Sweat		ODM Sweat	
Electric heating performance								
Number of stages	4		4		4		4	
kW (low/medium/high heat)	54/72/90		54/72/90		72/90/108		72/90/108	
Compressors								
Type/number	Scroll/3		Scroll/3		Scroll/4		Scroll/4	
Number of stages	5		5		5		5	
Evaporator coils								
Rows	4		4		4		4	
FPI	12		12		12		12	
Face area (sq ft)	25.4		25.4		29.4		35.7	
Capacity control	TXV		TXV		TXV		TXV	
Hot gas reheat coils								
Coil type	Microchannel		Microchannel		Microchannel		Microchannel	
Control type	Modulating		Modulating		Modulating		Modulating	
Face area (sq ft)	19.9		19.9		26.8		26.8	
Condenser coils								
Fin type	Enhanced		Enhanced		Enhanced		Enhanced	
FPI	18		18		18		18	
Face area (sq ft)	13.4/27.5		13.4/27.5		13.4/27.5		27.5 (x 2)	
Outdoor fans								
Type	Propeller		Propeller		Propeller		Propeller	
Number - diameter	3 - 26"		3 - 26"		4 - 26"		4 - 26"	
Drive type/number of speeds	Direct/1		Direct/1		Direct/1		Direct/1	
Indoor fans								
Type	AF - SWSI		AF - SWSI		AF - SWSI		AF - SWSI	
Number - diameter	1 - 24"		1 - 24"		1 - 30"		1 - 30"	
Drive type	Fixed sheave		Fixed sheave		Fixed sheave		Fixed sheave	
Isolation	1" spring		1" spring		1" spring		1" spring	
Number of motors	1		1		1		1	
Motor hp range	5 - 20		5 - 20		7-1/2 - 30		7-1/2 - 30	
Motor nominal rpm	1800		1800		1800		1800	
Motor efficiency	Premium		Premium		Premium		Premium	
Filters								
Type	2", MERV 6							
Area (sq ft)	32		32		36		44	
Qty. - size	8 - 24" x 24"		8 - 24" x 24"		8 - 24" x 24"/4 - 18" x 24"		8 - 24" x 24"/4 - 18" x 24"	
Total unit weight								
Weight (lbs)	Cooling		Cooling		Cooling		Cooling	
	3660		3660		4685		4985	
Curb								
Height	14"	24"	14"	24"	14"	24"	14"	24"
Weight (lbs)	341	501	341	501	481	501	481	501

1. Piping connections are given with a male outside diameter dimension, brazed connection.

2. Modulating burner only

3. Base unit weight includes Economizer, VFDs, and the smallest supply fan available. Heating units include maximum gas heat.

Commercial Rooftop Systems

Physical Data—MPS 062 through 075

Model	MPS		
	062	070	075
Cooling performance			
Nominal gross cooling capacity (tons)	62.0	70.0	75.0
Nominal airflow (cfm)	24,000	26,000	28,000
Maximum EER (standard coil/large coil)	10.0–10.3	9.7	9.3
Maximum IEER (standard coil/large coil)	12.4–12.7	13.0–13.6	12.2–12.9
Gas heating performance			
Low heat MBH (input/output) ¹	500/400	500/400	500/400
Gas connection pipe size/qty (low heat)	1"/1	1"/1	1"/1
Medium heat MBH (input/output) ¹	600/480	600/480	800/640
Gas connection pipe size/qty (medium heat)	1 1/4"/1	1 1/4"/1	1 1/4"/1
High heat MBH (input/output) ¹	980/790	980/790	980/790
Gas connection pipe size/qty (high heat)	1 1/4"/1	1 1/4"/1	1 1/4"/1
Number of stages - all furnaces (high heat)	Mod	Mod	Mod
Turndown - all furnaces (high heat) ²	3:1	3:1	3:1
Steady state efficiency - all furnaces	80%	80%	80%
Hot water heating performance			
Face area (sq ft)	29.7	29.7	29.7
Type—rows (standard / high capacity)	5WH-1 / 5WS-2	5WH-1 / 5WS-2	5WH-1 / 5WS-2
FPI	9	9	9
Electric heating performance			
Number of stages	4	4	4
kW (low/medium/high heat)	100/120/160	100/120/160	100/120/160
Compressors			
Type/number	Scroll/4	Scroll/6	Scroll/6
Number of stages	4	6	6
Evaporator coils			
Rows	5	5	5
FPI	10	10	10
Face area (sq ft)	39.5 or 47.1	47.1	47.1
Capacity control	TXV	TXV	TXV
Condenser coils			
Fin type	Enhanced	Enhanced	Enhanced
FPI	18	18	18
Face area (sq ft)	32.1 × 2	37.3 × 2	37.3 × 2
Outdoor fans			
Type	Propeller	Propeller	Propeller
Number - diameter	6 - 26"	6 - 26"	8 - 26"
Drive type/number of speeds	Direct/1	Direct/1	Direct/1
Indoor fans			
SWSI AF	1 - 44"		
DWDI AF	1 - 30" or 1 - 33"		
Drive type	Fixed sheave		
Isolation	2" spring		
Number of motors	1		
Motor hp range	5 - 40		
Motor nominal rpm	1800		
Motor efficiency	Premium		
Filters			
Qty. - type / sq. ft.	Merv 6 angular	(7) 16 × 20 and (21) 16 × 25 / 73 sq. ft.	
	6" Merv 11 or 12" Merv 14	(4) 12 × 24 and (8) 24 × 24 / 40 sq. ft. standard air flow (8) 12 × 24 and (8) 24 × 24 / 48 sq. ft. high air flow	

1. Heating output is for standard conditions at sea level.
2. Modulating burner only.

RoofPak™ Packaged Singlezone Heating and Cooling Units—15 to 140 Tons

- Flexible, modular construction with walk-in access
- 100% make-up air, dehumidification, VAV, or constant volume operation
- Multiple factory-integrated options for customized flexibility such as return and exhaust fans, draw-through or blow-through final filters, walk-in access to any section, blenders, face and bypass dampers and sound attenuators
- Controls flexibility—MicroTech® III controls with our Open Choices™ feature for easy integration with the BAS of your choice
- Heavy duty construction and independent certification (optional) confirm the Daikin RoofPak complies with IBC seismic requirements
- Non-ozone depleting R-410A refrigerant

For more detail, refer to Catalogs 214, 219, and 220.

For the most current information, refer to DaikinApplied.com.



Model RPS/RFS/RCS—15 to 140 tons, air-cooled blow-through and draw-through configurations

Model RDT—45 to 140 tons, air-cooled draw-through configuration

Blow-Through Optimal Air vs. Standard Draw-Through

- Customize your unit to fit the application and building load
- Blow-through arrangements provides greater sensible heat ratios and a colder unit leaving air temperature per ton
- Draw-through arrangement provides more dehumidification per ton

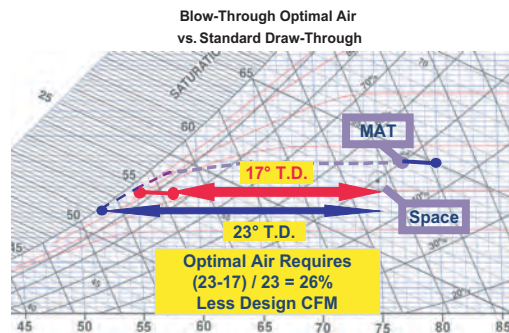

Daikin blow-through coils and fan flexibility reliably allow cost saving “optimal air” design



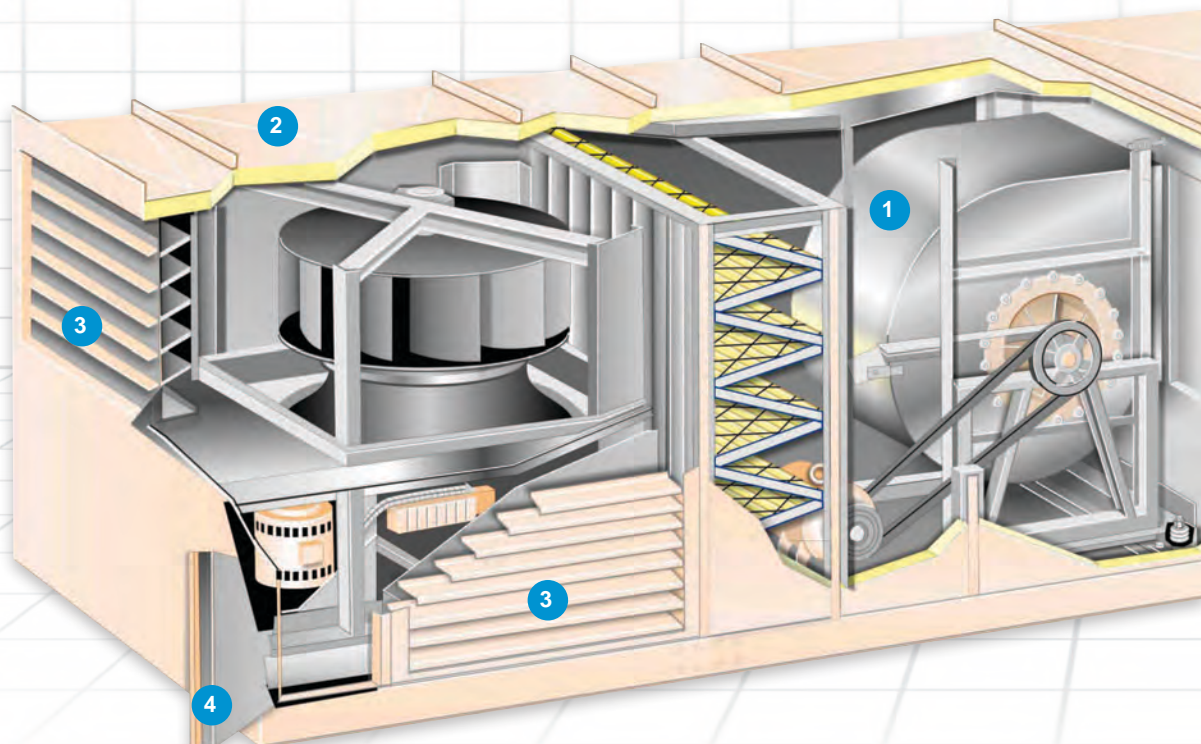

1 Airfoil fans

- More energy efficient and quieter than forward curved fans
- Double width, double inlet (DWDI) or single width, single inlet (SWSI) plenum fans



2 Durable construction

- Pre-painted exterior cabinet panels pass ASTM B 117 Salt Spray Test for durability
- Capped seams prevent water leaks into the cabinet
- Cross-broken top panels eliminate standing water
- Double-wall construction protects R-6.5 insulation and provides wipe clean surface
- Stainless steel, sloped drain pans eliminate standing water

3 Economizer

- Outside air enters from both sides, improving mixing for better temperature control
- Patented DesignFlow™ Precision Outdoor Air Control System accurately measures and maintains minimum outdoor air intake
- Patented UltraSeal™ low leak dampers minimize air leakage, reducing energy costs

4 Hinged access doors

- On both sides of every section for easy access to all components
- Single lever latch and door holders provide easy entry and support routine maintenance
- Double-wall construction protects insulation during maintenance

5 Optional blank sections

- Available throughout unit to factory-mount air blenders, carbon or charcoal filters, sound attenuators, humidifiers, or other specialty equipment
- Allow customization for maximum system performance and efficiency
- Reduce design and installation costs



RoofPak Packaged Singlezone Heating and Cooling Units Features and Options

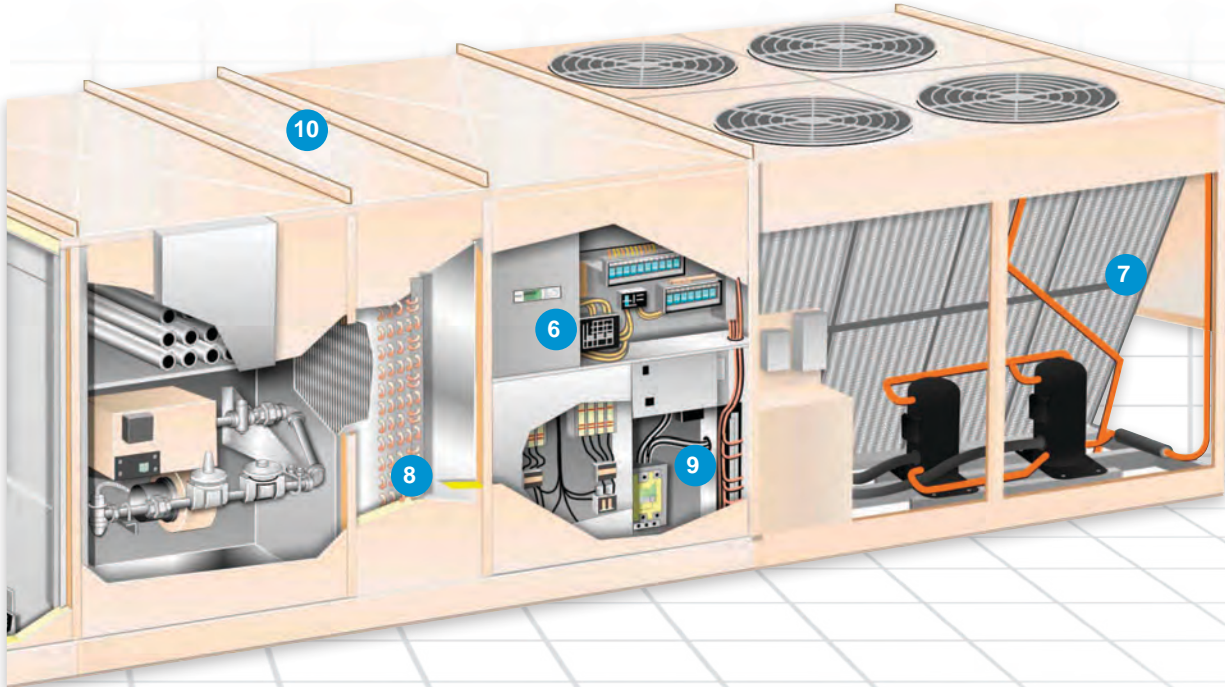

6 MicroTech® III control system

- Factory-installed and tested to minimize costly field commissioning
- Open Choices™ feature for easy integration with the BAS of your choice using open, standard protocols such as BACnet® or LONWORKS®
- Easily accessed for system diagnostics and adjustments via a keypad/display on unit
- Minimum outdoor air and humidity control logic for fresh air intake and optimum humidity levels
- Optionally add a remote keypad and display that is identical to the unit mounted user interface



7 High efficiency condensing section

- Open air design for unrestricted airflow and access to compressors and refrigerant piping
- Up to 6 steps of compressor capacity control, with reheat or hot gas bypass on each circuit, provides a stable discharge temperature and humidity control
- Two refrigerant circuits and multiple scroll compressors offer unsurpassed reliability and part load efficiency

8 Blow-through or draw-through cooling coils and filters

- Both standard and premium efficiency options are offered. Premium efficiency EERs and IEERs exceed ASHRAE 90.1-2010 by over 5% and Meet CEE Tier I and II requirements
- Sound attenuating discharge plenum is provided

9 Factory-mounted variable frequency drives

- Control fan motor speed for lower fan operating costs and sound levels in VAV systems
- Three brands offered including the Daikin MD4 & MD5 which are specially designed for HVAC and Daikin applications



10 Modulating hot gas reheat coil

- Hot refrigerant gas from the compressor is metered to a reheat coil to reheat dehumidified air to comfort levels without requiring wasteful reheat energy
- Robust micro-channel reheat coils provide more heat per square foot, greatly reduce the refrigerant charge and therefore enhance reliability

RoofPak Packaged Singlezone Heating and Cooling Units Features and Options

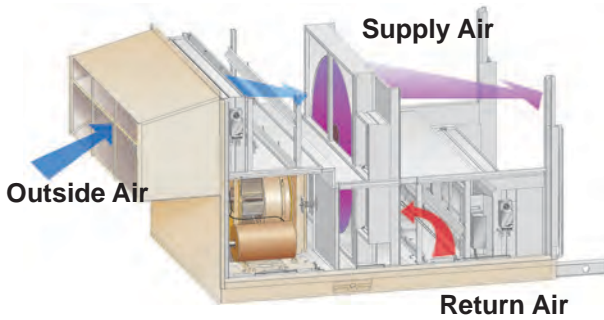

Optional energy recovery wheel

- Recovers approximately 75% of the energy from exhaust air stream
- Reduces mechanical refrigeration, heating, and humidifying capacities to be reduced, offsetting the initial cost of the energy recovery wheel
- Cuts winter humidification energy costs by up to 60%
- Provides 100% more summer energy recovery than sensible-only energy recovery devices
- Helps provide a comfortable and affordable indoor environment
- Satisfies ASHRAE Standard 90.1 requirements for energy recovery on applications involving more than 70% minimum outdoor air and 5000 total cfm
- Includes filtration on both outside air and exhaust air paths to maintain the efficiency of the energy recovery wheel

Quiet condenser option

- With this option, sound power at the unit is reduced by an average of 7 dB when compared to standard units.
- Quiet condensers are specially engineered to reduce radiated noise and improve condenser fan efficiency
- Aerodynamic, airfoil, sickle-shaped blades and bell mouth orifices improve fan efficiency
- Each fan includes seven blades complete with serrated trailing edges and special blade tip to break up turbulence and reduce noise
- Individual compressor sound blankets are provided to reduce noise

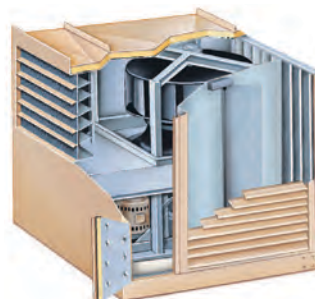

Return or exhaust fans

- Customize the unit to fit the application and return duct pressure drop
- Return fans provide better building pressure and ventilation control as return duct pressure drop increases
- Exhaust fans can save energy as return duct pressure drop requirements decrease

SuperMod™ high turndown gas burners

- Full 20:1 turndown and multiple sizes enable precise temperature control at reduced design, installation, and life cycle costs
- Maintain comfortable tenant environment in VAV, 100% make-up air, and dehumidification applications

DesignFlow™ precision Ventilation air control system

- Accurately measures and maintains minimum ventilation air intake to satisfy IAQ standards

Optional UVGI lights

- Improves IAQ by destroying microorganisms on coil and drain pan surfaces
- Includes door interlocks to prevent eye contact with the UV-C ultraviolet light
- Satisfies GSA requirement for UVGI lights downstream of all cooling coils

Applied Rooftop Systems

Physical Data—RPS 015D through 042D

Data		Unit size					
		015D/016D	020D/021D	025D/026D	030D/031D	035D	042D
Compressor	Quantity—hp	2–7	1–10, 2–4.5	1–11.5, 2–5.5	1–13, 2–6	4–7.5	4–8.5
	Capacity control	100-50-0	100-78-22-0	100-78-22-0	100-78-22-0	100-75-50-25-0	100-75-50-25-0
Condenser fans	Qty—diameter (in)	2–26	2–26	2–26	4–26	4–26	4–26
Condenser fan motors	Qty—hp	2–1.0	2–1.0	2–1.0	4–1.0	4–1.0	4–1.0
Supply fans	Type	Forward curved LP				Forward curved LP/MP	
	Qty—diameter (in)	2–15×6	2–15×6	2–15×6	2–15×6	1–24	1–24
	Qty—diameter (in)	2–15×15	2–15×15	2–15×15	2–15×15	–	–
	Airflow range (cfm)	4000–12000	4000–12000	5400–16000	5400–16000	5400–17550	5400–17550
	Motor hp range	1–20	1–20	1–20	1–20	1–25	1–25
	Type	DWDI airfoil					
	Qty—diameter (in)	1–20	1–20	1–20	1–20	1–24	1–24
	Airflow range (cfm)	4000–10000	4000–12000	5400–16000	5400–16000	5400–17550	5400–17550
Motor hp range	1–20	1–20	1–20	1–20	1–25	1–25	
Return fans	Type	Forward curved					
	Diameter (in)	2–15×15	2–15×15	2–15×15	2–15×15	–	–
	Airflow range (cfm)	4000–10000	4000–12000	5400–16000	5400–16000	–	–
	Motor hp range	1–10	1–10	1–10	1–10	–	–
	Type	SWSI airfoil					
	Qty—diameter (in)	1–30	1–30	1–30	1–30	1–30, 1–40	1–30, 1–40
	Airflow range (cfm)	4000–10000	4000–12000	5400–16000	5400–16000	5400–17550	5400–17550
Motor hp range	1–10	1–10	1–10	1–10	1–10	1–10	
Evaporator coils	Rows	4, 5	4, 5	4, 5	4, 5	4, 5	4, 5
	FPI	10, 12	10, 12	10, 12	10, 12	10, 12	10, 12
	F.A., small (sq ft)	18.5	18.5	27.0	27.0	27.0	27.0
Hot water coils	Type—rows	5WH–1	5WH–1	5WH–1	5WH–1	5WH–1	5WH–1
	Type—rows	5WS–2	5WS–2	5WS–2	5WS–2	5WS–2	5WS–2
	FPI	9	9	9	9	9	9
	Face area (sq ft)	20.3	20.3	20.3	20.3	20.3	20.3
Steam coils	Type—rows	5JA–1	5JA–1	5JA–1	5JA–1	5JA–1	5JA–1
	FPI	6, 12	6, 12	6, 12	6, 12	6, 12	6, 12
	Face area (sq ft)	20.3	20.3	20.3	20.3	20.3	20.3
Gas furnace	Input (MBh)	250, 312, 400, 500, 625, 800, 812, 988, 1000, 1250					
	Nominal output (MBh)	200, 250, 320, 400, 500, 640, 650, 790, 800, 1000					
Electric heat	Nominal output (kW)	20, 40, 60, 80, 100, 120, 140, 160, 180, 200, 220, 240					
Panel filters	Type	85% (MERV 13) or 30% (MERV 7 or 8), pleated					
	Area (sq ft)	50.0	50.0	50.0	50.0	50.0	50.0
	Qty—size (in)	10–16×20×2 10–16×25×2	10–16×20×2 10–16×25×2	10–16×20×2 10–16×25×2	10–16×20×2 10–16×25×2	10–16×20×2 10–16×25×2	10–16×20×2 10–16×25×2
Prefilters (for cartridge filters)	Type	Prefilter, 30% (MERV 7 or 8), standard flow					
	Area (sq ft)	24.0	24.0	24.0	24.0	24.0	24.0
	Qty—size (in)	4–24×24×2 4–12×24×2	4–24×24×2 4–12×24×2	4–24×24×2 4–12×24×2	4–24×24×2 4–12×24×2	4–24×24×2 4–12×24×2	4–24×24×2 4–12×24×2
Cartridge filters	Type	65% (MERV 11) or 95% (MERV 14), standard flow					
	Area (sq ft)	24.0	24.0	24.0	24.0	24.0	24.0
	Qty—size (in)	4–24×24×12 4–12×24×12	4–24×24×12 4–12×24×12	4–24×24×12 4–12×24×12	4–24×24×12 4–12×24×12	4–24×24×12 4–12×24×12	4–24×24×12 4–12×24×12

1. Gas furnace size availability is limited by minimum airflow.
2. 460-volt capacities are shown. Electric heat availability is limited by minimum airflow.

Applied Rooftop Systems

Physical Data—RPS/RFS/RCS/RDT 045D through 079D

Data		Unit size						
		045D	050D/051D	062D/063D	068D	070D/071D	075D	079D
Compressor	Quantity—hp	4–10	4–11.5	4–13	4–15	6–10	6–11.5	3–11.5
	Capacity control	100-75-50-25-0				100-83-67-50-33-17-0		
Condenser fans	Qty—diameter (in)	4–26	4–26	6–26	6–26	6–26	8–26	8–26
Condenser fan motors	Qty—hp	4–1.0	4–1.0	6–1.0	6–1.0	6–1.0	8–1.0	8–1.0
RPS supply fans	Type	Forward curve, LP/MP						
	Qty—diameter (in)	1–27	1–27	1–27	1–27	1–27	8–26	8–26
	Motor hp range	3–50	3–50	3–50	3–50	3–50	8–1.0	8–1.0
	Type	DWDI airfoil						
	Qty—diameter (in)	1–27,30	1–27,30	1–30,33	1–30,33	1–30,33	8–26	8–26
RDT supply fans	Motor hp range	3–50	3–50	3–50	3–50	3–50	8–1.0	8–1.0
	Type	SWSI airfoil						
	Qty—diameter (in)	1–40,44	1–40,44	1–40,44	1–40,44	1–40,44	8–26	8–26
Return fans	Motor hp range	3–50	3–50	3–50	3–50	3–50	8–1.0	8–1.0
	Type	SWSI airfoil						
	Qty—diameter (in)	1–40	1–40	1–40	1–40	1–40	1–40	1–40
Exhaust fans	Motor hp range	2–30	2–30	2–30	2–30	2–30	2–30	2–30
	Type	Propeller						
	Diameter (in)	36	36	36	36	36	36	36
	Quantity	1 or 2 per unit	1 or 2 per unit	1 or 2 per unit	1 or 2 per unit	1 or 2 per unit	1 or 2 per unit	1 or 2 per unit
Evaporator coils	Motor hp	5 each	5 each	5 each	5 each	5 each	5 each	5 each
	Rows	4, 5	4, 5	4, 5	4, 5	4, 5	4, 5	4, 5
	FPI	10, 12	10, 12	10, 12	10, 12	10, 12	10, 12	10, 12
	F.A., small (sq ft)	39.5	39.5	39.5	39.5	39.5	39.5	39.5
	F.A., large (sq ft)	47.1	47.1	47.1	47.1	47.1	47.1	47.1
Hot Water coils	Type—rows	5WH–1	5WH–1	5WH–1	5WH–1	5WH–1	5WH–1	5WH–1
		5WS–2	5WS–2	5WS–2	5WS–2	5WS–2	5WS–2	5WS–2
	FPI	9	9	9	9	9	9	9
	Face area (sq ft)	29.7	29.7	29.7	29.7	29.7	29.7	29.7
Steam coils	Type—rows	5JA–1, 2	5JA–1, 2	5JA–1, 2	5JA–1, 2	5JA–1, 2	5JA–1, 2	5JA–1, 2
	FPI	6, 12	6, 12	6, 12	6, 12	6, 12	6, 12	6, 12
	Face area (sq ft)	29.7	29.7	29.7	29.7	29.7	29.7	29.7
Gas furnace	Input (MBh)	250, 312, 400, 500, 625, 800, 812, 988, 1000, 1250						
	Nom. output (MBh)	200, 250, 320, 400, 500, 640, 650, 790, 800, 1000						
Electric heat	Nom. output (kW)	40, 60, 80, 100, 120, 160, 200, 240						
Panel filters	Type	85% (MERV 13) or 30% (MERV 7 or 8), pleated						
	Area (sq ft)	73.9	73.9	73.9	73.9	73.9	73.9	73.9
	Qty—size (in)	7–16x20x2 21–16x25x2	7–16x20x2 21–16x25x2	7–16x20x2 21–16x25x2	7–16x20x2 21–16x25x2	7–16x20x2 21–16x25x2	7–16x20x2 21–16x25x2	7–16x20x2 21–16x25x2
Prefilters (for cartridge filters)	Type	Prefilter, 30% (MERV 7 or 8), standard flow						
	Area (sq ft)	40.0	40.0	40.0	40.0	40.0	40.0	40.0
	Qty—size (in)	4–12x24x2 8–24x24x2	4–12x24x2 8–24x24x2	4–12x24x2 8–24x24x2	4–12x24x2 8–24x24x2	4–12x24x2 8–24x24x2	4–12x24x2 8–24x24x2	4–12x24x2 8–24x24x2
	Type	Prefilter, 30% (MERV 7 or 8), standard flow						
	Area (sq ft)	48.0	48.0	48.0	48.0	48.0	48.0	48.0
	Qty—size (in)	8–12x24x2	8–12x24x2	8–12x24x2	8–12x24x2	8–12x24x2	8–12x24x2	8–12x24x2
Cartridge filters	Type	65% (MERV 11) or 95% (MERV 14), standard flow						
	Area (sq ft)	40.0	40.0	40.0	40.0	40.0	40.0	40.0
	Qty—size (in)	4–12x24x12 8–24x24x12	4–12x24x12 8–24x24x12	4–12x24x12 8–24x24x12	4–12x24x12 8–24x24x12	4–12x24x12 8–24x24x12	4–12x24x12 8–24x24x12	4–12x24x12 8–24x24x12
	Type	65% (MERV 11) or 95% (MERV 14), standard flow						
	Area (sq ft)	48.0	48.0	48.0	48.0	48.0	48.0	48.0
	Qty—size (in)	8–12x24x12	8–12x24x12	8–12x24x12	8–12x24x12	8–12x24x12	8–12x24x12	8–12x24x12

1. Gas furnace size availability is limited by minimum airflow (RFS/RPS only).

2. 460-volt capacities are shown. Electric heat availability is limited by minimum airflow (RFS/RPS only).

Applied Rooftop Systems

Physical Data—RPS/RFS/RCS/RDT 080D through 105D

Data		Unit size				
		080D/081D	085D	090D/091D	100D/101D	105D
Compressor	Quantity—hp	6–11.5	6–13	6–13	3–13 3–15	6–15
	Capacity control	100-83-67-50-33-17-0			100-83-67-49-33-16-0	100-84-67-50-33-17-0
Condenser fans	Qty—diameter (in)	6–26	6–26	8–26	9–26	8–26
Condenser fan motors	Qty—hp	6–1.0	6–1.0	8–1.0	9–1.0	8–1.0
Supply fans	Type	DWDI airfoil				
	Qty—diameter (in)	1–33, 36	1–33, 36	1–33, 36	1–36, 40	1–36, 40
	Motor hp range	5–75	5–75	5–75	5–75	5–75
Return fans	Type	SWSI airfoil				
	Qty—diameter (in)	1–44.5	1–44.5	1–44.5	1–44.5	1–44.5
	Motor hp range	5–60	5–60	5–60	5–60	5–60
Exhaust fans	Type	Propeller				
	Diameter (in)	36	36	36	36	36
	Quantity	1–3 per unit	1–3 per unit	1–3 per unit	1–3 per unit	1–3 per unit
	Motor hp	5 each	5 each	5 each	5 each	5 each
Evaporator coils	Rows	4, 5	4, 5	4, 5	4, 5	4, 5
	FPI	10, 12	10, 12	10, 12	10, 12	10, 12
	F.A., small (sq ft)	53.9	53.9	53.9	60.8	60.8
	F.A., large (sq ft)	60.8	60.8	60.8	76.0	76.0
Hot Water coils	Type—rows	5WH–1 5WS–2	5WH–1 5WS–2	5WH–1 5WS–2	5WH–1 5WS–2	5WH–1 5WS–2
	FPI	9	9	9	9	9
	Face area (sq ft)	42.2	42.2	42.2	42.2	42.2
	Type—rows	5JA–1, 2	5JA–1, 2	5JA–1, 2	5JA–1, 2	5JA–1, 2
Steam coils	FPI	6, 12	6, 12	6, 12	6, 12	6, 12
	Face area (sq ft)	42.2	42.2	42.2	42.2	42.2
	Type—rows	5JA–1, 2	5JA–1, 2	5JA–1, 2	5JA–1, 2	5JA–1, 2
Gas furnace	Input (MBh)	625, 800, 812, 988, 1000, 1250, 1375, 1750, 1875, 2500				
	Nom. output (MBh)	500, 640, 650, 790, 800, 1000, 1100, 1400, 1500, 2000				
Electric heat	Nom. output (kW)	80, 100, 120, 160, 200, 240, 280, 320				
Panel filters	Type	85% (MERV 13) or 30% (MERV 7 or 8), pleated				
	Area (sq ft)	116.1	116.1	116.1	116.1	116.1
	Qty—size (in)	11–16x20x2 33–16x25x2	11–16x20x2 33–16x25x2	11–16x20x2 33–16x25x2	11–16x20x2 33–16x25x2	11–16x20x2 33–16x25x2
Prefilters (for cartridge filters)	Type	Prefilter, 30% (MERV 7 or 8), standard flow				
	Area (sq ft)	56.0	56.0	56.0	64.0	64.0
	Qty—size (in)	4–12x24x2 12–24x24x2	4–12x24x2 12–24x24x2	4–12x24x2 12–24x24x2	16–24x24x2	16–24x24x2
	Type	Prefilter, 30% (MERV 7 or 8), standard flow				
	Area (sq ft)	64.0	64.0	64.0	80.0	80.0
	Qty—size (in)	16–24x24x2	16–24x24x2	16–24x24x2	8–12x24x2 16–24x24x2	8–12x24x2 16–24x24x2
Cartridge filters	Type	65% (MERV 11) or 95% (MERV 14), standard flow				
	Area (sq ft)	56.0	56.0	56.0	64.0	64.0
	Qty—size (in)	4–12x24x12 12–24x24x12	4–12x24x12 12–24x24x12	4–12x24x12 12–24x24x12	16–24x24x12	16–24x24x12
	Type	65% (MERV 11) or 95% (MERV 14), standard flow				
	Area (sq ft)	64.0	64.0	56.0	80.0	80.0
	Qty—size (in)	16–24x24x12	16–24x24x12	16–24x24x12	8–12x24x12 16–24x24x12	8–12x24x12 16–24x24x12

1. Gas furnace size availability is limited by minimum airflow (RFS/RPS only).
2. 460-volt capacities are shown. Electric heat availability is limited by minimum airflow (RFS/RPS only).

Applied Rooftop Systems

Physical Data—RPS/RFS/RCS/RDT 110D through 140D

Data		Unit size				
		110D	120D	125D	130D	140D
Compressor	Quantity—hp	6–15	3–15 3–20	6–20	6–20	3–20 3–25
	Std. capacity control	100-84-67-50-33-17-0	100-83-67-49-33-16-0	100-84-67-50-33-17-0		100-83-67-49-33-16-0
Condenser fans	Qty—diameter (in)	8–26	9–26	10–26	12–26	12–26
Condenser fan motors	Qty—hp	8–1.0	9–1.0	10–1.0	12–1.0	12–1.0
Supply fans	Type	DWDI airfoil				
	Qty—diameter (in)	1–36, 40	1–36, 40	1–36, 40	1–36, 40	1–36, 40
	Motor hp range	5–75	5–75	5–75	5–75	5–75
Return fans	Type	SWSI airfoil				
	Qty—diameter (in)	1–44.5	1–44.5	1–44.5	1–44.5	1–44.5
	Motor hp range	5–60	5–60	5–60	5–60	5–60
Exhaust fans	Type	Propeller				
	Diameter (in)	36	36	36	36	36
	Quantity	1–3 per unit	1–3 per unit	1–3 per unit	1–3 per unit	1–3 per unit
	Motor hp	5 each	5 each	5 each	5 each	5 each
Evaporator coils	Rows	4, 5	4, 5	4, 5	4, 5	4, 5
	FPI	10, 12	10, 12	10, 12	10, 12	10, 12
	F.A., small (sq ft)	60.8	60.8	–	–	–
	F.A., large (sq ft)	76.0	76.0	76.0	76.0	76.0
Hot water coils	Type—rows	5WH–1 5WS–2	5WH–1 5WS–2	5WH–1 5WS–2	5WH–1 5WS–2	5WH–1 5WS–2
	FPI	9	9	9	9	9
	Face area (sq ft)	42.2	42.2	42.2	42.2	42.2
	Type—rows	5JA–1, 2	5JA–1, 2	5JA–1, 2	5JA–1, 2	5JA–1, 2
Steam coils	FPI	6, 12	6, 12	6, 12	6, 12	6, 12
	Face area (sq ft)	42.2	42.2	42.2	42.2	42.2
	Type—rows	5JA–1, 2	5JA–1, 2	5JA–1, 2	5JA–1, 2	5JA–1, 2
Gas furnace	Input (MBh)	625, 800, 812, 988, 1000, 1250, 1375, 1750, 1875, 2500				
	Nom. output (MBh)	500, 640, 650, 790, 800, 1000, 1100, 1400, 1500, 2000				
Electric heat	Nom. output (kW)	80, 100, 120, 160, 200, 240, 280, 320				
Panel filters	Type	85% (MERV 13) or 30% (MERV 7 or 8), pleated				
	Area (sq ft)	116.1	116.1	116.1	116.1	116.1
	Qty—size (in)	11–16x20x2 33–16x25x2	11–16x20x2 33–16x25x2	11–16x20x2 33–16x25x2	11–16x20x2 33–16x25x2	11–16x20x2 33–16x25x2
Prefilters (for cartridge filters)	Type	Prefilter, 30% (MERV 7 or 8), standard flow				
	Area (sq ft)	64.0	64.0	64.0	64.0	64.0
	Qty—size (in)	4–12x24x2 12–24x24x2	4–12x24x2 12–24x24x2	16–24x24x2	16–24x24x2	16–24x24x2
	Type	Prefilter, 30% (MERV 7 or 8), standard flow				
	Area (sq ft)	80.0	80.0	80.0	80.0	80.0
	Qty—size (in)	8–12x24x2 16–24x24x2	8–12x24x2 16–24x24x2	8–12x24x2 16–24x24x2	8–12x24x2 16–24x24x2	8–12x24x2 16–24x24x2
Cartridge filters	Type	65% (MERV 11) or 95% (MERV 14), standard flow				
	Area (sq ft)	64.0	64.0	64.0	64.0	64.0
	Qty—size (in)	16–24x24x12	16–24x24x12	16–24x24x12	16–24x24x12	16–24x24x12
	Type	65% (MERV 11) or 95% (MERV 14), standard flow				
	Area (sq ft)	80.0	80.0	80.0	80.0	80.0
	Qty—size (in)	8–12x24x12 16–24x24x12	8–12x24x12 16–24x24x12	8–12x24x12 16–24x24x12	8–12x24x12 16–24x24x12	8–12x24x12 16–24x24x12

1. Gas furnace size availability is limited by minimum airflow (RFS/RPS only).

2. 460-volt capacities are shown. Electric heat availability is limited by minimum airflow (RFS/RPS only).

RoofPak™ Models RPE and RDE Singlezone Heating and Cooling Units—75 to 150 Tons



Model RPE/RDE—75 to 150 tons

Features

- Seven sizes from 75 to 150 tons
- Blow-through (model RPE) or draw-through (model RDE) cooling
- Walk-in service vestibule contains water connections, controls, water treatment and refrigerant service components
- R-407C refrigerant

Benefits

- Up to 40% savings in condensing unit energy consumption versus air-cooled alternatives
- Reduced peak electrical demand at design conditions allows unit electrical service to be downsized for lower installation costs and electrical demand charges
- R-407C is an HFC refrigerant with good efficiency on evaporative cooled applications

Typical savings vs. air-cooled rooftop systems*

To illustrate the savings generated by evaporative condensing, consider a two-story shopping mall using several 125-ton VAV rooftop units, occupied 365 days

a year. The table below shows the Daikin RPE condensing unit savings if the mall is located in Los Angeles, New York and Las Vegas.

Conditions	Los Angeles		New York		Las Vegas		
	Air-cooled	Daikin RPE	Air-cooled	Daikin RPE	Air-cooled	Daikin RPE	
Design ambient dry bulb/wet bulb	95°F/72°F	95°F / 72°F	95°F / 75°F	95°F / 75°F	110°F / 72°F	110°F / 72°F	
Electrical consumption rate (per kW hour)	\$0.15	\$0.15	\$0.11	\$0.11	\$0.07	\$0.07	
Electrical demand rate (per kW hour)	\$24.00	\$24.00	\$18.00	\$18.00	\$8.00	\$8.00	
Condensing unit	Efficiency (kW/ton)	1.15	0.85	1.15	0.88	1.40	0.85
	Electrical cost	\$30,200	\$22,100	\$17,860	\$12,375	\$19,042	\$11,351
	Percent savings	27%		31%		40%	

* All energy analysis comparison charts are estimates and have been generated using Energy Analyzer™ software. Actual customer results may vary. For more information on Energy Analyzer software, see page 7.

RoofPak Models RPE and RDE Singlezone Heating and Cooling Units Features and Options

- 1 Stainless steel fan decks with severe duty motors and corrosion-resistant fans
- 2 PVC spray tubes
- 3 Stainless steel spray enclosure
- 4 Polymer tube sheets
- 5 Copper tube bundles
- 6 Replaceable nozzles with 150° spray arc
- 7 Easy compressor access
- 8 Replaceable stainless steel sump
- 9 Walk-in service compartment
- 10 Access doors on both sides

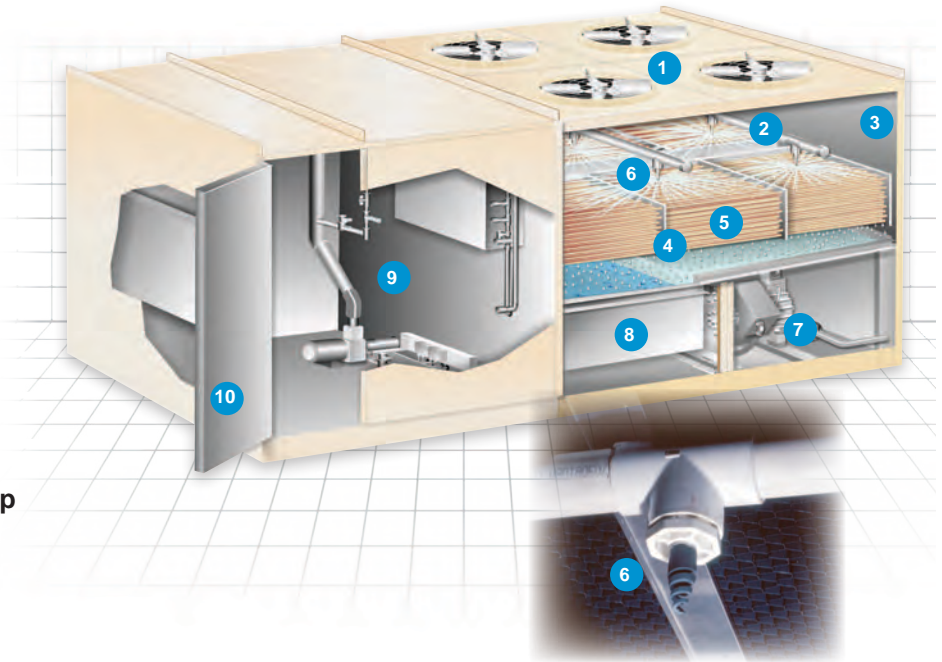

Replaceable nozzles with 150° spray arc



Optional non-chemical water treatment

- Eliminates the costs and hazards associated with chemical water treatment
- Reduces water consumption and possibly eliminates sanitary sewer costs of blowdown water
- Evaporative condenser maintenance does not exceed maintenance for air-cooled units

Physical Data—RPS/RFS/RCS/RDT 110D through 140D

Data		Unit size						
		076C	089C	100C	110C	130C	140C	150C
Nominal capacity (tons) ¹		79.2	89.4	98.9	119.3	130.8	141.9	152.5
Nominal airflow (cfm)		32,000	35,000	35,000	42,000	45,000	46,000	46,000
Compressor	Type	Reciprocating						
	Quantity – hp	2 – 30	2 – 35	2 – 40	4 – 25	4 – 30	2 – 30, 2 – 35	4 – 35
	Std. capacity control	100-83-67-33-0		100-75-50-25-0		100-72-44-22-0		100-75-50-25-0
	Opt. capacity control	100-83-67-50-33-16-0		100-88-75-63-50-38-25-12-0		100-89-79-61-44-32-22-11-0		100-92-83-67-50-42-33-16-0
Condenser fans	Qty – diameter (in)	4 – 26	4 – 26	4 – 26	6 – 26	6 – 26	6 – 26	6 – 26
Condenser fan motors	Qty – hp	4 – 1.5	4 – 1.5	4 – 1.5	6 – 1.5	6 – 1.5	6 – 1.5	6 – 1.5

Refer to RPS and RDT tables for additional physical data.

1. Rated in accordance with AHRI Standard 360.

Coils

Water Cooling or Heating, Evaporator and Steam—Fin Types HI-F5, HI-F8 and E-F5

- Easy selection of the widest variety of coil options
- Over 70 years of experience setting the industry standard for quality
- High efficiency, maximum heat transfer design
- Quick shipping programs
- Flexibility and manufacturing capabilities for special materials and configurations required for industrial and process applications
- Optional coil connection lengths and arrangements available
- Flange dimensions are variable to fit your application

For more detail, refer to Catalogs 411 (Water Cooling & Evaporator), 412 (Water Heating), and 413 (Steam).

For the most current information, refer to DaikinApplied.com.



Water cooling or heating coils

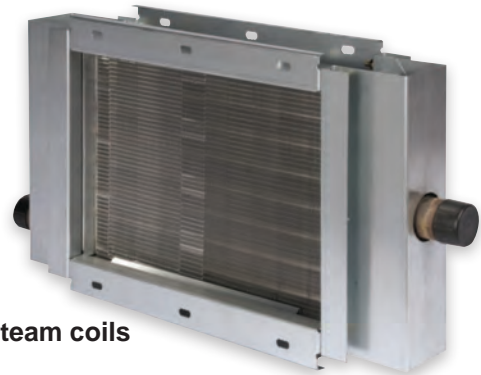

Steam coils

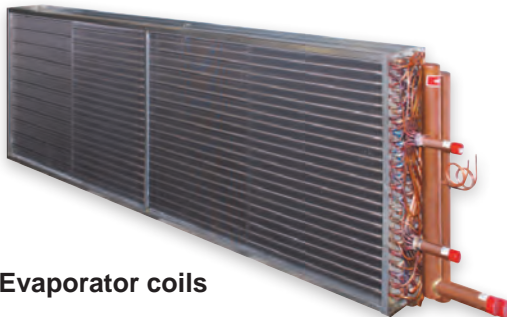

Evaporator coils



Reclaiming and Condenser coils

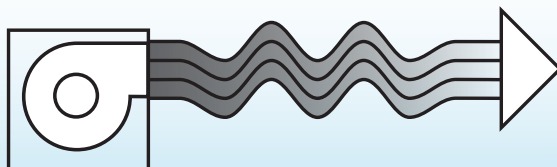

HI-F high efficiency fin type

Maximum heat transfer due to continuous air turbulence across the fin surface

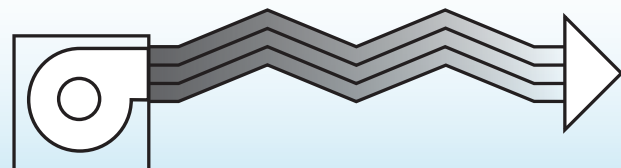

E-F energy efficient fin type

- Energy saving
- Reduces air pressure drop by as much as 33%
- Fan brake horsepower requirements are lower

Water Cooling and Evaporator Coils—Types HI-F5 and E-F5

Chilled Water Coil Circuitings

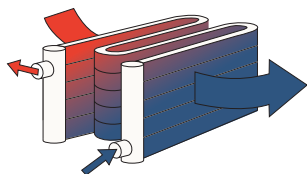

- Six standard serpentine circuitings
- Counterflow water circuits
- Unique or universal hand of connection available (all cooling coils)

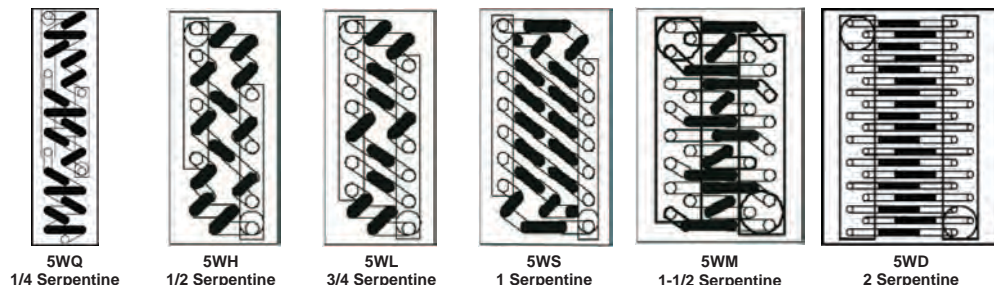

Evaporator Coil Circuitings

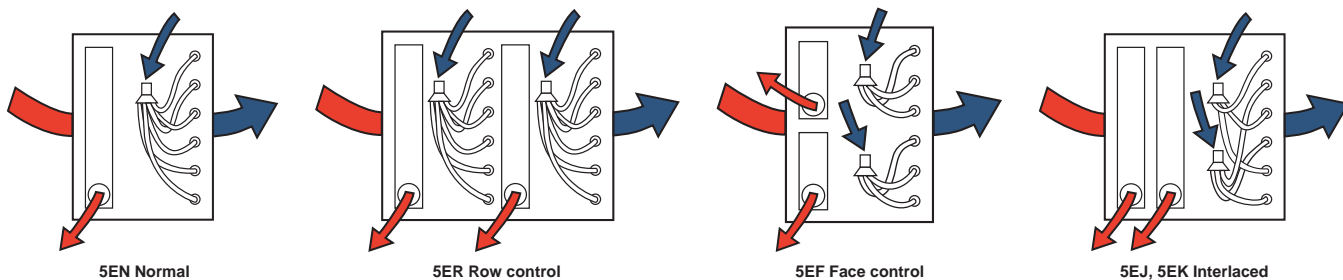

Standard Availability Chart—Water Cooling and Evaporator Coils

Coil type		Chilled water						Evaporator					
Coil model		5MH	5MS	5WH	5WL	5WS	5WM	5WD	5EN	5EF	5ER	5EJ	5EK
Serpentine circuit		1/2	1	1/2	3/4	1	1-1/2	2	Normal	Face	Row	Interlaced	
Rows		2		3,4,5,6 8,10,12			4,5,6 8,10,12	4,6,8 10,12	2,3,4,5 6,8,10		6	3,4,6,8	4,8
Connection location		Same end except 5WS 3,5 row; 5WD 6,10 row						Same end					
Fin height 3" increment		12" to 54"						12" to 54"			15" to 54"		
Fin length 0.10" increment		12" to 216"						12" to 161" (up to 216" with manufacturing approval)					
Fin spacing (FPI)		6 to 14						6 to 14					
Fins	Fin type	HI-F	•	•	•	•	•	•	•	•	•	•	•
		E-F	•	•	•	•	•	•	•	•	•	•	•
	Aluminum	.0075	•	•	•	•	•	•	•	•	•	•	•
		.0095	•	•	•	•	•	•	•	•	•	•	•
	Copper	.006	•	•	•	•	•	•	•	•	•	•	•
		.0075	•	•	•	•	•	•	•	•	•	•	•
Tubing	Copper	.0095	•	•	•	•	•	•	•	•	•	•	•
		.020 ¹	•	•	•	•	•	•	•	•	•	•	•
		.025	•	•	•	•	•	•	•	•	•	•	•
		.035	•	•	•	•	•	•	•	•	•	•	•
		.049	•	•	•	•	•	•	•	•	•	•	•
Tubing diameter		5/8"						5/8"					
Tubing face C/C		1.5						1.5					
Headers standard mat ^{l2}		Copper tubing						Copper tubing					
Maximum std. operating limits	P	250 psig						250 psig					
	T	300°F						300°F					

• Feature available
 1. 0.020 is a nominal tube thickness.
 2. Optional header materials are available. Consult your local Daikin Sales Representative.

Coils

Water Heating Coils—Types HI-F5 and E-F5

Hot Water Coil Circuitings

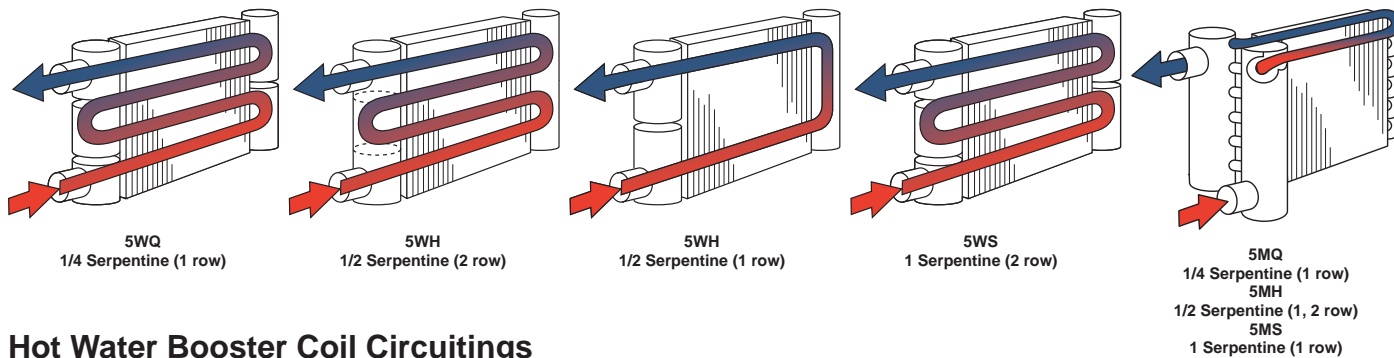

Hot Water Booster Coil Circuitings

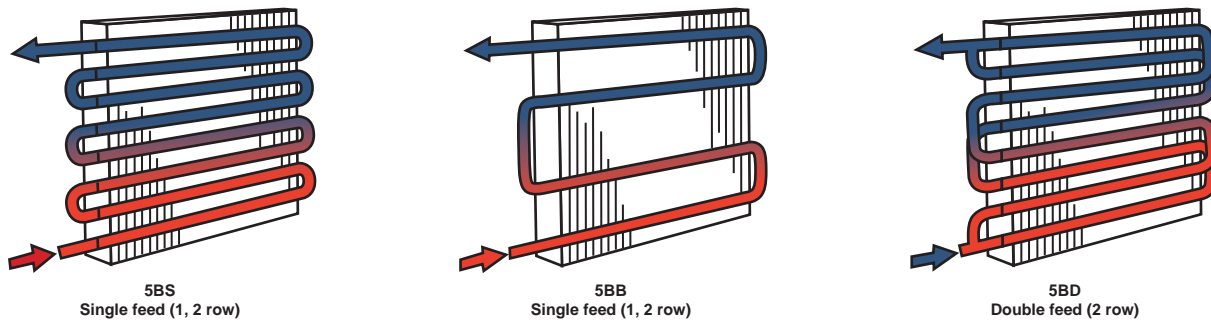

Standard Availability Chart—Water Cooling and Evaporator Coils

Coil type		Hot water										Cleanable hot water (removable plug)									Hot water (booster)						
Coil model		5MQ	5MH	5MS	5WB	5WQ	5WH	5WL	5WS	5WM	5WD	5KQ	5KH	5KS	5QQ	5QH	5QS	5PQ	5PH	5PS	5BB	5BS	5BD				
Serpentine circuit		1/4	1/2	1	11	1/4	1/2	3/4	1	1-1/2	2	1/4	1/2	1	1/4	1/2	1	1/4	1/2	1	1 feed	1 feed	1 feed				
Rows		1	1,2	2	1,2	1	1,2,3,4	3,4	2,3,4	4	4	1	1,2	2	1	1,2	2	1	1,2	2	1,2	1,2	2				
Connection location		Same end except 5WS 3-row										Same end									Same end						
Fin height 3" increment		48" to 54" ^{1,3}		45" to 54"		12" to 42" (1 & 2 row) & 12-54 (3 & 4 row)										12" to 42"									6" to 24"		
Fin length 0.10" increment		12" to 216"										12" to 216"									6" to 60"						
Fin spacing (FPI)		6 to 14										6 to 14									6 to 14						
Fins	Fin type	HI-F	•	•	•	•	•	•	•	•	•	•	•	•	•	•	•	•	•	•	•	•	•				
		E-F	•	•	•	•	•	•	•	•	•	•	•	•	•	•	•	•	•	•	•	•	•				
	Aluminum	.0075	•	•	•	•	•	•	•	•	•	•	•	•	•	•	•	•	•	•	•	•	•				
		.0095	•	•	•	•	•	•	•	•	•	•	•	•	•	•	•	•	•	•	•	•	•				
	Copper	.006	•	•	•	•	•	•	•	•	•	•	•	•	•	•	•	•	•	•	•	•	•				
		.0075	•	•	•	•	•	•	•	•	•	•	•	•	•	•	•	•	•	•	•	•	•				
Tubing	Copper	.020 ¹	•	•	•	•	•	•	•	•	•	•	•	•	•	•	•	•	•	•	•	•	•				
		.025	•	•	•	•	•	•	•	•	•	•	•	•	•	•	•	•	•	•	•	•	•				
		.035	•	•	•	•	•	•	•	•	•	•	•	•	•	•	•	•	•	•	•	•	•				
		.049	•	•	•	•	•	•	•	•	•	•	•	•	•	•	•	•	•	•	•	•	•				
Tubing diameter		5/8"										5/8"									5/8"						
Tubing face C/C		1.5		3.0		1.5										1.5									3.0		1.5
Headers standard mat ²		Copper tubing										Copper tubing									Threaded copper fittings						
Maximum std. operating limits		P	250 psig										250 psig									250 psig					
		T	300°F										300°F									300°F					

• Feature available
 1. 0.020 is a nominal tube thickness.
 2. Optional header materials are available. Consult your local Daikin Sales Representative.

Coils

Steam Coils—Types HI-F5 and E-F5

Steam Coil Circuitings

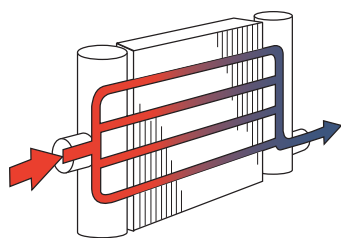

5S, 5H
Single tube

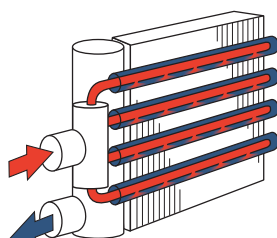

5J, 5G, 8J, 8G
Distributing tube
(same end connections)

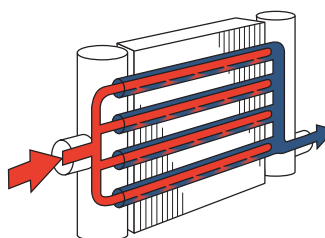

8R, 8T
Distributing tube
(opposite end connections)

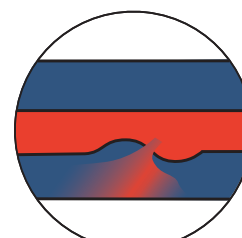

Directional orifice
(distributing tube
steam coils)

Standard Availability Chart—Steam Coils

Coil type		Steam (single tube)		Steam (distributing tube)						
Coil model		5SA	5HA	5JA	5GA	8JA	8GA	8RA	8TA	
Serpentine circuit		Does not apply		Does not apply						
Rows		1,2		1,2		1				
Connection location		Opposite end		Same end		Same end		Opposite end		
Fin height, 3" increment		12" to 42"								
Fin length, 0.10" increment		12" to 129"								
Fin spacing (FPI)		6 to 14				3 to 14				
Fins	Fin type	HI-F	•	•	•	•	•	•	•	
		E-F	•	•	•	•				
	Aluminum	.0075	•	•	•	•				
		.0095	•	•	•	•	•*	•*	•*	•*
		.0120					•		•	
	Copper	.006	•	•	•	•				
.0075		•	•	•	•	•*	•*	•*	•*	
.0095		•	•	•	•	•*	•*	•*	•*	
Tubing	Copper	.020 ¹	•	•	•					
		.025	•	•	•	•		•		
		.035	•	•	•					
		.049	•	•	•	•		•		
	Cupro-nickel	.020		•		•				
		.035		•		•		•		•
		.049		•		•		•		•
Tubing diameter		5/8"		5/8"		1"				
Tubing face C/C		1.5		1.5		3.0				
Headers standard material		Copper	Cu Ni	Copper	Cu Ni	Copper	Cu Ni	Copper	Cu Ni	
Maximum standard operating limits	P	150 psig	350 psig	150 psig	350 psig	150 psig	350 psig	150 psig	350 psig	
	T	366°F	450°F	366°F	450°F	366°F	450°F	366°F	450°F	

• Feature available.
* Requires 6 fins per inch or more.
1. 0.020 is a nominal tube thickness.

Custom Air Handling Products—900 to 129,000 cfm

- High static, low leakage - ASHRAE 111 Class 6 (0.27 cfm per ft² at +/-8" cabinet pressure)
- Energy recovery wheel for 100% outdoor air or economizer configurations
- Unlimited configuration and footprint flexibility
- Extensive coil selections - cooling, heating, steam, and evaporator coils
- Single/dual direct-drive, single/dual belt drive, or fan array options
- Advance filter options - low pressure, gas phase, HEPA, or PCO
- UV lights/anti-microbial protection liner options for improved IAQ

For more detail, refer to A/SP 31-359.

For the most current information, refer to DaikinApplied.com.

Custom Air Handler—900 to 129,000 cfm

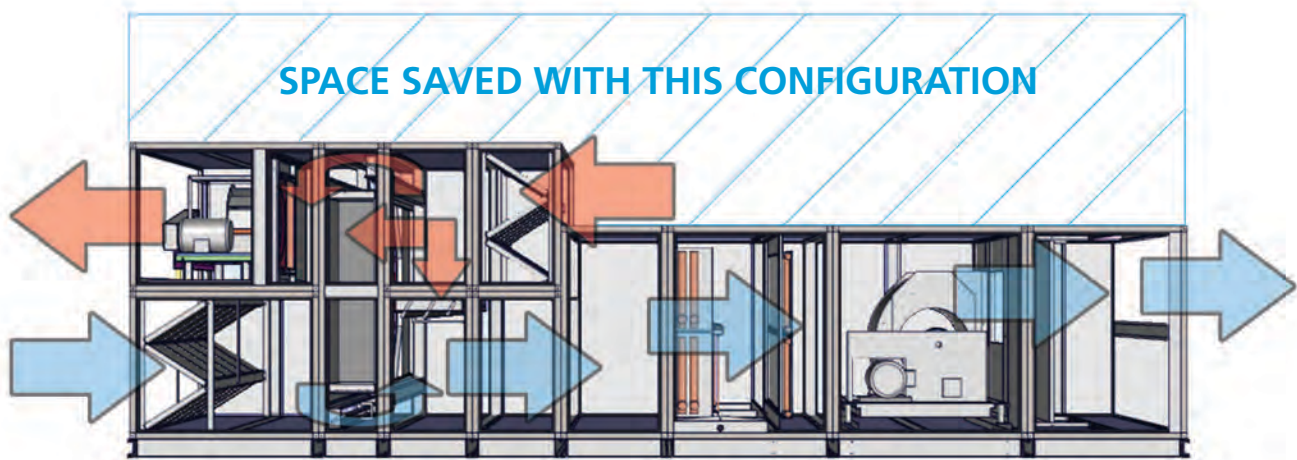

Mixed Cabinetry Configuration with Energy Recovery Wheel

Application Solutions with Custom Components

Superior cabinet construction

- High static, low ASHRAE 111 Class 6 leakage (0.27 cfm per ft² at +/-8" cabinet pressure)
- OSHPOD and IBC
- Stainless steel or aluminum liner
- Varying steel gauge thicknesses
- Double wall, R-13 foam-injected panels
- Galvanized or pre-painted steel finishes.
- Welded gasketed frame channels and high pressure panels, doors, handles, and seals



2" variable dimensioning

- Provides tremendous component width/height sizing flexibility

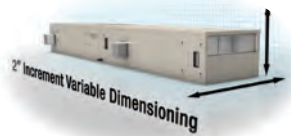

Configuration options

- Unlimited configuration and footprint flexibility
- Side-by-side configuration for height limitations
- Stacked configuration for width limitations



Stacked Configuration



Side-by-Side Configuration

Modular designed sections

- Sections easily pass through narrow halls and doorways
- Patented splice collar design lowers installation costs
- Ideal for retrofit applications



Splice Collar

Fan options

- Maximize footprint design
- Sound attenuating walls option for low decibel operation
- Single/dual belt-drive
- Single/dual direct drive fans
- Fan array for redundancy and easy maintenance



Dual Fan

Fan Array

Advanced filter options

- Low Pressure Filters - 2" and 4" angular or flat, cartridge, or bag
- Gas Phase Filters - gas media or blended media for broad spectrum filtration
- HEPA Filters - remove 99.97% of all particles greater than 0.3 micrometer from air path.
- PCO Filters - titanium oxide coated filters to render contaminants harmless

Extensive coil selections

- Cooling, heating, steam, and evaporator coils
- Extended coil connections and gasketed air seals provide energy savings, high-efficiencies, and maximum heating/cooling transfer
- Aluminum, copper, or electro-coating options
- Wide range of tube/fin thicknesses and circuiting for high-quality performance

UV lights/anti-microbial protection liner options

- Logical, cost effective additions for care facilities where ambient conditions routinely involve high humidity levels,
- Improves IAQ by diminishing surface mold, bacteria and associated toxins

Energy recovery wheel

- AHRI certified component
- Cost-effective and efficient
- Meets ASHRAE 62.1 ventilation requirements
- Recovers both heat and moisture energy
- Factory-installed and tested
- 100% outdoor air or economizer configurations



Access and service vestibules

- Maintenance friendly access and service vestibules
- Aluminum diamond treadplates for added corrosion resistance and increased traction

Tempered round windows

- Factory-installed tempered Plexiglas windows
- Strongest and tightest seal available
- Ideal for high static/low leakage applications



Inward swinging doors/inside door handles

- Perfect for positive pressure sections
- Easy serviceability

Roller cam door handles

- Ideal for high filtration units operating at extreme pressures
- Minimize air leakage



Outdoor Air Handling Product Summary Chart

Model:

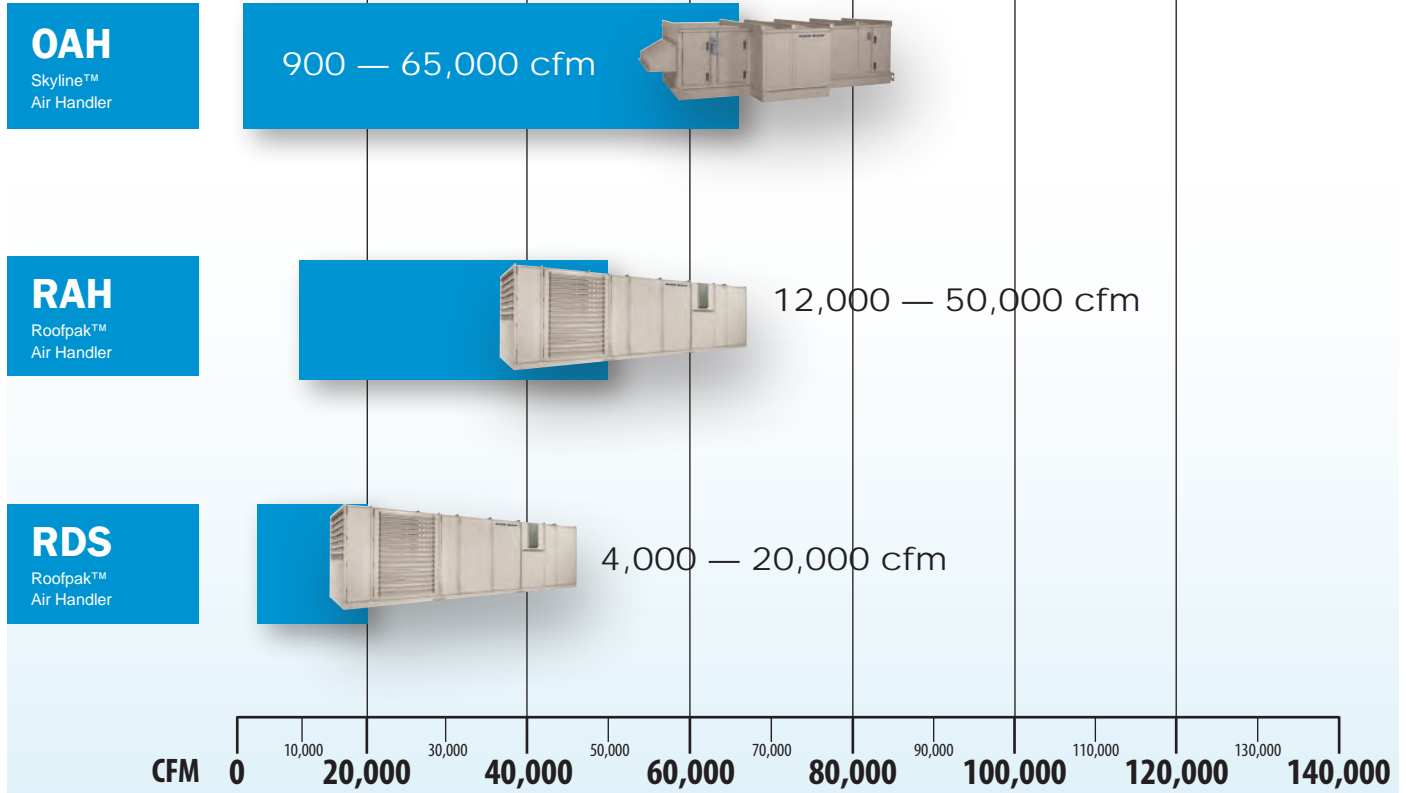

Skyline™ Outdoor Air Handlers, 3 to 92 ft²—900 to 65,000 cfm

- Flexibility—custom modular platform and multiple component options
- Operating efficiency—efficient fan selections
- Easy, low cost installation—ships assembled or by section with curb-ready base rail and heavy duty lifting lugs; optional roof curb kit with variable heights
- Easy maintenance and serviceability—easy-to-remove access panels
- Indoor air quality—low leakage cabinet and double-sloped drain pan

For more detail, refer to Catalog 570.

For the most current information, refer to DaikinApplied.com.



Model OAH—900 to 65,000 cfm

Skyline Model OAH and OAC Air Handlers Features and Options

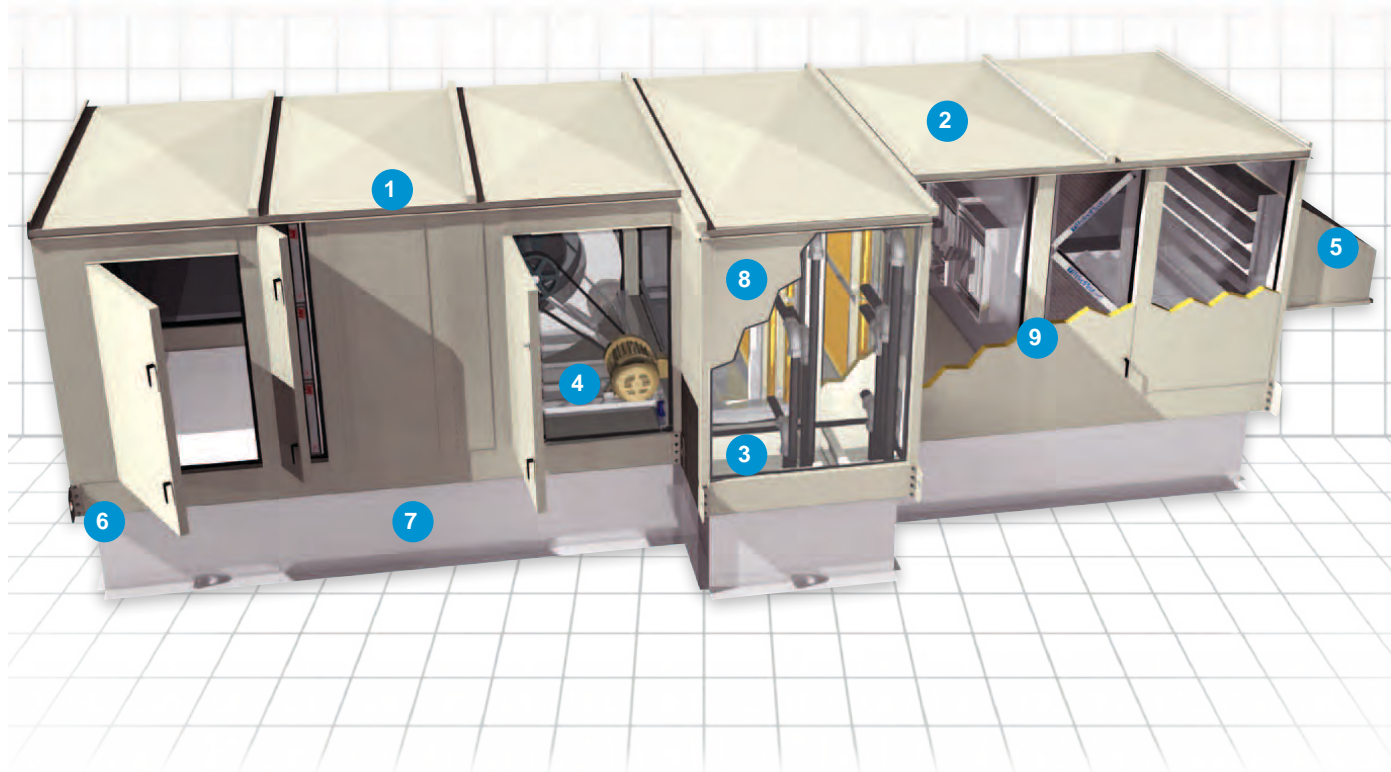

1 Durable, weather tight cabinet

- Cross-broken top panels eliminate standing water
- Standing "C" cap over joint provides a watertight seal
- Drip shield on all sides and over doors
- Pre-painted frames and panels
- R-13 foam-injected insulation
- Stainless steel liners option

2 Custom modular design

- Allows custom selection and configuration of components to meet performance requirements

3 Visible double-sloped drain pan

- Microbial-resistant coated galvanized or optional stainless steel to inhibit bacteria growth
- Makes inspection and cleaning easier
- Improves IAQ

4 Motor control

- Disconnect switches: non-fused, fused, circuit breaker
- Starters: IEC and NEMA type
- VFDs: Daikin, ABB, Danfoss

5 Damper hoods (optional) with screens

- Direct rain or snow away from required openings

6 Heavy duty base rail

- Standard base rail in varying heights (4" to 12") or curb-ready design, forms weather tight seal
- Lifting lugs on all four corners facilitates easy rigging

7 Factory-supplied roof curb (optional)

- Designed specifically to match custom-modular design flexibility
- Variable heights from 16" to 30" to meet installation requirements
- Includes separate pipe chase

8 Piping vestibule

- Encloses piping connections within unit cabinet
- Variable depths to meet your piping requirement

9 Patented gasketed frame channels and R-13 foam-injected panels

- Eliminates metal-to-metal contact between paneling and framework to minimize air leakage
- Provides superior strength
- Promotes high IAQ and long life

Skyline Outdoor Air Handlers Options

Use Daikin Skyline as a product platform on which to build the ideal outdoor air handler for your specific application. Options include:

- Curb-ready base and roof curb kits (16", 20", 24", 30")
- Multiple sizes of insulated, double-wall coil and piping vestibules
- Horizontal or vertical integral face and bypass dampers
- Hoods and grilles for damper openings
- Variable Dimensioning™ on 2" increments
- Multiple coil face areas per unit size
- Disconnects/starters and VFD's
- Multiple section depths
- Various casing and drain pan materials
- Mixing boxes/economizers
- Sound attenuators
- Electro-Fin epoxy coil coating
- Multiple coil section depths
- Humidifier manifold
- IBC seismic certification
- Gas-phase filtration
- Miami-Dade hurricane certified
- Multiple fan selections: forward curve, airfoil, inline, and belt or direct drive plenum fans; twin fans (two forward curved fans on one shaft)
- Dual direct-drive fans for redundancy
- Filters (flat, angular, bag and cartridge) available in side load and/or front loading configurations
- Doors, marine lights, and receptacles
- Manual selections to accommodate special components
- Hinged access doors with full grip handles

RETURN / EXHAUST	ECONOMIZER	BLENDER	FILTER	F & BP DAMPER	COIL	ACCESS	HORIZONTAL COIL	SUPPLY FAN	DIFFUSER	COIL BLOW THRU	ACCESS	FILTER	ATTENUATOR	PLENUM
PLENUM FAN		2" & 4" ANGULAR	INTERNAL	HORIZ HEATING	LARGE	CLG. / HTG. COMBINATION	FC, AF FAN, & TWIN FAN		HORIZ	CARTRIDGE		DISCHARGE PLENUM		
FC, AF FAN & TWIN FAN	INLET PLENUM	2" & 4" FLAT	INTEGRAL	1 & 2 ROW STEAM AND 1-4 ROW WATER	MEDIUM	CLG. 10 ROW	PLENUM FAN		CLG. OR HTG.	BAG				
ESI FAN	MIXBOX WITH 4" FILTER	CARTRIDGE			SMALL	4 ROW	ESI FAN							
MIXING BOX	MIXBOX WITH 2" FILTER	BAG	RIGHT ANGLE			SFA COIL MFA COIL F & BP								
MIXBOX WITH ANG FILTER														

Commercial Outdoor Air Handling Products

Physical Data—Quick Select Table*—Skyline 003 through 021

Description	Unit size								
	003	004	006	008	010	012	014	017	021
Airflow range, cfm	900–2500	1200–3100	1700–4600	2200–6000	2900–7700	3600–9700	4200–11,200	5000–13,500	6000–16,000
cfm @ 500 ft/min through large face area coil	1550	1950	2850	3750	4800	6050	7000	8400	10050
Height x width, in	32 x 38	36 x 40	38 x 52	40 x 58	44 x 64	50 x 66	50 x 74	52 x 80	58 x 82
Cooling coil face area, sq.ft.									
Staggered large	3.9	4.8	6.6	8.5	10.7	13.5	15.4	18.3	21.9
Large	3.1	3.9	5.7	7.5	9.6	12.1	14	16.8	20.1
Staggered medium	2.6	3.4	4.7	6.4	8.3	9.8	11.2	13.7	17.2
Medium	2.1	2.8	4.1	5.6	7.4	8.8	10.2	12.6	15.8
Small	NA	2.3	3.3	4.7	6.4	7.7	8.9	11.2	14.4
Fan section—depth, in									
Largest housed fan avail. w/ top hor. dis.	32	32	36	40	40	46	46	50	52
Largest inline fan and motor available	N/A	N/A	N/A	N/A	N/A	44	44	48	54
Largest belt drive plenum fan available	N/A	N/A	N/A	N/A	34	42	42	48	52
Largest direct drive plenum fan available	N/A	N/A	N/A	44	46	56	56	66	68
Largest twin fan and motor available	N/A	N/A	N/A	50	54	56	58	58	66
Largest 1 x 3 fan array and motor available	N/A	N/A	N/A	N/A	N/A	N/A	N/A	40	40
Largest 2 x 2 fan array and motor available	N/A	N/A	N/A	N/A	N/A	N/A	N/A	N/A	40
Largest 2 x 3 fan array and motor available	N/A	N/A	N/A	N/A	N/A	N/A	N/A	N/A	40
Mixing box—depth, in									
Mixing box only	20	20	20	20	22	24	24	26	30
Mixing box with flat filter	24	24	24	24	26	28	28	30	34
Mixing box with angular filter	42	42	42	42	44	46	46	48	52
Economizer—depth, in									
Depth	66	66	70	66	74	72	77	80	84
Blender—depth, in									
Largest Kees	18	20	24	26	28	34	36	38	42
Largest Blender Products IV	18	22	26	30	34	38	40	46	48
Side load filter sections—depth, in									
Flat 2" and 4"	12	12	12	12	12	12	12	12	12
2" angular	32	32	32	32	32	32	32	30	30
Cartridge (12" deep w/ 2" pre-filter)	22	22	22	22	22	22	22	22	22
Bag (36" w/ 2" pre-filter)	42	42	42	42	42	42	42	42	42
Front load filter sections—depth, in									
Cartridge (12" deep w/ 2" pre-filter)	16	16	16	16	16	16	16	16	16
Bag (36" w/ 2" pre-filter)	40	40	40	40	40	40	40	40	40
Face and bypass—depth, in									
Internal	12	12	12	12	12	12	12	12	12
External	18	18	18	20	22	24	24	26	30
Coil sections—depth, in									
Heating only (2-row water)	12	12	12	12	12	12	12	12	16
Cooling only (4-row water)	24	24	24	24	24	24	24	24	24
Cooling only (6-row water)	24	24	24	24	24	24	24	24	24
Clg (12-row) & reheat (1-row)	36	36	36	36	36	36	36	36	36
Access sections—depth, in									
16" deep	16	16	16	16	16	16	16	16	16
24" deep	24	24	24	24	24	24	24	24	24
30" deep	30	30	30	30	30	30	30	30	30
36" deep	36	36	36	36	36	36	36	36	36
42" deep	42	42	42	42	42	42	42	42	42
48" deep	48	48	48	48	48	48	48	48	48
54" deep	54	54	54	54	54	54	54	54	54
Diffuser—depth, in									
With housed fan	10	10	10	12	12	16	16	16	16
With inline fan	N/A	N/A	N/A	N/A	N/A	18	18	18	22
Attenuator—depth, in									
Short	40	40	40	40	40	40	40	40	40
Medium	52	52	52	52	52	52	52	52	52
Long	64	64	64	64	64	64	64	64	64
Supply or return plenum—depth, in									
Top, bottom or end opening	14	16	16	18	20	22	22	24	28

* Based on typical industry sizes. Skyline air handling units are available in 2 inch increments of height and width to fit the exact space requirements. Front load filter sections include 24" upstream plenum section with tread plate for heavy duty floor liner.

Commercial Outdoor Air Handling Products

Physical Data—Quick Select Table*—Skyline 025 through 090

Description	Unit size								
	025	030	035	045	055	065	080	085	090
Airflow range, cfm	7300-19,400	8500-22,500	10,000-26,500	9600-25,500	11,400-30,200	20,000-54,000	21,500-57,500	23,100-61,600	24,600-65,600
cfm @ 500 ft/min through large face area coil	12,150	14,150	16,700	19,300	24,500	33,300	35,900	38,450	41,000
Height x width, in	66 x 86	66 x 98	72 x 102	84 x 106	96 x 106	92 x 136	98 x 136	104 x 136	110 x 136
Cooling coil face area, sq.ft.									
Staggered large	27.4	31.9	37.1	50.4	N/A	76.9	82.0	87.1	92.2
Large	24.3	28.3	33.4	42.6	50.4	66.6	71.8	76.9	82.0
Staggered medium	21.3	24.8	29.7	34.9	46.5	61.5	61.5	66.6	71.8
Medium	18.2	21.2	24.1	31.0	38.8	51.2	51.2	56.4	61.5
Small	16.7	19.5	22.3	27.1	34.9	46.1	46.1	51.2	56.4
Fan section—depth, in									
Largest housed fan avail. w/ top hor. dis.	58	58	58	58	60	92	92	92	92
Largest inline fan and motor available	64	64	70	82	82	96	96	96	96
Largest belt drive plenum fan available	56	58	62	66	66	82	82	82	82
Largest direct drive plenum fan available	66	68	84	86	92	86	N/A	N/A	N/A
Largest twin fan and motor available	66	74	82	78	78	N/A	N/A	N/A	N/A
Largest 1 x 3 fan array and motor available	40	40	46	52	52	52	52	52	52
Largest 2 x 2 fan array and motor available	40	40	46	52	52	58	62	64	64
Largest 2 x 3 fan array and motor available	40	40	46	52	52	52	52	52	52
Mixing box—depth, in									
Mixing box only	32	32	36	42	48	46	50	54	56
Mixing box with flat filter	—	—	—	—	—	50	54	58	60
Mixing box with angular filter	—	—	—	—	—	68	72	76	78
Economizer—depth, in									
Depth	84	86	100	106	112	92	100	108	112
Blender—depth, in									
Largest Kees	46	48	58	64	68	76	80	84	84
Largest Blender Products IV	52	60	64	70	70	88	88	92	92
Side load filter sections—depth, in									
Flat 2" and 4"	12	12	12	12	12	12	12	12	12
2" angular	32	32	32	32	32	32	32	32	32
Cartridge (12" deep w/ 2" pre-filter)	22	22	22	22	22	22	22	22	22
Bag (36" w/ 2" pre-filter)	42	42	42	44	44	42	42	42	42
Front load filter sections—depth, in									
Cartridge (12" deep w/ 2" pre-filter)	16	16	16	20	20	16	16	16	16
Bag (36" w/ 2" pre-filter)	40	40	40	44	44	40	40	40	40
Face and bypass—depth, in									
Internal	12	12	12	12	12	12	12	12	12
External	32	32	34	44	50	50	54	56	58
Coil sections—depth, in									
Heating only (2-row water)	12	12	12	16	16	12	12	12	12
Cooling only (4-row water)	36	36	36	48	48	18	18	18	18
Cooling only (6-row water)	42	42	42	48	48	24	24	24	24
Clg (12-row) & reheat (1-row)	42	42	42	42	42	36	36	36	36
Access sections—depth, in									
16" deep	16	16	16	16	16	16	16	16	16
24" deep	24	24	24	24	24	24	24	24	24
30" deep	30	30	30	30	30	30	30	30	30
36" deep	36	36	36	36	36	36	36	36	36
42" deep	42	42	42	42	42	42	42	42	42
48" deep	48	48	48	48	48	48	48	48	48
54" deep	54	54	54	54	54	54	54	54	54
Diffuser—depth, in									
With housed fan	24	24	24	30	30	30	30	30	30
With inline fan	26	26	28	30	32	38	38	38	38
Attenuator—depth, in									
Short	40	40	40	40	40	40	40	40	40
Medium	52	52	52	52	52	52	52	52	52
Long	64	64	64	64	64	64	64	64	64
Supply or return plenum—depth, in									
Top, bottom or end opening	30	30	32	32	40	42	48	52	54

* Based on typical industry sizes. Skyline air handling units are available in 2 inch increments of height and width to fit the exact space requirements. Front load filter sections include 24" upstream plenum section with tread plate for heavy duty floor liner.

RoofPak™ Model RDS and RAH Air Handlers—4000 to 50,000 cfm

- Modular, walk-in, hinged construction
- 100% make up air, dehumidification, VAV, or constant volume operation
- Multiple factory-installed options for customized flexibility
- Blow-through or Draw-through cooling coil and filter configurations
- Controls flexibility—MicroTech® III controls with our Open Choices™ feature for easy integration with the BAS of your choice
- Heavy duty construction and independent IBC seismic certification (optional)

For more detail,
refer to Catalog 218.

For the most current
information, refer to
DaikinApplied.com.



Model RDS—4000 to 20,000 cfm

Model RAH—12,000 to 50,000 cfm

Optional electrical

- Disconnects, starters, lights, and VFDs
- Single source power and branch short circuit protection complete with ETL label
- Factory-installed, preprogrammed, and tested static pressure and temperature controls complete with valve packages or face and bypass control

Optional heating

- Gas with SuperMod™ high turndown gas burners
- Electric
- Hot water
- Steam



RoofPak™ Model RDS and RAH Air Handlers—4,000 to 50,000 cfm

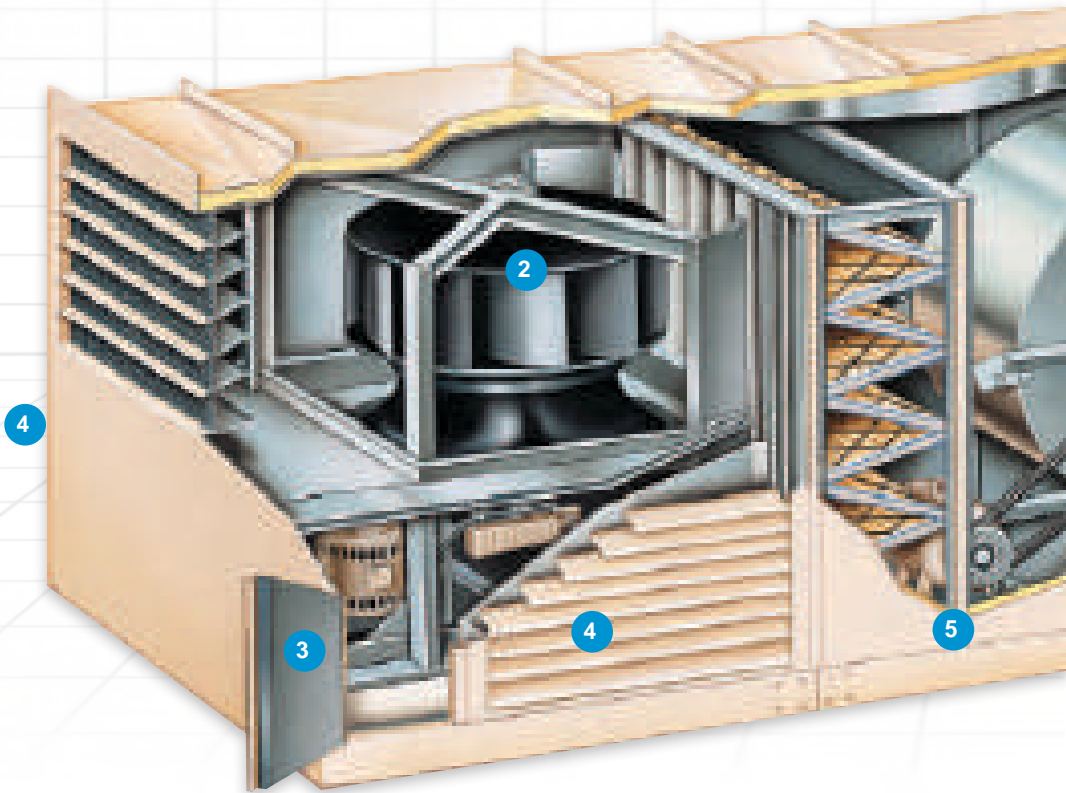

1 Airfoil fans

- More energy efficient and quieter than forward curved fans
- Double width, double inlet (DWDI) or single width, single inlet (SWSI) plenum fans



2 Return or exhaust fan

- Customize the unit to fit the application and return duct pressure drop
- Return fans provide better building pressure and ventilation control as return duct pressure drop increases
- Exhaust fans can save energy as return duct pressure drop requirements decrease



3 Hinged access doors

- On both sides of every section for easy access to all components
- Single lever latch and door holders provide easy entry and support routine maintenance
- Double-wall construction protects insulation during maintenance

4 Economizer

- Outside air enters from both sides, improving mixing for better temperature control
- DesignFlow Precision Ventilation Air Control System accurately measures and maintains ventilation air intake
- Patented UltraSeal™ low leak dampers minimize air leakage, reducing energy costs

5 Factory-mounted variable frequency drives

- Control fan motor speed for lower fan operating costs and sound levels in VAV systems



6 Blank sections

- Available throughout unit to factory-mount air blenders, carbon or charcoal filters, sound attenuators (shown), humidifiers, or other specialty equipment
- Allow customizing for maximum system performance and efficiency
- Reduced design and installation costs



RoofPak Model RDS and RAH Air Handlers Features and Options

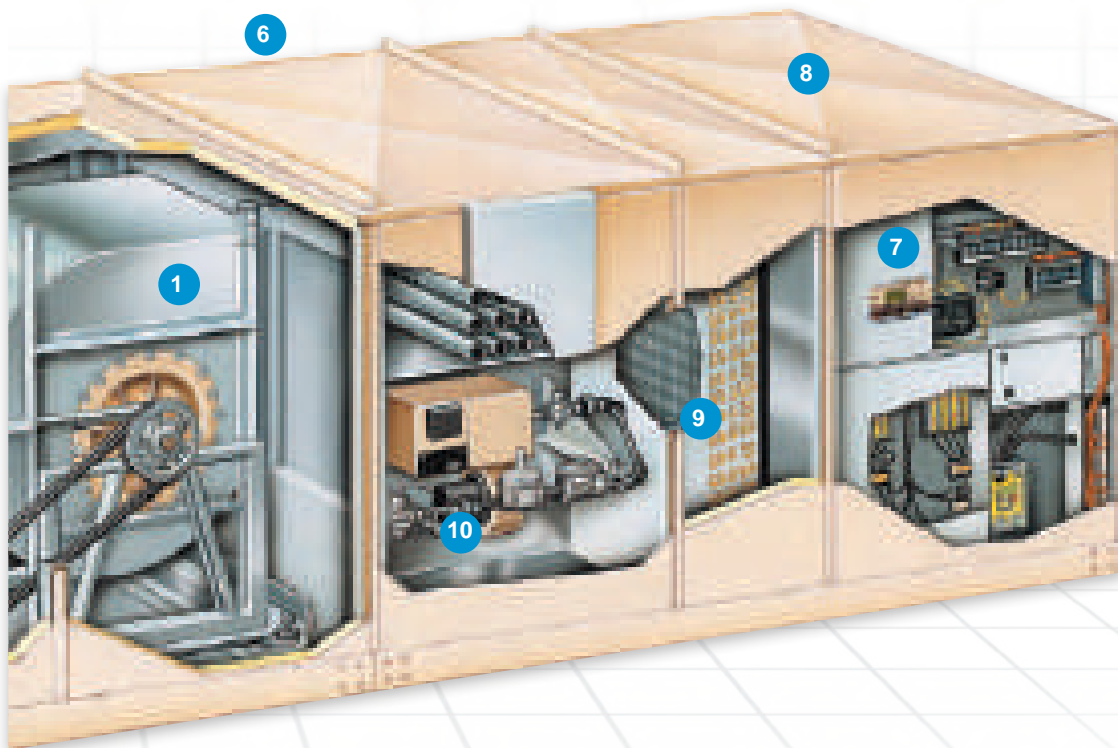

7 MicroTech® III control system

- Factory-installed and tested to minimize costly field commissioning.
- Open Choices™ feature for easy integration with the BAS of your choice using open, standard communication options such as BACnet® or LONWORKS®
- Easily accessed for system diagnostics and adjustments via a keypad/display on unit
- Minimum outdoor air and humidity control logic for fresh air intake and optimum humidity levels
- Optionally add a remote keypad and display that is identical to the unit-mounted user interface



8 Durable construction

- Pre-painted exterior cabinet panels pass ASTM B 117 Salt Spray Test for durability
- Capped seams prevent water leaks into the cabinet
- Cross-broken top panels eliminate standing water
- Double-wall construction protects R-6.5 insulation and provides wipe clean surface
- Stainless steel, sloped drain pans eliminate standing water

9 Blow-through or draw-through cooling coils

- Customize the unit to fit the application and building load
- Blow through provides greater sensible heat ratios and colder unit leaving air temperature per ton
- Draw-through arrangement provides more dehumidification per ton
- Factory-installed valve packages are offered for many chilled water, hot water, and steam coils

10 SuperMod high turndown gas burner

- Full 20:1 turndown and multiple sizes enable precise temperature control at reduced design, installation, and life cycle costs
- Maintain comfortable tenant environment in VAV, 100% make-up air, and dehumidification applications

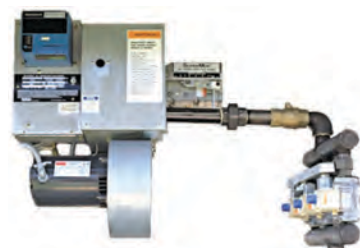

RoofPak Model RDS and RAH Air Handlers Features and Options

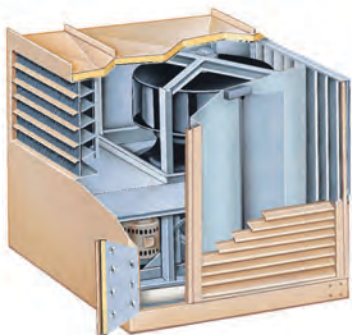

DesignFlow™ precision ventilation air control system

- Accurately measures and maintains minimum ventilation air intake to satisfy IAQ standards



SuperMod™ high turndown gas burners

- Full 20:1 turndown and multiple sizes enable precise temperature control at reduced design, installation, and life cycle costs
- Maintain comfortable tenant environment in VAV, 100% make-up air, and dehumidification applications

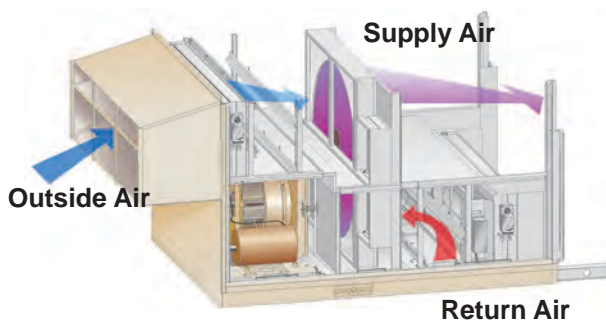

Energy recovery wheel

- Recovers approximately 75% of the energy from exhaust air stream
- Allows mechanical refrigeration, heating, and humidifying capacities to be reduced, offsetting the initial cost of the energy recovery wheel
- Cuts winter humidification energy costs by up to 60%
- Provides 100% more summer energy recovery than sensible-only energy recovery devices
- Helps provide a comfortable and affordable indoor environment
- Satisfies ASHRAE Standard 90.1 requirements for energy recovery on applications involving more than 70% minimum outdoor air and 5000 total cfm

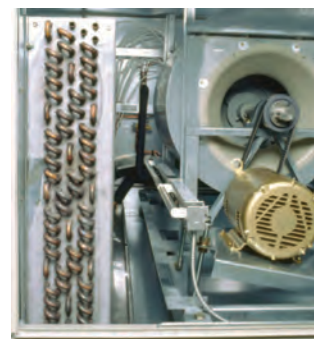

Optional UVGI lights

- Improves IAQ by destroying microorganisms on coil and drain pan surfaces
- Includes door interlocks to prevent eye contact with the UV-C ultraviolet light
- Satisfies GSA requirement for UVGI lights downstream of all cooling coils

Commercial Outdoor Air Handling Products

Physical Data—RDS 708B, 800C and 802C

Data		Unit size		
		708B	800C	802C
Cabinet	Length (in)	114–279	62–538	84–566
	Height (in)	51.0	55.5	55.5
	Width (in)	67.5	94.0	94.0
Supply fans	Type	Forward curved		
	Qty–dia. (in)	1–15 × 6	2–15 × 6	1–24
	Qty–dia. (in)	1–15 × 9	2–15 × 15	—
	Qty–dia. (in)	1–15 × 15 ¹	—	—
	Airflow range (cfm)	2000–8000	4000–16,000	8000–20,000
	Motor hp range	1–7.5	1–20	1–25
	Type	Backward curved with or without vanes		
	Qty–dia. (in)	—	—	1–24
	Airflow range (cfm)	—	—	8000–20,000
	Motor hp range	—	—	1–25
	Type	Airfoil with or without vanes		
	Qty–dia. (in)	1–16	1–20	—
	Airflow range (cfm)	2000–8000	4000–16,000	—
	Motor hp range	1–10	1–25	—
	Return fans	Type	Forward curved	
Qty–dia. (in)		1–15 × 15 ¹	2–15 × 15	—
Airflow range (cfm)		2000–7200	3000–14,400	—
Motor hp range		1–5	1–10	—
Type		Airfoil with or without vanes		
Qty–dia. (in)		1–16	1–30	1–30
Qty–dia. (in)		—	—	1–40
Airflow range (cfm)		2000–7200	3000–14,400	6000–18,000
Motor hp range		1–5	1–10	1–10
Throwaway 30% pleated, cleanable filters		Area (sq ft)	13.9 ²	50.0
	Qty–size (in)	4–20 × 25 × 2 —	10–16 × 20 × 2 10–16 × 25 × 2	10–16 × 20 × 2 10–16 × 25 × 2
	Area (sq ft)	20.8 ³	—	—
	Qty–size (in)	6–20 × 25 × 2 —	—	—
65% cartridge filters with 2" prefilters	Area (sq ft)	6.02	—	24.0
	Qty–size (in)	1–24 × 24 × 12 1–12 × 24 × 12	4–24 × 24 × 12 4–12 × 24 × 12	4–24 × 24 × 12 4–12 × 24 × 12
	Area (sq ft)	12.0 ³	—	—
	Qty–size (in)	2–12 × 24 × 12 2–24 × 24 × 12	—	—
95% cartridge filters with 2" prefilters	Area (sq ft)	8.0 ²	24.0	24.0
	Qty–size (in)	2–24 × 24 × 12 —	4–24 × 24 × 12 4–12 × 24 × 12	4–24 × 24 × 12 4–12 × 24 × 12
	Area (sq ft)	14.0 ³	—	—
	Qty–size (in)	2–24 × 24 × 12 3–12 × 24 × 12	—	—
Gas, oil furnace ⁴	Input (MBh)	—	250, 312, 400, 500, 625, 800, 812, 988, 1000, 1250	
	Nominal output (MBh)	—	200, 250, 320, 400, 500, 640, 650, 790, 800, 1000	
Electric ⁴	Nominal output (kW)	—	20, 40, 60, 80, 100, 120, 140, 160, 180, 200, 220, 240	

1. On RDS 708B, the 15" × 15" supply and return fans are available with or without variable inlet vanes.

2. Filter area for RDS 708B units with a 15" × 6" supply fan.

3. Filter area for RDS 708B units with a 15" × 9", 15" × 15" or 16" supply fan.

4. Gas, oil and electric heat selection is limited by the minimum airflow requirements.

Commercial Outdoor Air Handling Products

Physical Data—RDS 708B, 800C and 802C

Data ¹		Unit size							
		708BS		708BL		800CY		802C	
		Without F&BP	With F&BP	Without F&BP	With F&BP	Without F&BP	With F&BP	Without F&BP	With F&BP
Physical	Fin height (in) ²	12–39	12–30	12–39	12–30	12–36	12–30	12–36	12–30
	Fin length (in)	36		48		79		79	
	Max. coil depth (in) ³	25.0	20.0	25.0	20.0	19.5	19.5	19.5	19.5
	Max. face area (sq ft)	9.8	7.5	13.0	10.0	19.8	16.5	19.8	16.5
	Bypass area (sq ft)	—	1.9	—	2.5	—	3.3	—	3.3
	Max bypass cfm	—	4,750	—	6,250	—	8,225	—	8,225
Chilled water coils	Diameter (in)	5/8							
	Type—rows	5MH–2				5MH–2			
	Type—rows	5WH–3, 4, 5, 6, 8, 10				5WH–, 4, 5, 6, 8, 10			
	Type—rows	5WL–3, 4, 5, 6, 8, 10				5WL–3, 4, 5, 6, 8, 10			
	Type—rows	5MS–2				5MS–2			
	Type—rows	5WS–4, 6, 8, 10				5WS–4, 6, 8, 10			
	Type—rows	5WM–5, 6, 8, 10				5WM–5, 6, 8, 10			
	Type—rows	5WD–8				5WD–8			
Evaporator coils	Diameter (in)	5/8							
	Type—rows	5EN–2, 3, 4, 5, 6, 8				5EN–2, 3, 4, 5, 6, 8			
	Type—rows	SER–6				SER–6			
	Type—rows	5EF–2, 3, 4, 5, 6, 8				5EF–2, 3, 4, 5, 6, 8			
	Type—rows	5EJ–3, 4, 6, 8				5EJ–3, 4, 6, 8			
	Type—rows	5EK–4, 8				5EK–4, 8			
Hot water coils	Diameter (in)	5/8							
	Type—rows	5WB–1, 2				5WB–1			
	Type—rows	5WQ–1				5WQ–1			
	Type—rows	5WH–1, 2				5WH–1			
	Type—rows	5WS–2				5MH–24			
	Type—rows	–				5MS–24			
Steam coils	Diameter (in)	5/8							
	Type—rows	5JA–1, 2				5JA–1, 2			
	Type—rows	5GA–1, 2				5GA–1, 2			
	Diameter (in)	1							
	Type—rows	8JA–1				8JA–1			
	Type—rows	8GA–1				8GA–1			

1. On RDS 708B, the 15" x 15" supply and return fans are available with or without variable inlet vanes

2. Filter area for RDS 708B units with a 15" x 6" supply fan.

3. Filter area for RDS 708B units with a 15" x 9", 15" x 15" or 16" supply fan.

4. Gas, oil and electric heat selection is limited by the minimum airflow requirements.

RDS 800/802C Unit Heating Coils¹

Tube diameter	5/8
Fin height (in) ²	39
Fin length (in)	75
Type/rows, hot water	5WH/1 and 5WS/2
Type/rows, steam	5JA/1

1. Valve packages available.

2. If cooling coil is in the same section, the cooling coil is limited to 8 rows.

Commercial Outdoor Air Handling Products

Physical Data—RAH 047C and 077C

Data		Unit size					
		047CS	047CL	047CY	077CS	077CL	077CY
Cabinet	Length (in)	96–552	96–576	96–504	96–624	96–696	96–600
	Height (in)	73.0	73.0	73.0	97.0	97.0	97.0
	Width (in)	99.0	99.0	99.0	99.0	99.0	99.0
Throwaway filters (standard)	Type	Throwaway					
	Area (sq ft)	73.9	73.9	73.9	116.1	116.1	116.1
	No.—size (in)	7–16 × 20 × 2 21–16 × 25 × 2	7–16 × 20 × 2 21–16 × 25 × 2	7–16 × 20 × 2 21–16 × 25 × 2	11–16 × 20 × 2 33–16 × 25 × 2	11–16 × 20 × 2 33–16 × 25 × 2	11–16 × 20 × 2 33–16 × 25 × 2
Throwaway filters (optional)	Type	30% pleated					
	Area (sq ft)	73.9	73.9	73.9	116.1	116.1	116.1
	No.—size (in)	7–16 × 20 × 2 21–16 × 25 × 2	7–16 × 20 × 2 21–16 × 25 × 2	7–16 × 20 × 2 21–16 × 25 × 2	11–16 × 20 × 2 33–16 × 25 × 2	11–16 × 20 × 2 33–16 × 25 × 2	11–16 × 20 × 2 33–16 × 25 × 2
	Type	Prefilter, standard flow					
	Area (sq ft)	40.0	40.0	40.0	56.0	56.0	56.0
	No.—size (in)	4–12 × 24 × 2 8–24 × 24 × 2	4–12 × 24 × 2 8–24 × 24 × 2	4–12 × 24 × 2 8–24 × 24 × 2	4–12 × 24 × 2 12–24 × 24 × 2	4–12 × 24 × 2 12–24 × 24 × 2	4–12 × 24 × 2 12–24 × 24 × 2
	Type	Prefilter, medium flow					
	Area (sq ft)	48.0	48.0	48.0	64.0	64.0	64.0
	No.—size (in)	8–12 × 24 × 2 8–24 × 24 × 2	8–12 × 24 × 2 8–24 × 24 × 2	8–12 × 24 × 2 8–24 × 24 × 2	— 16–24 × 24 × 2	— 16–24 × 24 × 2	— 16–24 × 24 × 2
	Type	Prefilter, high flow					
	Area (sq ft)	—	—	—	80.0	80.0	80.0
	No.—size (in)	—	—	—	8–12 × 24 × 2 16–24 × 24 × 2	8–12 × 24 × 2 16–24 × 24 × 2	8–12 × 24 × 2 16–24 × 24 × 2
Cartridge filters	Type	65% or 95%, standard flow					
	Area (sq ft)	40.0	40.0	40.0	56.0	56.0	56.0
	No.—size (in)	4–12 × 24 × 12 8–24 × 24 × 12	4–12 × 24 × 12 8–24 × 24 × 12	4–12 × 24 × 12 8–24 × 24 × 12	4–12 × 24 × 12 8–24 × 24 × 12	4–12 × 24 × 12 8–24 × 24 × 12	4–12 × 24 × 12 8–24 × 24 × 12
	Type	65% or 95%, medium flow					
	Area (sq ft)	48.0	48.0	48.0	64.0	64.0	64.0
	No.—size (in)	8–12 × 24 × 12 8–24 × 24 × 12	8–12 × 24 × 12 8–24 × 24 × 12	8–12 × 24 × 12 8–24 × 24 × 12	— 16–24 × 24 × 12	— 16–24 × 24 × 12	— 16–24 × 24 × 12
	Type	65% or 95%, high flow					
	Area (sq ft)	—	—	—	80.0	80.0	80.0
	No.—size (in)	—	—	—	8–12 × 24 × 12 16–24 × 24 × 12	8–12 × 24 × 12 16–24 × 24 × 12	8–12 × 24 × 12 16–24 × 24 × 12
DWDI supply fans	Type	Forward-curved, LP/MP Airfoil, with or without vanes					
	Diameter (in)	27, 30, 33	27, 30, 33	27, 30, 33	33, 36, 40	33, 36, 40	33, 36, 40
	Max. airflow (cfm)	30,000	30,000	30,000	50,000	50,000	50,000
	Motor hp range	3–50	3–50	3–50	5–75	5–75	5–75
SWSI supply fans	Type	Airfoil, with or without vanes					
	Diameter (in)	40, 44	40, 44	40, 44	44, 49	44, 49	44, 49
	Max. airflow (cfm)	30,000	30,000	30,000	50,000	50,000	50,000
	Motor hp range	3–50	3–50	3–50	5–75	5–75	5–75
Return fans	Type	Airfoil, with or without vanes					
	Diameter (in)	40	40	40	44	44	44
	Max. airflow (cfm)	27,000	27,000	27,000	45,000	45,000	45,000
	Motor hp range	2–30	2–30	2–30	5–60	5–60	5–60
Exhaust fans	Type	Propeller					
	Diameter (in)	36 inch					
	Quantity	1–2 per unit			2–3 per unit		
	Motor hp	5 hp each					
	Airflow range	11,000–30,000 cfm			22,000–50,000 cfm		
Electric	Nom. output (kW)	*40, 60, 80, 100, 120, 160, 200, 240			*80, 100, 120, 160, 200, 240, 280, 320		
Gas furnace	Input (MBh)	*250, 312, 400, 500, 625, 800, 812, 988, 1000, 1250			*625, 800, 812, 988, 1000, 1250, 1375, 1750, 2500		
	Nom. output (MBh)	200, 250, 320, 400, 500, 640, 650, 790, 800, 1000			*500, 640, 650, 650, 790, 800, 1000, 1100, 1400, 1500, 2000		

* Furnace and electric heat size availability is limited by the minimum airflow.

Commercial Outdoor Air Handling Products

Physical Data—RAH 047C and 077C (continued)

Data ¹		Unit size							
		047CS		047CL		077CS		077CL	
		wo/ F&BP	w/ F&BP ²	wo/ F&BP	w/ F&BP ²	wo/ F&BP	w/ F&BP ²	wo/ F&BP	w/ F&BP ²
Evaporator coils	Rows	3, 4, 5, 6							
	Fins (per in)	8, 10, 12							
	Fin material	Aluminum, copper							
	FH x FL (in)	66 x 87.5	—	(2) 39 x 87.5	—	90 x 87.5	—	(2) 63 x 87.5	—
	Face area (sq ft)	40.1	—	47.4	—	54.7	—	76.6	—
	Max. cfm	26,000	—	30,800	—	35,500	—	49,800	—
	Chilled water coils	Type—rows valve package (in)	5WH—3, 4, 5, 6, 8						
		1½, 2, 2½	—	1½, 2, 2½	—	1¼, 1½, 2½, 3	—	2, 2½, 3	—
Type—rows valve package (in)		5WL—3, 4, 5, 6, 8							
		1½, 2, 2½	—	1½, 2, 2½, 3	—	1½, 2, 2½, 3	—	2, 2½, 3	—
Type—rows valve package (in)		5WS—4, 6, 8							
		2, 2½, 3	—	1½, 2, 2½, 3	—	1½, 2, 2½, 3	—	2, 2½, 3	—
Type—rows valve package (in)		5WM—4, 5, 6, 8							
		2, 2½, 3	—	1½, 2, 2½, 3	—	2, 2½, 3	—	2, 2½, 3	—
Type—rows valve package (in)		5WD—4, 8							
		2, 2½, 3	—	2, 2½, 3	—	2, 2½, 3	—	2, 2½, 3	—
Fins (per in)		8, 10, 12							
Fin material		Aluminum, copper							
FH x FL (in)		66 x 83	48 x 83	(2) 39 x 83	(2) 39 x 83	90 x 83	63 x 83	(2) 63 x 83	(2) 54 x 83
Face area (sq ft)		38.0	27.7	45.0	45.01	51.9	36.3	72.6	62.3
Max face cfm		24,700	18,000	29,200	29,200	33,700	23,600	47,200	40,500
Bypass area (sq ft)	—	9.2	—	10.4	—	14.4	—	18.4	
Max. bypass cfm	—	23,000	—	25,900	—	36,000	—	46,100	
Hot water coils	Type—rows ³ valve package (in)	5WH—1							
		1¼, 1½, 2, 2½, 3	—	1¼, 1½, 2, 2½, 3	—	1½, 2, 2½, 3	—	1½, 2, 2½, 3	—
	Type—rows ³ valve package (in)	5WS—2							
		1¼, 1½, 2, 2½, 3	—	1¼, 1½, 2, 2½, 3	—	1½, 2, 2½, 3	—	1½, 2, 2½, 3	—
	Fins (per in)	9							
	Fin material	Aluminum, copper							
	FH x FL (in)	57 x 75	39 x 75	57 x 75	—	81 x 75	54 x 75	81 x 75	—
	Face area (sq ft)	29.7	20.3	29.7	—	42.2	28.1	42.2	—
Bypass area (sq ft)	—	9.2	—	—	—	14.4	—	—	
Max. bypass cfm	—	23,000	—	—	—	36,000	—	—	
Steam coils	Type—rows ³ valve package (in)	1, 2							
		1¼, 1½, 2, 2½, 3	—	1¼, 1½, 2, 2½, 3	—	1½, 2, 2½, 3	—	1½, 2, 2½, 3	—
	Fins (per in)	6, 12							
	Fin material	Aluminum, copper							
	FH x FL (in)	57 x 75	39 x 75	57 x 75	—	81 x 75	54 x 75	81 x 75	—
	Face area (sq ft)	29.7	20.3	29.7	—	42.2	28.1	42.2	—
	Bypass area (sq ft)	—	9.2	—	—	—	14.4	—	—
	Max. bypass cfm	—	23,000	—	—	—	36,000	—	—

1. Unit coils are HI-F5 fin design.

2. Consult your local Daikin representative for specific face and bypass and control valve availability.

3. The valve package for hot water and steam heat is available only in the heating section.

Indoor Air Handler Product Summary Chart

Model:

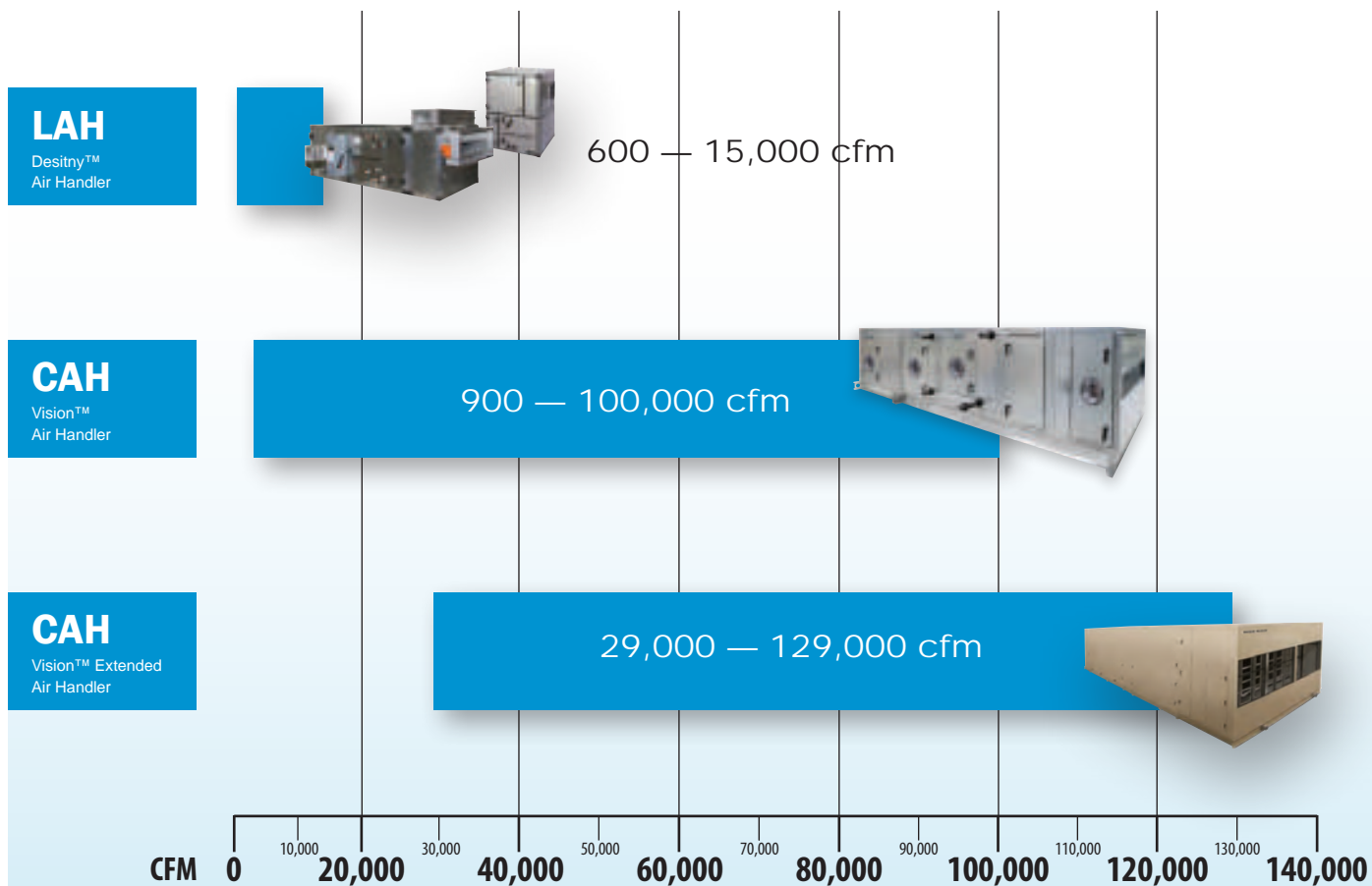

Destiny™ Air Handlers—2 to 30 ft² Face Area, 600 to 15,000 cfm

- Rugged, double-wall construction
- Internally isolated fan and motor for quiet operation
- IAQ compliant galvanized or stainless steel drain pan
- AHRI certified fan performance on all unit sizes
- Easy access on both sides of unit interior and optional bottom filter access

For more detail, refer to Catalog 580.

For the most current information, refer to DaikinApplied.com.

Model LAH—600 to 15,000 cfm

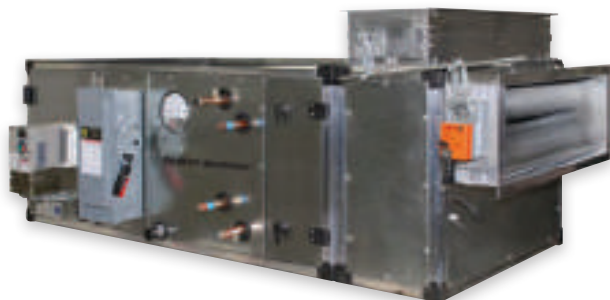

Horizontal Configuration



Vertical Configuration

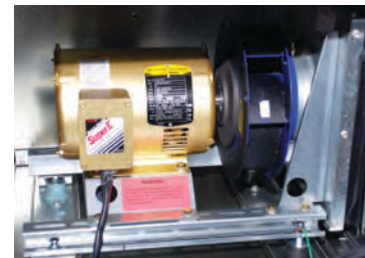

Internally isolated fan and motor

The Daikin Destiny™ indoor air handler is a full-featured, light air handler providing a single solution for blower coil and low pressure air handler applications. Destiny air handlers ranging from 600 to 15,000 cfm, eliminate the need to choose between the low cost of a blower coil and the performance of an air handler in new construction or retrofit building projects. They can be applied in any blower coil or small air handler application in offices, schools, hotels, government buildings, stores and hospitals. By offering one product design in a size range that traditionally has required two products, the Destiny air handler helps simplify your project design and specification, and it provides uniform installation procedures. Other features that simplify design, specification and installation include:

- Flexible coil and filter selections to match your application requirements
- Ceiling hung or floor mounted application flexibility in horizontal or vertical arrangements
- Higher operating static pressures than blower coils provide added flexibility in unit ducting and placement. Direct-drive plenum fans are more efficient and quieter than FC blower coil fans
- Field interchangeable coil allows units to be piped from either side to avoid clearance restrictions
- Blow-through electric heat with single point power connection
- Factory-mounted VFDs, starters, disconnects, and damper actuator to reduce field labor



Flexible coil and filter selections

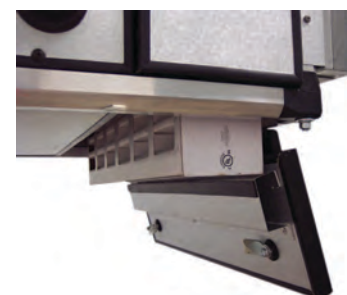

Bottom filter access panel

Destiny Air Handlers Feature and Options

Horizontal Configuration

Vertical Configuration

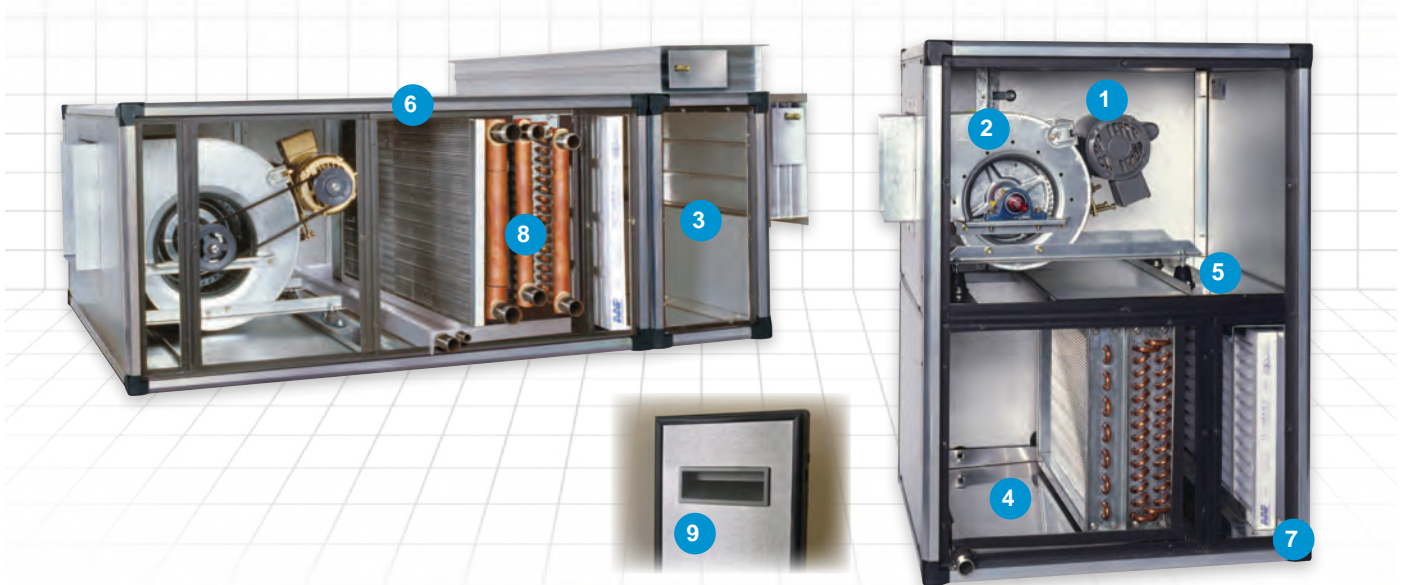

1 Standard and high-efficiency motor options

- Adjustable motor mount simplifies belt adjustments
- Drive side is field interchangeable to avoid clearance restrictions
- Motor power connection through external junction box

2 Direct-drive plenum fan for horizontal units

- Minimum turbulence for quiet, efficient operation
- Allows higher static pressure operation than blower coils for flexible ducting and unit placement
- Flex collar at discharge minimizes vibration transmission
- Flexible, end or top discharge arrangements

3 Mixing box selections

- Provide superior mixing of return and outside air streams in ducted return applications
- Optional factory mounted actuator and damper linkage for reduced field service labor

4 Galvanized or stainless steel sloped drain pan

- Eliminates standing water to inhibit microbial growth
- Connections on both sides to avoid clearance restrictions

5 Internally isolated fan and motor

- Minimizes vibration transmission for quiet operation
- Rubber in shear (sizes 002 to 010)
- Spring isolators (sizes 015 and larger)

6 Double-wall construction with foam-injected insulation

- Eliminates insulation fibers
- from the air stream
- Helps prevent dust buildup and provides wipe-clean surface
- Galvanized or optional Galvalume® steel panels for superior corrosion resistance

7 Aluminum frame and polymeric corners

- Provide rigidity and superior corrosion resistance
- Unique frame structure simplifies hanger bracket attachment

8 Flexible coil and filter options

- Allow you to match application requirements
- Coils are field interchangeable to avoid clearance restrictions
- Preheat and reheat arrangements available
- Flat or angular filters
- MERV-7 or MERV-8, 2" and 4" standard
- Optional high-efficiency (MERV-11 through MERV-15) filters

9 Access panels on both sides of each section

- Provide complete access to the unit interior
- Pocket pull handles provide an easy method to remove and handle access panels
- Optional hinged and quarter-turn latched access doors
- Optional bottom filter access for horizontal units
- Choice of casing materials

Destiny Air Handlers Features and Options



Electric heat

- Single point power connection for supply fan motor and heater
- 1.5 kW - 55 kW
- 1, 2, 3, or 4 steps (1 and 2 steps on size 002)
- Factory wired contactors and fuses per step
- Factory wired motor contactors or starter and fuses as applicable
- Non-fused disconnect switch
- 24 volt control transformer
- Complete with overload and thermal protection
- High quality alloy nichrome wire (80% Ni and 20% Cr)
- Horizontal and vertical air flow arrangements
- Control box with tool access hinged door



Starter/disconnects

- Factory mounted and wired
- Disconnect only option: fused or non-fused
- Full control box options: fused disconnect, motor starter, and 24 V transformer
- Software selectable
- Wiring diagrams generated as part of submittal package



Mixing section

- Provide superior mixing of return and outside air streams in ducted return applications
- Optional factory mounted actuator and damper linkage to reduce field labor



Variable frequency drive (VFD)

- Factory mounted and wired
- Daikin brand MD4 or MD5 or Telemechanique ATV-12
- Fused disconnect required



Direct drive plenum fan

- Higher static applications (up to 4" wg total)
- Multiple discharge directions
- Better static efficiency and less noise than a forward curved fan
- No belt maintenance and drive loss typically associated with a belt driven forward curved fan

Motor control options

- Standard motor wiring through external junction box
- Disconnect only: fused or non-fused
- Starter, disconnect, and transformer

Commercial Indoor Air Handling Products

Physical Data—Destiny

Fan Data

Unit size	002	003	004	005	007	010	015	020	025	030
Fan type	DWDI FC	DWDI FC	DWDI FC	DWDI FC	DWDI FC	DWDI FC	Twin DWDI FC	Twin DWDI FC	Twin DWDI FC	Twin DWDI FC
Diameter	7/7	9/9	9/9	10/10	12/12	12/12	10/10	12/12	15/15	15/15
HP range	.33–2	.33–3	.33–5	.75–5	1–5	1–7.5	2–15	3–15	5–20	5–20
CFM minimum–fan limit	206	206	529	529	765	765	1059	1529	2118	2118
CFM maximum–fan limit	2088	2088	5765	6176	8529	8529	12,353	17,059	26,706	26,706
Fan type	SWSI DD Plenum	SWSI DD Plenum	SWSI DD Plenum	SWSI DD Plenum	SWSI DD Plenum	SWSI DD Plenum	SWSI DD Plenum	SWSI DD Plenum	SWSI DD Plenum	SWSI DD Plenum
Diameter	9	10	11	12.5	14	16	20	22	25	25
HP range	1.5–2.0	1.5–5.0	1.0–5.0	1.0–5.0	1.0–7.5	1.0–7.5	1.5–15.0	2.0–15.0	5.0–20.0	5.0–20.0
CFM minimum–fan limit	100	150	200	200	250	325	525	650	800	800
CFM maximum–fan limit	1800	2650	4100	4100	5000	5200	9200	12,900	16,150	16,150

Filter Data

Unit size	002	003	004	005	007	010	015	020	025	030
Flat filter (qty) size	(1) 16 × 25	(1) 18 × 24	(2) 16 × 20	(2) 20 × 24	(2) 24 × 24	(3) 20 × 25	(3) 12 × 24 (3) 24 × 24	(6) 24 × 24	(4) 20 × 24 (4) 24 × 24	(6) 16 × 25 (4) 20 × 25
Flat filter depth options	2", 4"									
Angular filter (qty) size	(1) 20 × 24	(2) 16 × 20	(2) 20 × 20	(4) 16 × 20	(4) 16 × 25	(6) 16 × 20	(6) 20 × 24	(9) 20 × 24	(6) 20 × 24 (6) 24 × 24	(6) 20 × 24 (6) 24 × 24
Angular filter depth options	2"									

Commercial Indoor Air Handling Products

Physical Data—Destiny

Cabinet Dimensions—Horizontal Unit

Dimension/Configuration		Unit size									
		002	003	004	005	007	010	015	020	025	030
Cabinet Dimension		Unit height and width dimensions, in (mm)									
Height		20.47 (520)	22.44 (570)	22.44 (570)	28.35 (720)	28.35 (720)	32.48 (825)	39.37 (1000)	51.57 (1310)	51.57 (1310)	59.06 (1500)
Width		28.54 (725)	34.84 (885)	42.52 (1080)	42.52 (1080)	56.50 (1435)	63.00 (1600)	74.41 (1890)	75.00 (1905)	89.96 (2285)	89.96 (2285)
Configuration		Unit length dimensions, in (mm)									
Cooling only or cooling with reheat coils	Flat filter	47.84 (1215)	47.84 (1215)	53.35 (1355)	54.72 (1390)	58.86 (1495)	58.86 (1495)	53.74 (1365)	56.30 (1430)	62.00 (1575)	62.00 (1575)
	Angular filter	58.27 (1480)	55.12 (1400)	60.63 (1540)	65.95 (1675)	70.08 (1780)	70.08 (1780)	64.37 (1635)	71.26 (1810)	76.97 (1955)	80.12 (2035)
Cooling with preheat coils	Flat filter	51.97 (1320)	51.97 (1320)	59.25 (15.05)	59.45 (15.10)	65.55 (1665)	65.55 (1665)	62.80 (15.95)	65.35 (1660)	69.09 (17.55)	69.09 (17.55)
	Angular filter	62.40 (15.85)	59.25 (1505)	66.53 (1690)	70.67 (17.95)	76.77 (1950)	76.77 (1950)	73.42 (18.65)	80.32 (2040)	84.06 (2135)	87.20 (2215)
Heating only	Flat filter	39.96 (1015)	39.96 (1015)	45.47 (1155)	45.67 (1160)	49.80 (1265)	49.80 (1265)	52.56 (1335)	55.51 (1410)	61.42 (1560)	61.42 (1560)
	Angular filter	50.39 (1280)	47.24 (1200)	52.76 (1340)	56.89 (1445)	61.02 (1550)	61.02 (1550)	63.19 (1605)	70.47 (1790)	76.38 (1940)	79.53 (2020)
Ventilation only	Flat filter	39.96 (1015)	39.96 (1015)	45.47 (1155)	45.67 (1160)	49.80 (1265)	49.80 (1265)	52.56 (1335)	55.51 (1410)	61.42 (1560)	61.42 (1560)
	Angular filter	50.39 (1280)	47.24 (1200)	52.76 (1340)	56.89 (1445)	61.02 (1550)	61.02 (1550)	63.19 (1605)	70.47 (1790)	76.38 (1940)	79.53 (2020)
Discharge Opening Dimension		Discharge height and width dimensions in. (mm)									
Height		9.17 (233)	11.77 (299)	11.77 (299)	13.07 (332)	15.51 (394)	15.51 (394)	2 × 13.07* (332)	2 × 15.51* (394)	2 × 18.54* (471)	2 × 18.54* (471)
Width		8.74 (222)	10.20 (259)	10.20 (259)	11.34 (288)	13.46 (342)	13.46 (342)	2 × 11.34* (288)	2 × 13.46* (342)	2 × 15.83* (402)	2 × 15.83* (402)

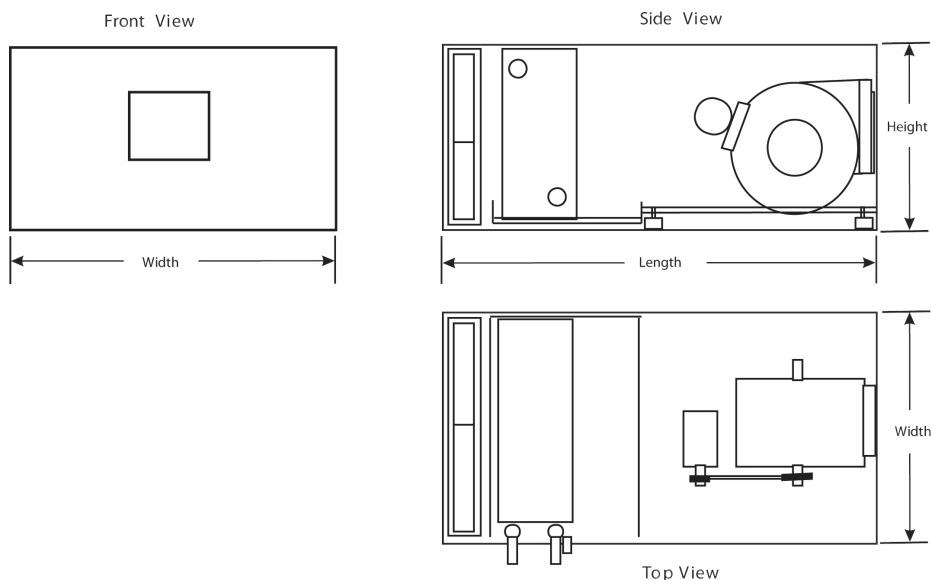

Commercial Indoor Air Handling Products

Physical Data—Destiny

Cabinet Dimensions—Vertical Unit

Dimensions	Unit size									
	002	003	004	005	007	010	015	020	025	030
Height—in (mm)	37.60 (955)	42.32 (1075)	42.32 (1075)	50.39 (1280)	52.95 (1345)	57.09 (1450)	63.19 (1605)	78.54 (1905)	82.87 (2285)	90.35 (2295)
Width—in (mm)	28.54 (725)	34.84 (885)	42.52 (1080)	42.52 (1080)	56.50 (1435)	62.99 (1600)	74.41 (1890)	75.00 (1905)	89.96 (2285)	89.96 (2285)
Length—in (mm)	29.92 (760)	33.07 (840)	33.07 (840)	36.42 (925)	39.96 (1015)	39.96 (1015)	42.72 (1085)	47.83 (1215)	51.18 (1300)	51.18 (1300)
Upper section height—in (mm)	17.13 (435)	19.88 (505)	19.88 (505)	22.05 (560)	24.61 (625)	24.61 (625)	23.82 (605)	26.97 (685)	31.30 (795)	31.30 (795)
Lower section height—in (mm)	20.47 (520)	22.44 (570)	22.44 (570)	28.35 (720)	28.35 (720)	32.48 (825)	39.37 (1000)	51.57 (1310)	51.57 (1310)	59.06 (1500)
Discharge Opening Dimensions	Unit height and width dimensions in. (mm)									
Height—in (mm)	9.17 (233)	11.77 (299)	11.77 (299)	13.07 (332)	15.51 (394)	15.51 (394)	13.07* (332)	15.51* (394)	18.54* (471)	18.54* (471)
Width—in (mm)	8.74 (222)	10.20 (259)	10.20 (259)	11.34 (288)	13.46 (342)	13.46 (342)	11.34 (288)	13.46 (342)	15.83 (402)	15.83 (402)

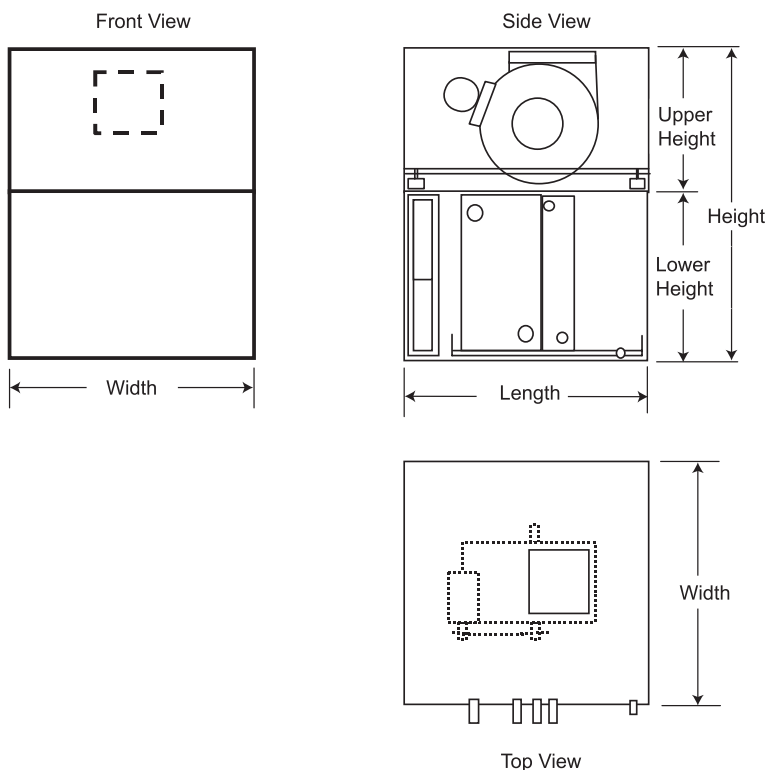

Physical Data—Destiny

Dimensions—Mixing Box, Horizontal and Vertical Units

Unit size	Cabinet, in (mm)			Damper, in (mm)		
	W	H	L	W1	L1	Area (ft ²)
002	28.54 (725)	20.47 (520)	10.24(260)	26.18 (665)	7.87 (200)	1.43
003	34.84 (885)	22.44 (570)	10.24 (260)	32.48 (825)	7.87 (200)	1.78
004	42.52 (1080)	22.44 (570)	10.24 (260)	40.16 (1020)	7.87 (200)	2.20
005	42.52 (1080)	28.35 (720)	14.17 (360)	40.16 (1020)	11.81 (300)	3.29
007	56.50 (1435)	28.35 (720)	14.17 (360)	54.13 (1375)	11.81 (300)	4.44
010	62.99 (1600)	32.48 (825)	14.17 (360)	60.63 (1540)	11.81 (300)	4.97
015	74.41 (1890)	39.37 (1000)	18.11 (460)	72.05 (1830)	15.75 (400)	7.88
020	75.00 (1905)	51.57 (1310)	25.98 (660)	72.64 (1845)	23.62 (600)	11.92
025	89.96 (2285)	51.57 (1310)	25.98 (660)	87.60 (2225)	23.62 (600)	14.37
030	89.96 (2285)	59.06 (1500)	29.92 (760)	87.60 (2225)	27.56 (700)	16.76

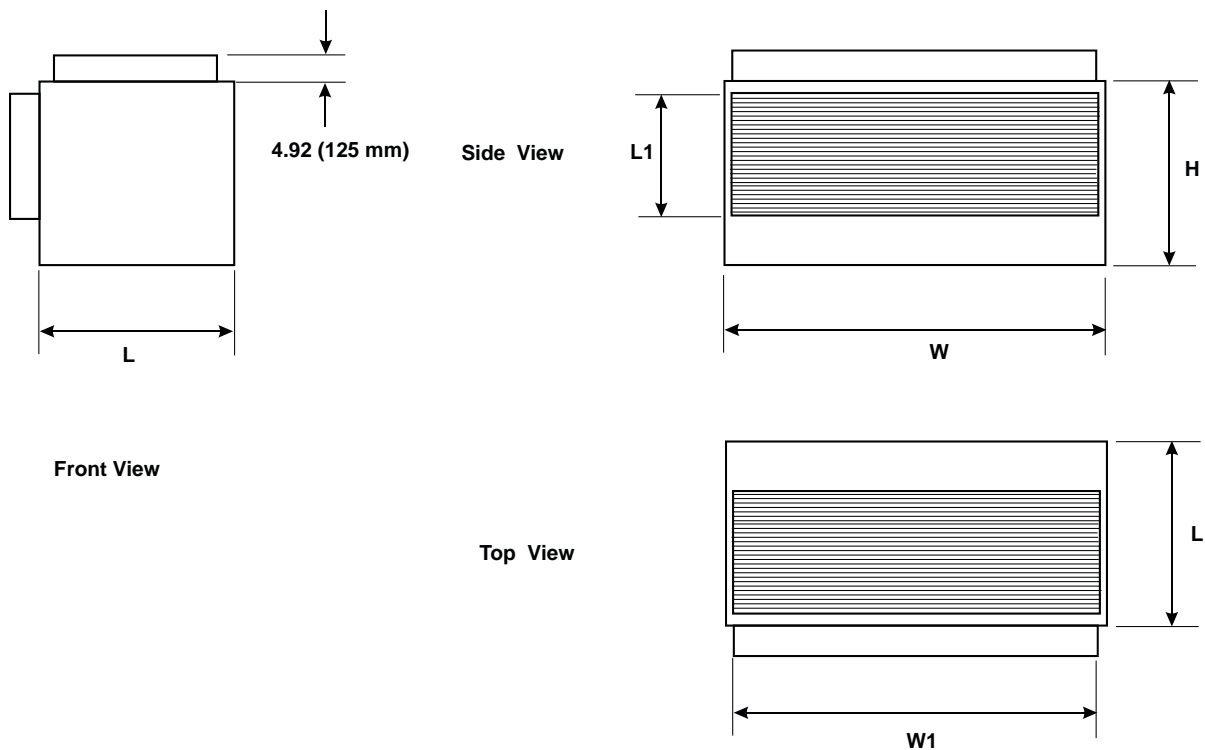

Commercial Indoor Air Handling Products

Physical Data—Destiny

Dimensions—Electrical Heat Box, Left and Right Hand Units (LAH 002A through LAH 005A)

Dimensions inches (mm)	Unit part number									
	LAH002A		LAH004A				LAH005A			
	1 step	2 steps	1 step	2 steps	3 steps	4 steps	1 step	2 steps	3 steps	4 steps
L	11-1/2 (292.1)	16 (406.4)	11-1/2 (292.1)	16 (406.4)	20 (508)	24 (609.6)	11-1/2 (292.1)	16 (406.4)	20 (508)	24 (609.6)
W	19-1/2 (495.3)		22-1/4 (565.1)				23-1/2 (596.9)			
H	20 (508)		22-1/4 (565.1)				23-1/2 (596.9)			

Dimensions—Electrical Heat Box, Left and Right Hand Units (LAH 007A through LAH 010A)

Dimensions inches (mm)	Unit part number							
	LAH007A				LAH010A			
	1 step	2 steps	3 steps	4 steps	1 step	2 steps	3 steps	4 steps
L	11-1/2 (292.1)	16 (406.4)	20 (508)	24 (609.6)	11-1/2 (292.1)	16 (406.4)	20 (508)	24 (609.6)
W	26 (660.4)							
H	25 (635)							

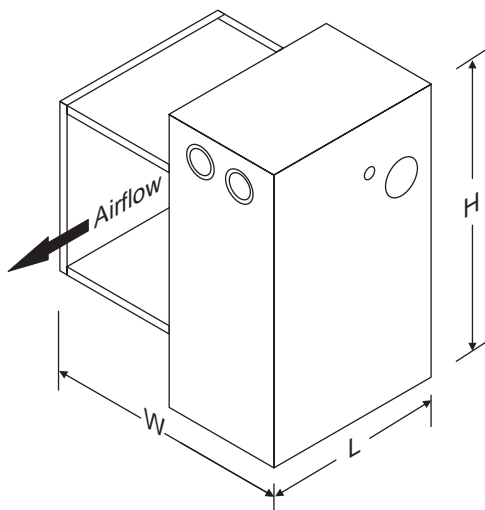

Left hand electrical heat box

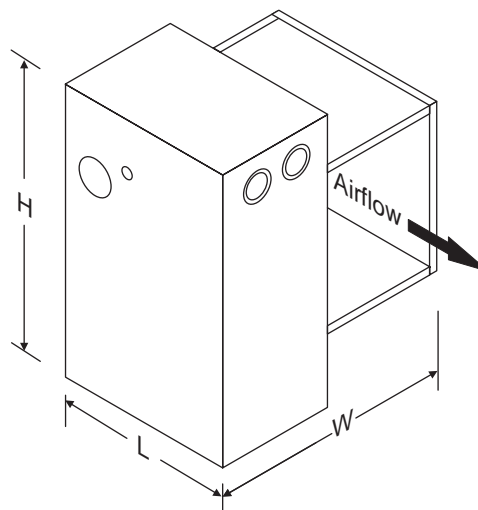

Right hand electrical heat box

Vision™ Air Handlers—3 to 160 ft² Face Area, 900 to 100,000 cfm

- Operating efficiency – dual direct drive or belt drive plenum fans, fan array, and energy recovery sections
- Flexibility – modular platform, 2-inch Variable Dimensioning™, multiple component options, unlimited configurations
- Extensive coil selections – cooling, heating, steam and evaporator coils with extended connections and gasketed seals
- Advanced filtration – HEPA, PCO, gas phase, and low pressure
- Indoor air quality – ultra-violet lights, stainless steel drain pan, and anti-microbial liner options
- Energy recovery – fixed plate heat exchanger and energy recovery wheel options
- Easy Maintenance – access and service vestibules, inward swinging doors, and inside door handle options

For more detail,
refer to Catalog 550
and Catalog 565.

For the most current
information, refer to
DaikinApplied.com.



Model CAH—900 to 100,000 cfm

Variable Height

26" – 122"
(2" increments)

Variable Width

36" – 142" (2" increments) and 144" – 228" (4" increments)



Extended size units available with
up to 160 ft² of coil face area

Vision Air Handlers Options

Use Daikin Vision as a product platform on which to build the ideal air handler for your specific application. Options include:

- Variable Dimensioning feature for flexible cabinet sizing
- Painted cabinet
- Multiple access section depths
- Variable base rail heights (4"–12")
- Various casing and drain pan materials
- Mixing boxes/economizers
- Sound attenuators
- Horizontal and vertical integral face and bypass dampers
- Blenders and air mixers
- Multiple coil section depths
- Electro-Fin epoxy coil coating
- Energy recovery sections (heat wheels, fixed plate heat exchangers, and runaround coil loops)
- Multiple fan selections: forward curve, airfoil, inline, and belt or direct drive plenum fans
- Dual direct-drive plenum fans
- Twin fans (two forward curved fans on one shaft)
- Dual fans and fan array setups for redundancy
- Filters (flat, angular, bag and cartridge) available in side-load and/or front-load configuration
- Humidifier manifold
- IBC seismic certification
- Multiple liner options
- Flush-mounted filter gauges
- Starters, VFDs, and disconnects
- Digital Ready™ factory control options
- Electric heaters
- Ultraviolet lights
- Inward opening doors
- Windows, doors, marine lights and receptacles
- Manual selections to accommodate special components
- Flexibility in shipping arrangements
- Dual path dehumidification
- Gas-phase filtration



Fan options



Disconnect, starter and VFD options



Digital Ready™ factory control options

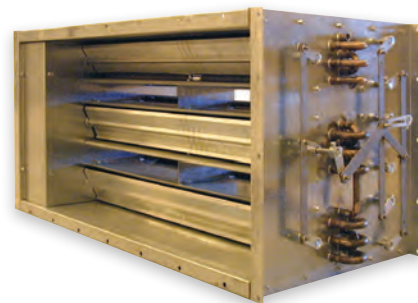

Integral face and bypass damper options

Vision™ Air Handler—3 to 160 ft² Face Area, 900 to 100,000 cfm

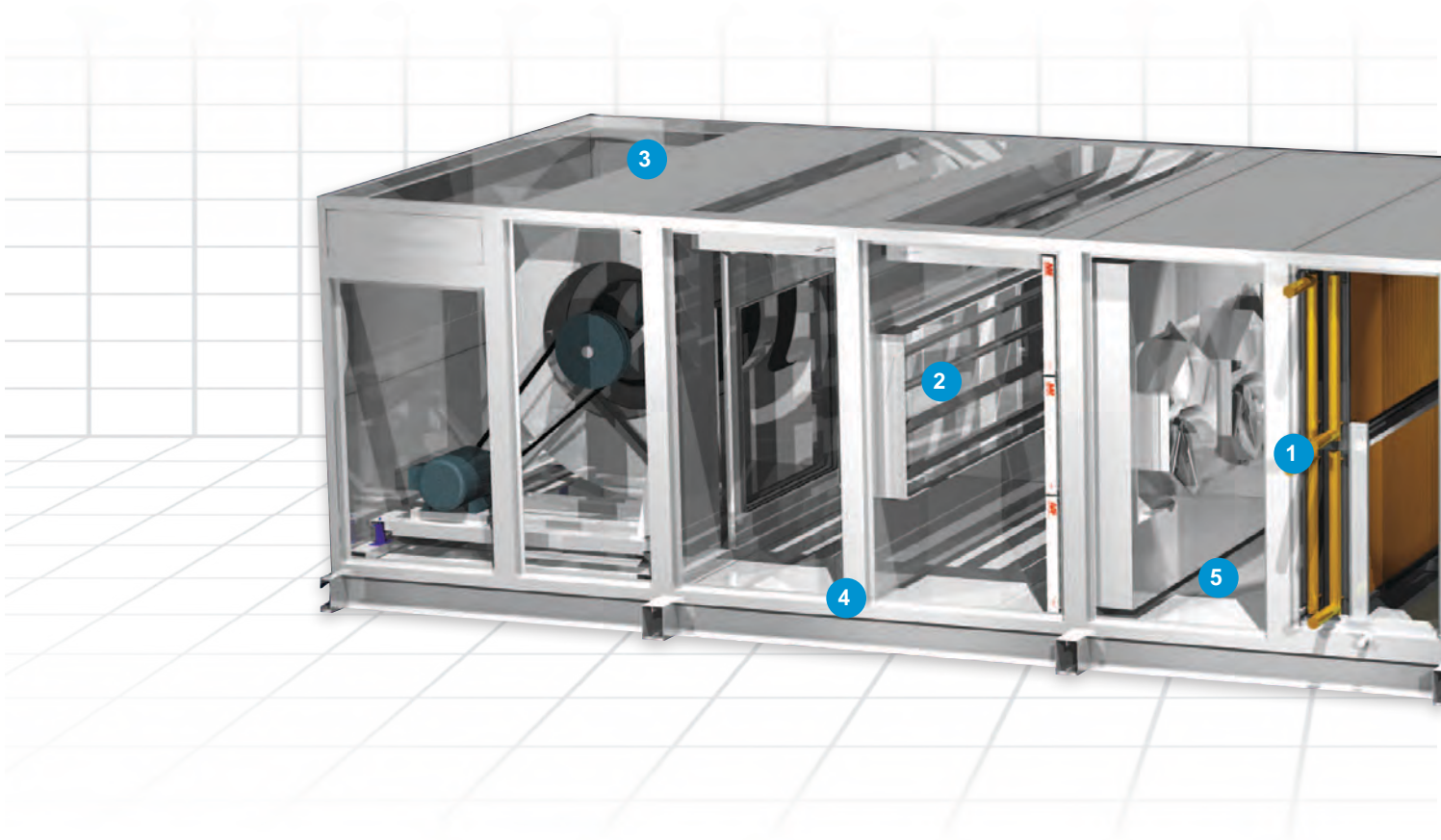

1 Extended coil connections

- Saves installation costs
- Reduces maintenance time
- Aids proper drainage



2 Patented UltraSeal™ low-leak dampers

- Maximize operating efficiency
- Reduce operating cost



3 Rugged cabinet enclosure

- Rigid thermally efficient (R-13) injected foam panels are strong and light weight
- G-90 galvanized or painted finish
- Low-leakage cabinet

4 Gasketed frame channel

- Eliminates metal-to-metal contact between paneling and framework
- Minimizes cabinet condensate and corrosion
- Facilitates top and side component removal
- Promotes long life

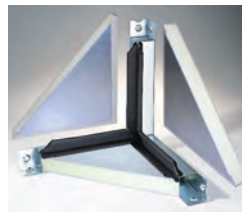

5 Smooth interior surface

- Reduces dirt accumulation
- Facilitates cleaning
- Improves IAQ



Vision Air Handlers Features and Options

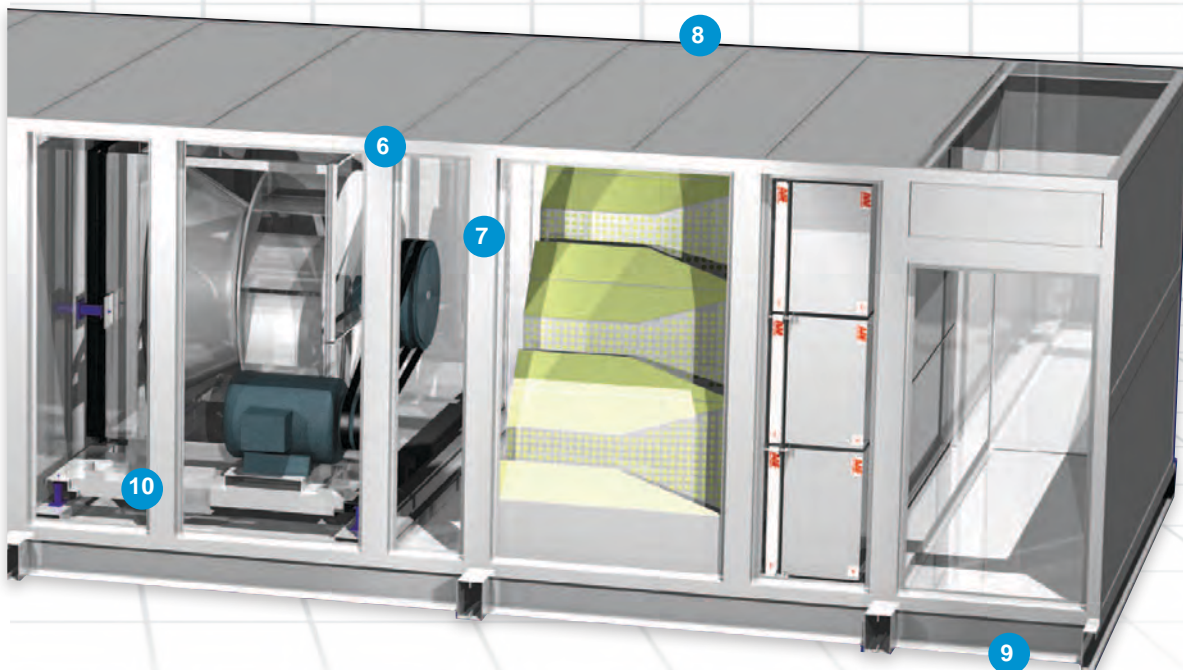

6 Frame channel disassembly

- Allows two-sided access
- Easier, faster service and maintenance



7 Patented splice collar

- Reduces installation cost
- Creates an air tight environment



8 Custom modular design with variable dimensioning feature

- Allows custom selection and configuration of components
- Allows design of system to meet space and performance requirements

9 Variable height base rails (4"–12")

- Eliminates costly housekeeping pad
- Allows for adequate condensate trapping



10 Visible double-sloped drain pan

- Makes inspection and cleaning easier
- Improves IAQ



Commercial Indoor Air Handling Products

Vision SelectTools™ Software Selection Program

Because of the Vision air handler's flexibility and various component types, there are an infinite number of unit arrangements. To help easily define product requirements, Daikin provides the user-friendly Vision SelectTools Software Selection Program to configure and size both standard and custom units. This Windows® based program leads you through the selection process by prompting for pertinent input data for all components. The program gives immediate feedback regarding fan and coil selection, offering a choice of several options based on performance inputs. Once final components are selected, the program provides all output needed for specification and submittal purposes, including required fan curves, coil performance psychrometric charts, weights, dimensional drawings, and a unit specification.

This capability is available in Daikin Tools™ for engineers' software. Ask your Daikin McQuay representative for details.

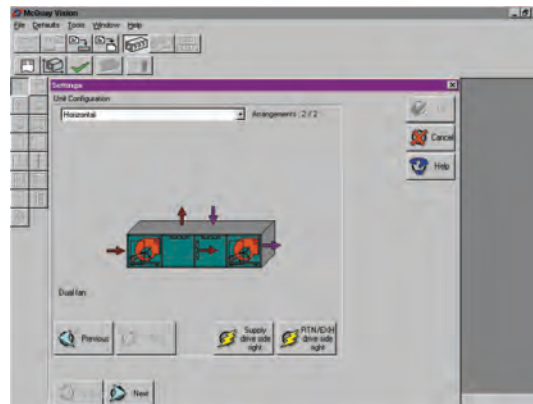

Quality Construction

Quality construction makes standard Vision units capable of leakage rates of less than 1%. Our patented, internal splice collar, factory-installed gasketing, and double-wall, injected foam insulated panels help to preserve the airtight environment. They also eliminate fibers and stop dirt and moisture from penetrating the casing. The results for your client can be quieter units than standard commercial air handlers, with lower operating costs and optimal indoor air quality.

Flexibility

Our unique Variable Dimensioning feature provides tremendous flexibility, allowing sizing of units in two-inch increments up to 142" and in four-inch increments up to 228". Numerous section and component options, and the ability to arrange components however required, allow Vision air handlers to be customized for each job without modifications in the field. Units can ship completely assembled, in modules, or by component sections for new or retrofit applications requiring smaller sections for passage through the building.

Panels and frame channels are easily removed for access to large components

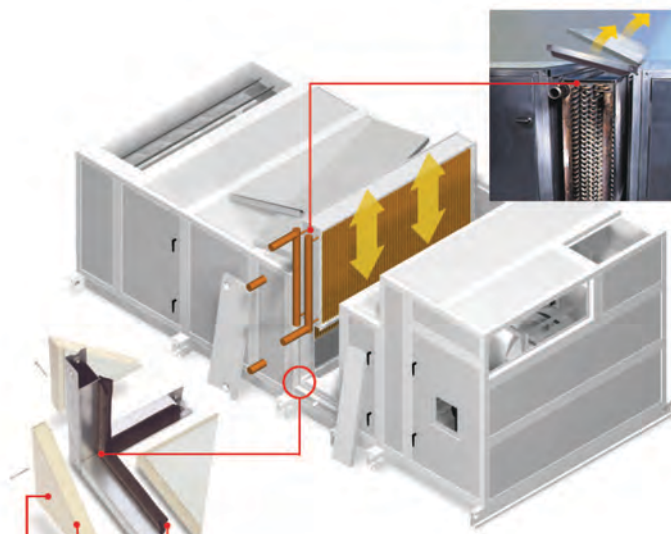

Gasketed frame channels
Double-wall, R-13 injected foam
Rigid, injected foam panels provide superior strength, improve operating efficiency, and reduce unit weight.

Vision Air Handlers Options

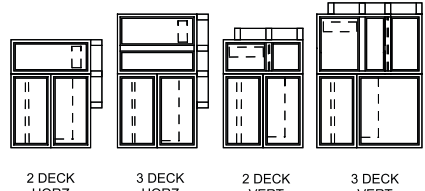
RETURN / EXHAUST	ECONOMIZER	BLENDER	FILTER	ENERGY RECOVERY	F & BP DAMPER	COIL	ACCESS	HORIZONTAL COIL	SUPPLY FAN	DIFFUSER	COIL BLOW THRU	ACCESS	FILTER	ATTENUATOR	PLENUM
PLENUM FAN	FC, AF FAN & TWIN FAN	2" & 4" ANGULAR	WHEEL	INTERNAL	HORIZ HEATING	LARGE	CLG. / HTG. COMBINATION	FC, AF FAN, & TWIN FAN		HORIZ		CARTRIDGE			DISCHARGE PLENUM
INLET PLENUM	ESI FAN	2" & 4" FLAT	FLAT PLATE CUBE	INTEGRAL	1 & 2 ROW STEAM AND 1-4 ROW WATER	MEDIUM	CLG. 10 ROW	PLENUM FAN		CLG. OR HTG.		BAG			
MIXBOX WITH 4" FILTER	MIXBOX WITH 2" FILTER	CARTRIDGE				SMALL	4 ROW	ESI FAN	MULTI-ZONE COIL SECTIONS 						
MIXING BOX	MIXBOX WITH ANG FILTER	BAG					SFA COIL, MFA COIL, F & BP	FAN AND VERTICAL COIL							



Multiple filter options

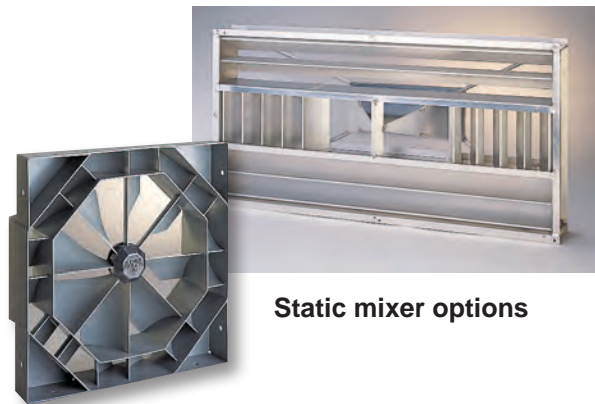

Static mixer options



Sound attenuator options



Energy recovery options

Commercial Indoor Air Handling Products

Physical Data—Vision

Quick Select Table*

Description	Unit size								
	003	004	006	008	010	012	014	017	021
Airflow range, cfm	900–2500	1200–3100	1700–4600	2200–6000	2900–7700	3600–9700	4200–11,200	5000–13,500	6000–16,000
cfm @ 500 ft/min through large face area coil	1550	1950	2850	3750	4800	6050	7000	8400	10,050
Height x width, inches	26 x 38	30 x 40	30 x 52	34 x 58	36 x 64	42 x 66	42 x 74	46 x 80	58 x 82
Cooling coil face area, sq ft									
Extended/staggered large	3.9	4.8	6.6	8.5	10.7	13.5	15.4	18.3	21.9
Large	3.1	3.9	5.7	7.5	9.6	12.1	14.0	16.8	20.1
Extended/staggered medium	2.6	3.4	4.7	6.4	8.3	9.8	11.2	13.7	17.2
Medium	2.1	2.8	4.1	5.6	7.4	8.8	10.2	12.6	15.8
Small	N/A	2.3	3.3	4.7	6.4	7.7	8.9	11.2	14.4
Fan section—depth, inches									
Largest housed fan & motor avail. w/ top hor. dischg.	32	32	36	40	40	46	46	50	52
Largest inline fan and motor available	N/A	N/A	N/A	N/A	N/A	44	44	50	54
Largest belt drive plenum fan & motor available	N/A	N/A	N/A	N/A	34	42	42	48	52
Largest direct drive plenum fan & motor available	N/A	N/A	N/A	20	20	54	54	54	54
Largest twin fan and motor available	N/A	N/A	N/A	50	56	56	58	58	66
Largest 1 x 3 fan array and motor available	N/A	N/A	N/A	N/A	N/A	N/A	N/A	40	40
Largest 2 x 2 fan array and motor available	N/A	N/A	N/A	N/A	N/A	N/A	N/A	N/A	40
Largest 2 x 3 fan array and motor available	N/A	N/A	N/A	N/A	N/A	N/A	N/A	N/A	40
Mixing box—depth, inches									
Mixing box only	20	20	20	20	22	24	24	26	30
Mixing box with flat filter	24	24	24	24	26	28	28	30	34
Mixing box with angular filter	42	42	42	42	44	46	46	48	52
Economizer—depth, inches									
	40	40	40	40	44	48	48	52	60
Blender—depth, inches									
Largest Kees	18	20	24	26	28	34	36	38	42
Largest Blender Products IV	18	22	26	30	34	38	40	46	48
Side load filter sections—depth, inches									
Flat 2" and 4"	12	12	12	12	12	12	12	12	12
2" angular	32	30	30	30	30	30	30	30	30
Cartridge (12" deep w/2" pre-filter)	22	22	22	22	22	22	22	22	22
Bag (36" w/2" pre-filter)	42	42	42	42	42	42	42	42	42
Front load filter sections—depth, inches									
Cartridge (12" deep w/2" pre-filter)	16	16	16	16	16	16	16	16	16
Bag (36" w/2" pre-filter)	40	40	40	40	40	40	40	40	40
Face and bypass—depth, inches									
Internal	12	12	12	12	12	12	12	12	12
External	18	18	18	20	22	24	24	26	30
Coil sections—depth, inches									
Heating only (2-row water)	12	12	12	12	12	12	12	12	12
Cooling only (4-row water)	18	18	18	18	18	18	18	18	18
Cooling only (6-row water)	24	24	24	24	24	24	24	24	24
Cooling & reheat (12-row cooling & 1-row heating)	36	36	36	36	36	36	36	36	36
Vertical cooling only (6-row water)	30	30	30	30	36	36	36	36	42
Multizone coil section—depth, inches									
3-deck horizontal with dampers	N/A	N/A	40	42	42	52	52	54	56
Access sections—depth, inches									
16" deep	16	16	16	16	16	16	16	16	16
24" deep	24	24	24	24	24	24	24	24	24
30" deep	30	30	30	30	30	30	30	30	30
36" deep	36	36	36	36	36	36	36	36	36
42" deep	42	42	42	42	42	42	42	42	42
48" deep	48	48	48	48	48	48	48	48	48
54" deep	54	54	54	54	54	54	54	54	54
Diffuser—depth, inches									
With housed fan	10	10	10	12	12	16	16	16	16
With inline fan	N/A	N/A	N/A	N/A	N/A	18	18	18	22
Attenuator—depth, inches									
Short	40	40	40	40	40	40	40	40	40
Medium	52	52	52	52	52	52	52	52	52
Long	64	64	64	64	64	64	64	64	64
Supply or return plenum—depth, inches									
Top, bottom or end opening	14	16	16	18	20	22	22	24	28

* Based on typical industry sizes. Vision air handling units are available in 2 inch increments of height and width to fit the exact space requirements. Front load filter sections include 24" upstream plenum section with tread plate for heavy duty floor liner.

Commercial Indoor Air Handling Products

Physical Data—Vision

Quick Select Table* (continued)

Description	Unit size								
	025	030	035	040	050	065	080	085	090
Airflow range, cfm	7300–19,400	8500–22,500	10,000–26,500	11,500–31,000	15,000–40,000	20,000–54,000	21,500–57,500	23,100–61,600	24,600–65,600
cfm @ 500 ft/min through large face area coil	12,150	14,150	16,700	19,300	24,500	33,300	35,900	38,450	41,000
Height x width, inches	60 x 86	60 x 98	66 x 102	68 x 116	80 x 120	92 x 136	98 x 136	104 x 136	110 x 136
Cooling coil face area, sq ft									
Extended/staggered large	27.4	31.9	37.1	42.9	58.0	76.9	82.0	87.1	92.2
Large	24.3	28.3	33.4	38.6	49.0	66.6	71.8	76.9	82.0
Extended/staggered medium	21.3	24.8	29.7	34.3	40.1	61.5	61.5	66.6	71.8
Medium	18.2	21.2	24.1	30.0	35.7	51.2	51.2	56.4	61.5
Small	16.7	19.5	22.3	27.9	31.2	46.1	46.1	51.2	56.4
Fan section—depth, inches									
Largest housed fan & motor avail. w/ top hor. dischg.	58	58	58	70	80	92	92	92	92
Largest inline fan and motor available	64	64	70	70	90	96	96	96	96
Largest belt drive plenum fan & motor available	56	58	62	62	70	82	82	82	82
Largest direct drive plenum fan & motor available	66	78	84	86	86	86	N/A	N/A	N/A
Largest twin fan and motor available	66	74	82	82	82	N/A	N/A	N/A	N/A
Largest 1 x 3 fan array and motor available	40	40	46	52	52	52	52	52	52
Largest 2 x 2 fan array and motor available	40	40	46	52	52	58	62	64	64
Largest 2 x 3 fan array and motor available	40	40	46	52	52	52	52	52	52
Mixing box—depth, inches									
Mixing box only	32	32	36	36	40	46	50	54	56
Mixing box with flat filter	36	36	40	40	44	50	54	58	60
Mixing box with angular filter	54	54	58	58	62	68	72	76	78
Economizer—depth, inches									
	64	64	72	72	80	92	100	108	112
Blender—depth, inches									
Largest Kees	46	48	58	58	68	76	80	84	84
Largest Blender Products IV	52	60	64	70	74	88	88	92	92
Side load filter sections—depth, inches									
Flat 2" and 4"	12	12	12	12	12	12	12	12	12
2" angular	32	32	32	32	32	32	32	32	32
Cartridge (12" deep w/2" pre-filter)	22	22	22	22	22	22	22	22	22
Bag (36" w/2" pre-filter)	42	42	42	42	42	42	42	42	42
Front load filter sections—depth, inches									
Cartridge (12" deep w/2" pre-filter)	16	16	16	16	16	16	16	16	16
Bag (36" w/2" pre-filter)	40	40	40	40	40	40	40	40	40
Face and bypass—depth, inches									
Internal	12	12	12	12	12	12	12	12	12
External	32	32	34	38	44	50	54	56	58
Coil sections—depth, inches									
Heating only (2-row water)	12	12	12	12	12	12	12	12	12
Cooling only (4-row water)	18	18	18	18	18	18	18	18	18
Cooling only (6-row water)	24	24	24	24	24	24	24	24	24
Cooling & reheat (12-row cooling & 1-row heating)	36	36	36	36	36	36	36	36	36
Vertical cooling only (6-row water)	48	48	54	N/A	N/A	N/A	N/A	N/A	N/A
Multizone coil section—depth, inches									
3-deck horizontal with dampers	60	60	70	70	76	88	N/A	N/A	N/A
Access sections—depth, inches									
16" deep	16	16	16	16	16	16	16	16	16
24" deep	24	24	24	24	24	24	24	24	24
30" deep	30	30	30	30	30	30	30	30	30
36" deep	36	36	36	36	36	36	36	36	36
42" deep	42	42	42	42	42	42	42	42	42
48" deep	48	48	48	48	48	48	48	48	48
54" deep	54	54	54	54	54	54	54	54	54
Diffuser—depth, inches									
With housed fan	24	24	24	30	30	30	30	30	30
With inline fan	26	26	28	30	36	38	38	38	38
Attenuator—depth, inches									
Short	40	40	40	40	40	40	40	40	40
Medium	52	52	52	52	52	52	52	52	52
Long	64	64	64	64	64	64	64	64	64
Supply or return plenum—depth, inches									
Top, bottom or end opening	30	30	32	32	38	42	48	52	54

* Based on typical industry sizes. Vision air handling units are available in 2 inch increments of height and width to fit the exact space requirements. Front load filter sections include 24" upstream plenum section with tread plate for heavy duty floor liner.

Commercial Indoor Air Handling Products

Physical Data—Vision

Quick Select Table* (continued)

Description	Unit size				
	107	124	141	160	169
Airflow range, cfm	29,000–77,500	33,600–89,500	40,300–107,400	45,600–121,800	48,400–129,000
cfm @ 500 ft/min through large face area coil	48,500	55,900	67,100	76,200	80,600
Height x width, inches	108 x 168	108 x 192	122 x 192	122 x 216	122 x 228
Cooling coil face area, sq ft					
Large	96.88	111.9	134.25	152.25	161.25
Medium	77.5	89.5	96.96	109.96	116.46
Fan section—depth, inches					
Largest housed fan & motor avail. w/ top hor. discharge	92	92	92	92	92
Largest belt drive plenum fan and motor available	88	88	88	88	88
Largest direct drive plenum fan and motor available	94	94	94	94	94
Largest 1 x 3 fan array and motor available	58	62	62	64	64
Largest 2 x 2 fan array and motor available	64	64	64	64	64
Largest 2 x 3 fan array and motor available	58	62	62	64	64
Mixing box—depth, inches					
Mixing box only	64	64	72	72	72
Economizer—depth, inches					
	118	118	136	136	136
Blender—depth, inches					
Largest Kees	68	72	80	84	84
Largest Blender Products IV	78	86	92	92	92
Side load filter sections—depth, inches					
Flat 2" and 4"	22/24	22/24	22/24	22/24	22/24
Cartridge (12" deep w/2" pre-filter)	22/24	22/24	22/24	22/24	22/24
Bag (36" w/2" pre-filter)	44/46	44/46	44/46	44/46	44/46
Front load filter sections—depth, inches					
Cartridge (12" deep w/2" pre-filter)	20/20	20/20	20/20	20/20	20/20
Bag (36" w/2" pre-filter)	44/44	44/44	44/44	44/44	44/44
Face and bypass—depth, inches					
Internal	12	12	12	12	12
External	58	58	64	64	64
Coil sections—depth, inches					
Heating only (2-row water)	12	12	12	12	12
Cooling only (4-row water)	18	18	18	18	18
Cooling only (6-row water)	18	18	18	18	18
Cooling & reheat (12-row cooling & 1-row heating)	24	24	24	24	24
Access sections—depth, inches					
16" deep	16	16	16	16	16
24" deep	24	24	24	24	24
30" deep	30	30	30	30	30
36" deep	36	36	36	36	36
42" deep	42	42	42	42	42
48" deep	48	48	48	48	48
54" deep	54	54	54	54	54
Diffuser—depth, inches					
With housed fan	42	46	46	46	46
Attenuator—depth, inches					
Short	40	40	40	40	40
Medium	52	52	52	52	52
Long	64	64	64	64	64
Supply or return plenum—depth, inches					
Top, bottom or end opening	36	52	60	60	60

* Based on typical industry sizes. Vision air handling units are available in 2 inch increments of height and width to fit the exact space requirements. Front load filter sections include 24" upstream plenum section with tread plate for heavy duty floor liner.

Fan Array for Vision™ Air Handlers

- Plenty of back-up for critical installations. If one fan shuts down, the remaining can be selected and sized to provide design air flow
- Fan arrays can be placed close to coils and filters and still provide even air flow
- Noise occurs in higher octave bands that easier to attenuate
- Optional attenuating walls offered around each individual fan
- Smaller, lighter weight fan and motor assemblies
- Fans eliminate fan bearings, belts and sheaves. Less maintenance. Less lubrication required. Eliminate belt tensioning and replacement. Eliminate set screw tensioning which, if not done, can result in catastrophic failure
- Eliminate drive losses (typically 3-5%)
- Fan array section can be disassembled into smaller pieces

For more detail, refer to A/SP 31-306.

For the most current information, refer to DaikinApplied.com.



Model CAH—10,000 to 80,000 cfm (optimum)

Fan Array for Vision Air Handlers Features and Options



1 Multiple fan combinations are available and compliment the rest of Vision's fan flexibility

- Vision is also available with single or dual, belt drive or direct drive plenum fans to meet a variety of customer needs
- Multiple 16-30" diameter plenum fans are provided (quantity of fans varies per job). 1x3, 2x2, and 2x3 fan arrays generally provide optimum performance from 10,000 to 80,000 cfm
- A greater number of smaller fans generally compromises fan efficiency, requires excessively high fan rpm, more maintenance, and costs too much

2 Attenuating walls are offered around each individual fan

- Ducted noise reduction is typically reduced by 2-4 dB

3 Individual isolation dampers are offered for each fan

- Prevents air recirculation if a fan shuts down
- Manual dampers require less space and no air pressure drop
- Motorized dampers are available for critical installations

4 Daikin brand VFDs are offered

- VFDs are specially designed for HVAC applications
- Require less capacitance and generate less harmonics
- Robust diode bridge
- Many years of proven reliability
- Factory tested and configured for HVAC control applications

5 Single source power electrical panels are offered to reduce total installed cost

- Hinged access door
- Ventilation fan
- One VFD per fan is provided for 1x3 arrays. (Two VFDs shown for a 2x2 array)
- One VFD for every two fans is provided for other arrays
- Complete with ETL listing
- Terminal strip for all field control connections
- Optional through door disconnect
- Motor overload protection for each fan
- Circuit breakers for short circuit protection

Condensing Unit/Condenser/Fluid Cooler Product Summary Chart

Model:

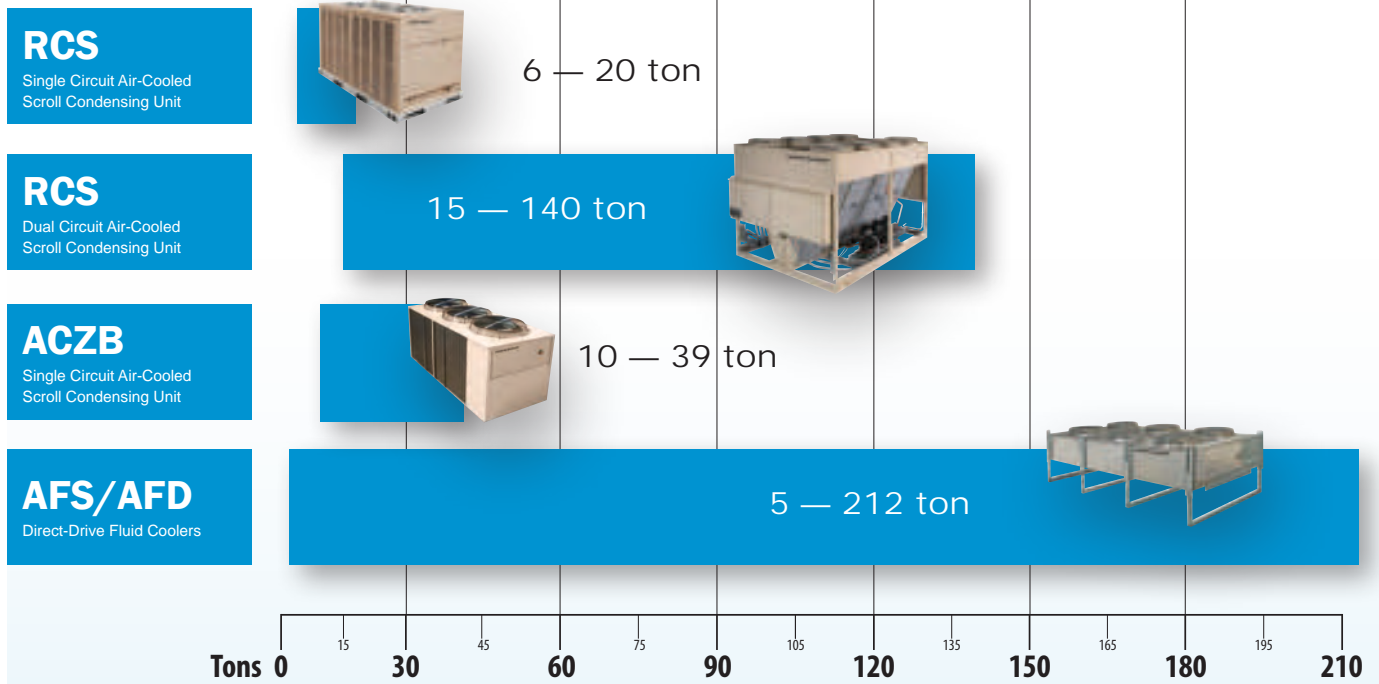

Model:

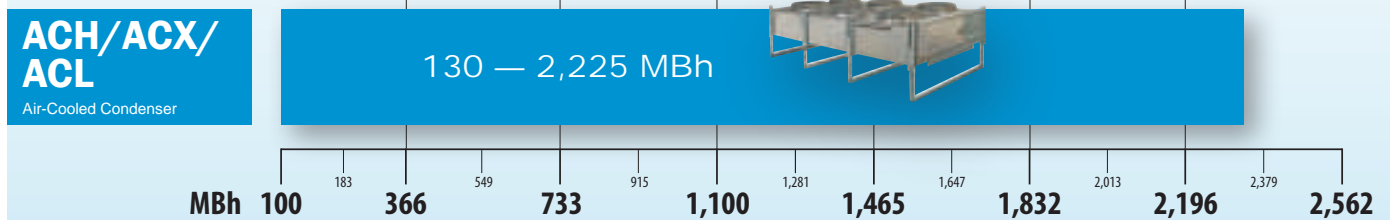

Condensing Units/
Condensers/Fluid Coolers

Single Circuit Air-Cooled Scroll Condensing Units—6 to 20 Tons

- Competitive price
- Prepainted exterior cabinet panels pass 1000-hour ASTM B 117 salt spray test for durability
- Vertical air discharge condenser fans for quiet operation
- Scroll compressors provide maximum dependability, efficiency and quiet operation
- Compatible with field supplied WYRG thermostats
- R-410A refrigerant
- Superior EER from 12.0–12.9

For more detail, refer to Catalog 223.

For the most current information, refer to DaikinApplied.com.



Model RCS—6.5 to 7.5 tons



Model RCS—10 to 12 tons



Model RCS—15 to 20 tons

Condensing Units/Condensers/Fluid Coolers

Physical Data—Scroll Condensing Units

RCS 06F through 20F, R-410A

Model	RCS						
	06F Single	07F Single	10F Single	11F Tandem	12F Tandem	15F Tandem	20F Tandem
Capacity and weight							
Capacity (tons) [kW]	6.5 [22.9]	7.5 [26.4]	10 [35.2]	10 [35.2]	12 [42.2]	15 [52.8]	20 [70.3]
Number of circuits	1	1	1	1	1	1	1
Operating weight	264 [119.8]	283 [128.4]	501 [227.3]	586 [265.8]	650 [294.8]	746 [338.4]	952 [431.8]
Shipping weight	287 [130.2]	306 [138.8]	541 [245.4]	626 [284.0]	690 [313.0]	786 [356.5]	992 [450.0]
Compressor							
Quantity	1	1	1	2	2	2	2
Type	Scroll	Scroll	Scroll	Scroll	Scroll	Scroll	Scroll
RPM	3500	3500	3500	3500	3500	3500	3500
Refrigerant charge R410A oz. [g]	178 [5046]	242 [6861]	339 [9661]	300 [8505]	378 [10,716]	506 [14,345]	655 [18,569]
Condenser fans							
Quantity	1	1	2	2	2	3	3
CFM [L/s]	4700 [2218]	4700 [2218]	8100 [3822]	8100 [3822]	8100 [3882]	12,000 [5663]	12,000 [5663]
Diameter (in.) [mm]	24 [610]	24 [610]	24 [610]	24 [610]	24 [610]	24 [610]	24 [610]
Drive	Direct	Direct	Direct	Direct	Direct	Direct	Direct
Motor horsepower each [W]	1/3 [249]	1/3 [249]	1/3 [249]	1/3 [249]	1/3 [249]	1/3 [249]	1/3 [249]
Type	PSC	PSC	PSC	PSC	PSC	PSC	PSC
RPM	1075	1075	1075	1075	1075	1075	1075
Condenser coil							
Quantity	1	1	2	2	2	2	2
Rows	1-1/2	2	2	2	2	2	3
Fins per inch	20	22	18	22	22	22	22
Sq. ft. [m ²]	23.0 [2.14]	23.0 [2.14]	27.0 [2.51]	27.0 [2.51]	33.9 [3.05]	40.38 [3.75]	40.38 [3.75]
Fins/tubes	Aluminum/Copper						
Cabinet							
Finish	Powder Coat						
Sheet metal	Galvanized						
Gauge (nominal) top	20	20	20	20	20	20	20
Sides	20	20	20	20	20	20	20
Base rails	14	14	14	14	14	14	14
Refrigerant connection							
Vapor sweat (in.) [mm]	1-1/8 [29]	1-1/8 [29]	1-3/8 [35]	1-3/8 [35]	1-3/8 [35]	1-3/8 [35]	1-5/8 [41.3]
Liquid sweat (in.) [mm]	1/2 [13]	1/2 [13]	5/8 [16]	5/8 [16]	5/8 [16]	5/8 [16]	7/8 [22]

Condensing Units/Condensers/Fluid Coolers

Electrical Data—Scroll Condensing Units

RCS 06F through 20F, R-410A

Model	RCS											
	06F (Single)			07F (Single)			10F (Single)			11F (Tandem)		
Compressor motor												
Electrical characteristics	208/230-3-60	460-3-60	575-3-60	208/230-3-60	460-3-60	575-3-60	208/230-3-60	460-3-60	575-3-60	208/230-3-60	460-3-60	575-3-60
Operating current												
Rated load amps (each) ¹	18.6	9.0	7.4	25.6	12.2	9.0	30.1	16.7	12.2	17.6	9.6	6.1
Locked rotor amps (each) ¹	156	75	54	156	100	78	225	114	80	135	64	40
Condenser fan motors												
Volt and phase	208/230-1	460-1	575-1	208/230-1	460-1	575-1	208/230-1	460-1	575-1	208/230-1	460-1	575-1
Full load amps (each)	2.2	1.3	1.0	2.2	1.3	1.0	2.2	1.3	1.0	2.2	1.3	1.0
System characteristics												
Unit full load amps ²	20.8	10.3	8.4	27.8	13.5	10.0	34.5	19.3	14.2	39.6	21.8	14.4
Minimum circuit ampacity	31.0	15.0	11.0	34.0	17.0	13.0	43.0	24.0	18.0	45.0	25.0	16.0
Maximum fuse size (amps) or HACR circuit breaker ampacity ³	50	25	15	50	25	20	60	40	25	60	30	20
Disconnect size	60	30	30	60	30	30	60	40	25	60	30	30

Model	RCS								
	12F (Tandem)			15F (Tandem)			20F (Tandem)		
Compressor motor									
Electrical characteristics	208/230-3-60	460-3-60	575-3-60	208/230-3-60	460-3-60	575-3-60	208/230-3-60	460-3-60	575-3-60
Operating current									
Rated load amps (each) ¹	22.4	10.6	7.7	25.0	12.2	9.0	33.3	17.9	12.8
Locked rotor amps (each) ¹	149	75	54	164	100	78	239	125	80
Condenser fan motors									
Volt and phase	208/230-1	460-1	575-1	208/230-1	460-1	575-1	208/230-1	460-1	575-1
Full load amps (each)	2.2	1.3	1.0	2.2	1.3	1.0	2.2	1.3	1.0
System characteristics									
Unit full load amps ²	49.2	23.8	17.4	56.6	28.3	21.0	73.2	39.2	28.6
Minimum circuit ampacity	56.0	27.0	20.0	64.0	32.0	24.0	83.0	44.0	32.0
Maximum fuse size (amps) or HACR circuit breaker ampacity ³	70	35	25	80	40	30	110	60	40
Disconnect size	60	30	30	100	60	60	200	60	60

1. Each compressor

2. Conditions at 45° suction and 95° ambient

3. Local codes take precedent over recommended fuse size

Single Circuit Air-Cooled Scroll Condensing Units—10 to 39 Tons

- Efficient—Up to 10.9 EER at full load and up to 13.6 EER at part load (IPLV)
- Quiet—All dBA ratings are tested in accordance with AHRI Standard 370; less acoustical treatment can lower your project cost
- Reliable—Scroll compressors have fewer moving parts
- Controls flexibility—MicroTech® II controls with our Open Choices™ feature for easy integration with the BAS of your choice
- Optional low ambient operation range down to 0°F
- R-407C refrigerant

For more detail, refer to Catalog 616.

For the most current information, refer to DaikinApplied.com.



Model ACZ-B—10 to 39 tons



Condensing Units/Condensers/Fluid Coolers

Physical Data—Air-Cooled Scroll Condensing Units, Single Circuit

ACZ 010BS through 020BS, R-407C

Physical data	ACZ model number			
	010BS	013BS	016BS	020BS
Basic data				
Nominal Tons	10	13	16	20
Number of refrigerant circuits	1	1	1	1
Unit operating charge, R-407C, lb (kg)	22.0 (10.0)	22.0 (10.0)	24.0 (10.9)	31.0 (14.1)
Cabinet dimensions,				
L x W x H, in (mm)	73.6 x 46.3 x 50.8 (1869 x 1176 x 1289)			
Unit operating weight, lb (kg)	1015 (461)	1015 (461)	1090 (495)	1190 (541)
Unit shipping weight, lb (kg)	1000 (454)	1000 (454)	1065 (484)	1150 (523)
Add'l weight if copper finned coils, lb (kg) R-407C	176 (80.0)	176 (80.0)	176 (80.0)	264 (120.0)
Compressors				
Type	Scroll	Scroll	Scroll	Scroll
Nominal horsepower	4.0 / 4.0	6.0 / 6.0	7.5 / 7.5	9.0 / 9.0
Oil charge per compressor of a tandem set, oz (g)	57 (1616)	60 (1701)	140 (3969)	140 (3969)
Capacity reduction steps—percent of compressor displacement				
Standard staging	0 – 50 – 100	0 – 50 – 100	0 – 50 – 100	0 – 50 – 100
Condensers—high efficiency fin and tube type with integral subcooling				
Coil face area, ft ² (m ²)	30.3 (2.8)	30.3 (2.8)	30.3 (2.8)	30.3 (2.8)
Finned height x finned length, in (mm)	84 x 52 (2134 x 1321)	84 x 52 (2134 x 1321)	84 x 52 (2134 x 1321)	84 x 52 (2134 x 1321)
Fins per inch x rows deep: R-407C	16 x 2	16 x 2	16 x 2	16 x 3
Pumpdown capacity, lb (kg)	35.3 (16.0)	35.3 (16.0)	35.3 (16.0)	50.3 (22.8)
Condenser fans—direct drive propeller type				
Number of fans—fan diameter, in (mm)	2–26 (660)	2–26 (660)	2–26 (660)	2–26 (660)
Number of motors—hp (kW)	2–1.0 (0.75)	2–1.0 (0.75)	2–1.0 (0.75)	2–1.0 (0.75)
Fan and motor rpm, 60 Hz	1140	1140	1140	1140
60 Hz total unit airflow, cfm (L/s)	13,950 (6584)	13,950 (6584)	13,950 (6584)	12,000 (5664)

1. Nominal capacity based on 95°F ambient air and 50°F saturated suction temperature (SST).
2. Operating charge is for the condensing unit only. Refrigerant lines and evaporator charge must be added.
3. Except for 380V/60 and 575V/60, hp = 2.0.

Condensing Units/Condensers/Fluid Coolers

Physical Data—Air-Cooled Scroll Condensing Units, Single Circuit

ACZ 025BS through 039BS, R-407C

Physical data	ACZ model number			
	025BS	028BS	033BS	039BS
Basic data				
Nominal tons	25	28	33	39
Number of refrigerant circuits	1	1	1	1
Unit operating charge, R-407C, lb (kg)	34.0 (15.4)	36.0 (16.3)	47.0 (21.3)	50.0 (22.7)
Cabinet dimensions,				
L x W x H, in (mm)	106.2 x 46.3 x 50.8 (2697 x 1176 x 1289)			
Unit operating weight, lb (kg)	1470 (667)	1490 (676)	1760 (799)	1960 (890)
Unit shipping weight, lb (kg)	1580 (717)	1600 (726)	1890 (858)	2090 (949)
Add'l weight if copper finned coils, lb (kg) R-407C	426 (194)	426 (194)	435 (197)	435 (197)
Compressors				
Type	Scroll	Scroll	Scroll	Scroll
Nominal horsepower	12.0 / 12.0	13.0 / 13.0	15.0 / 15.0	20.0 / 20.0
Oil charge per compressor of a tandem set, oz (g)	110 (3119)	110 (3119)	110 (3119)	158 (4479)
Capacity reduction steps—percent of compressor displacement				
Standard staging	0 – 50 – 100	0 – 50 – 100	0 – 50 – 100	0 – 50 – 100
Condensers—high efficiency fin and tube type with integral subcooling				
Coil face area, ft ² (m ²)	49.0 (4.6)	49.0 (4.6)	58.3 (5.4)	58.3 (5.4)
Finned height x finned length, in (mm)	84 x 84 (2134 x 2134)	84 x 84 (2134 x 2134)	100 x 84 (2545 x 2134)	100 x 84 (2545 x 2134)
Fins per inch x rows deep: R-407C	16 x 2	16 x 2	16 x 3	16 x 3
Pumpdown capacity, lb (kg)	53.1 (24.0)	53.1 (24.0)	90.7 (41.1)	92.8 (42.0)
Condenser fans—direct drive propeller type				
Number of fans—fan diameter, in (mm)	3–26 (660)	3–26 (660)	3–26 (660)	3–26 (660)
Number of motors—hp (kW)	3–1.0 (0.75)	3–1.0 (0.75)	3–1.0 (0.75)	3–1.0 (0.75)
Fan and motor rpm, 60 Hz	1140	1140	1140	1140
60 Hz total unit airflow, cfm (L/s)	20,925 (9877)	20,925 (9877)	19,800 (9346)	19,800 (9346)

1. Nominal capacity based on 95°F ambient air and 50°F saturated suction temperature (SST).
2. Operating charge is for the condensing unit only. Refrigerant lines and evaporator charge must be added.
3. Except for 380V/60 and 575V/60, hp = 2.0.

Dual Circuit Air-Cooled Scroll Condensing Units—15 to 140 Tons

- Efficient—Up to 12.1 EER at full load
- Reliable—Scroll compressors have fewer moving parts; two circuits on all size units provide backup cooling
- Optional low ambient operation range down to 0°F
- R-410A refrigerant

For more detail, refer to **Catalog 222**.

For the most current information, refer to **DaikinApplied.com**.



Model RCS—15 to 140 tons

Quiet condenser option

With this option, sound power at the unit is reduced by an average of 7 dB when compared to standard units.

- Quiet condensers are specially engineered to reduce radiated noise and improve condenser fan efficiency
- Aerodynamic, airfoil, sickle-shaped blades and bell mouth orifices improve fan efficiency
- Each fan includes seven blades complete with serrated trailing edges and special blade tip to break up turbulence and reduce noise
- Individual compressor sound blankets are provided to reduce noise



Condensing Units/Condensers/Fluid Coolers

Physical Data—Air Cooled Scroll Condensing Units, Dual Circuit

RCS 015D through 140D, R-410A

Model	RCS								
	015D	020D	025D	030D	035D	040D	045D	050D	062D
Basic Data									
Number of refrigeration circuits	2	2	2	2	2	2	2	2	2
Unit operating charge (lb) ¹ per circuit	6.5	7.1	8.0	9.6	10.4	10.8	12.6	12.6	12.7
Operating weight (lb)	1492	1577	1581	1986	2203	2229	2305	2425	2552
Compressors									
Qty.- hp	2 – 7	2 – 4.5, 1 – 10	2 – 5.5, 1 – 11.5	2 – 6, 1 – 13	4 – 7.5	4 – 8.5	4 – 10	4 – 11.5	4 – 13
Capacity control	100-50	100-78- 55-22	100-78- 55-22	100-78- 55-22	100-75- 50-25	100-75- 50-25	100-75- 50-25	100-75- 50-25-0	100-75- 50-25-0
Condenser Fans									
Qty. - diameter	2 – 26"	2 – 26"	2 – 26"	4 – 26"	4 – 26"	4 – 26"	4 – 26"	4 – 26"	6 – 26"
Qty. - hp	2 – 1.0	2 – 1.0	2 – 1.0	4 – 1.0	4 – 1.0	4 – 1.0	4 – 1.0	4 – 1.0	6 – 1.0

Model	RCS							
	072D	080D	092D	100D	110D	120D	125D	140D
Basic Data								
Number of refrigeration circuits	2	2	2	2	2	2	2	2
Unit operating charge (lb) ¹ per circuit	15.1	19.0	19.2	19.2	29.1	29.1/34.7	32.3	32.3/37.5
Operating weight (lb)	3496	3603	3828	3764	4277	4858	5439	5619
Compressors								
Qty.- hp	6 – 10	6 – 11.5	6 – 13	3 – 13, 3 – 15	6 – 15	3 – 15, 3 – 20	6 – 20	3 – 20, 3 – 25
Capacity control	100-83-67- 50-33-17-0	100-83-67- 50-33-17-0	100-83-67- 50-33-17-0	100-81-67- 48-33-15-0	100-84-67- 50-33-17-0	100-81-67- 48-33-15-0	100-84-67- 50-33-17-0	100-81-67- 48-33-15-0
Condenser Fans								
Qty. - diameter	8 – 26"	6 – 26"	9 – 26"	9 – 26"	8 – 26"	9 – 26"	10 – 26"	12 – 26"
Qty. - hp	8 – 1.0	6 – 1.0	9 – 1.0	9 – 1.0	8 – 1.0	9 – 1.0	10 – 1.0	12 – 1.0

1. Unit shipped with dry nitrogen holding charge.

Condensing Units/Condensers/Fluid Coolers

Compressor Rated Load Amps

RCS 015D through 140D

Unit Size	Voltage	MCA Total	MOC PD Total	Standard Fuse Size
015D	208	70	98	90
	230	64	89	80
	460	31	44	40
	575	25	34	30
020D	208	101	116	125
	230	92	105	125
	460	46	52	60
	575	34	39	40
025D	208	125	142	175
	230	113	129	150
	460	49	58	60
	575	39	44	50
030D	208	139	156	175
	230	127	143	175
	460	59	68	80
	575	48	53	60
035D	208	155	187	175
	230	141	171	150
	460	70	85	80
	575	59	71	70
040D	208	159	193	175
	230	146	176	175
	460	79	96	90
	575	59	71	70
045D	208	195	238	225
	230	178	217	200
	460	90	109	100
	575	66	80	70
050D	208	20	273	250
	230	193	241	225
	460	98	117	110
	575	71	87	80
060D	208	257	314	300
	230	226	227	250
	460	114	137	125
	575	91	111	110
062D	208	265	322	300
	230	230	281	250
	460	122	145	125
	575	95	115	110

Unit Size	Voltage	MCA Total	MOC PD Total	Standard Fuse Size
070D	208	288	330	300
	230	251	289	250
	460	144	163	150
	575	97	111	110
075D	208	376	433	400
	230	327	378	350
	460	165	188	175
	575	126	146	125
080D	208	357	410	400
	230	313	361	350
	460	144	163	150
	575	110	126	125
092D	208	392	443	400
	230	257	388	350
	460	162	199	175
	575	140	158	150
100D	208	410	474	450
	230	358	416	400
	460	196	225	200
	575	150	174	150
110D	208	433	495	450
	230	393	435	400
	460	197	242	225
	575	162	185	175
120D	208	502	586	500
	230	457	516	500
	460	218	271	250
	575	179	207	200
125D	208	567	651	600
	230	497	573	500
	460	258	292	250
	575	195	223	200
140D	208	625	724	700
	230	546	636	600
	460	299	344	300
	575	218	253	250

Air-Cooled Condensers—130 to 2,225 MBh

- Model ACH offers most capacity per dollar
- Models ACL and ACX provide excellent efficiency and sound ratings at a moderate price
- Easy-to-install design reduces installation cost and time
- Fan motors and blades have been selected for the best performance at minimum sound levels
- High efficiency condenser coil designed for optimum performance
- Condenser coils are designed to operate with R-134a, R-407C, and R-410A

For more detail, refer to Catalog A–C Cond.
For the most current information, refer to DaikinApplied.com.



Models ACH/ACX/ACL—130 to 2,225 MBh

Condensing Units/Condensers/Fluid Coolers

Air-Cooled Condenser Dimensions (shown in inches)

End Views

Side Views

Single Row of Fans

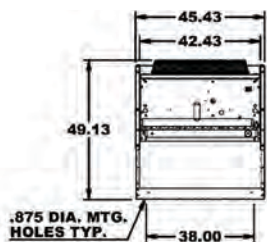

Double Row of Fans

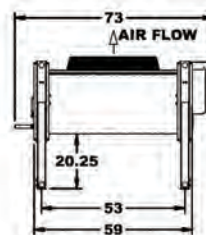
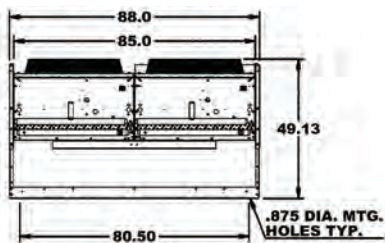

1 x 1

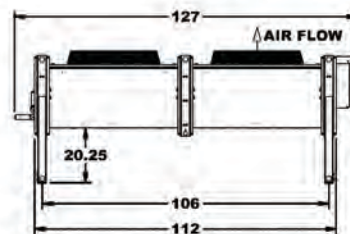

1 x 1
2 x 2

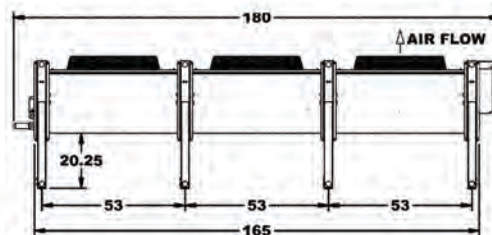

1 x 3
2 x 3

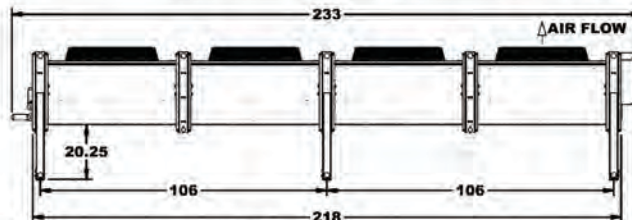

1 x 4
2 x 4

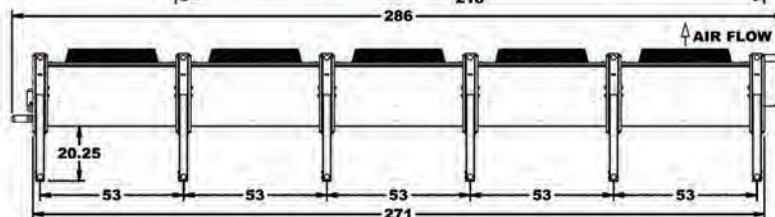

1 x 5
2 x 5

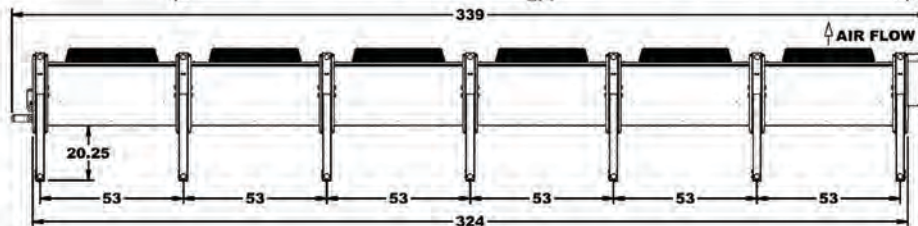

1 x 6
2 x 6

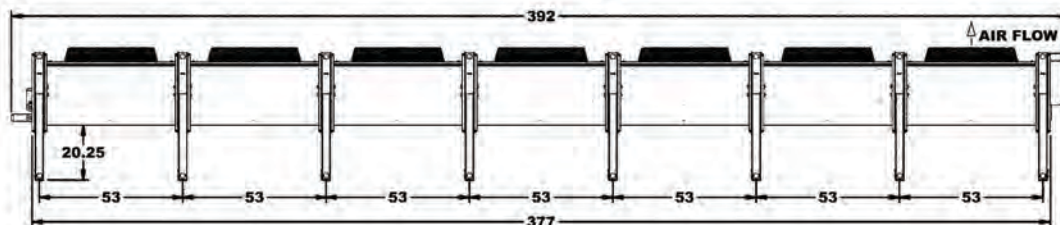

1 x 7
2 x 7

Condensing Units/
Condensers/Fluid Coolers

Condensing Units/Condensers/Fluid Coolers

Physical Data—Air-Cooled Condensers

Model 014S through 225D

Model number	Model ACH				Model ACL				Model ACX			
	Fans/Row	CFM	Conn. (in)	Weight (lbs)	Fans/Row	CFM	Conn. (in)	Weight (lbs)	Fans/Row	CFM	Conn. (in)	Weight (lbs)
014S	1	9900	1-3/8	330	1	8400	1-3/8	330	1	7600	1-3/8	330
016S	1	9500	1-3/8	360	1	8000	1-3/8	360	1	7300	1-3/8	360
020S	2	20,500	1-3/8	580	2	17,500	1-3/8	580	2	15,900	1-3/8	580
025S	2	19,800	1-5/8	630	2	16,700	1-5/8	630	2	15,200	1-5/8	630
030S	2	19,000	2-1/8	680	2	16,100	2-1/8	680	2	14,700	2-1/8	680
040S	3	29,700	2-1/8	930	3	25,100	2-1/8	930	3	22,900	2-1/8	930
050S	3	28,500	2-1/8	1000	3	24,100	2-1/8	1000	3	22,000	2-1/8	1000
055S	4	38,600	2-1/8	1210	4	32,800	2-1/8	1210	4	29,800	2-1/8	1210
060S	4	37,000	2-5/8	1310	4	31,200	2-5/8	1310	4	28,400	2-5/8	1310
070S	5	48,300	2-5/8	1510	5	41,000	2-5/8	1510	5	37,300	2-5/8	1510
080S	5	46,200	2-5/8	1640	5	39,100	2-5/8	1640	5	35,500	2-5/8	1640
100S	6	55,400	2 5/8	1950	6	46,900	2-5/8	1950	6	42,600	2-5/8	1950
110S	7	64,700	(2) 2-5/8	2240	7	54,700	(2) 2-5/8	2240	7	49,700	(2) 2-5/8	2240
040D	2	41,000	(2) 1-3/8	1240	2	35,000	(2) 1-3/8	1240	2	31,700	(2) 1-3/8	1240
050D	2	39,600	(2) 1-5/8	1340	2	33,500	(2) 1-5/8	1340	2	30,500	(2) 1-5/8	1340
060D	2	38,100	(2) 2-1/8	1440	2	32,100	(2) 2-1/8	1440	2	29,300	(2) 2-1/8	1440
080D	3	59,400	(2) 2-1/8	1990	3	50,200	(2) 2-1/8	1990	3	45,700	(2) 2-1/8	1990
100D	3	57,100	(2) 2-1/8	2140	3	48,200	(2) 2-1/8	2140	3	44,000	(2) 2-1/8	2140
110D	4	77,200	(2) 2-1/8	2630	4	65,600	(2) 2-1/8	2630	4	59,700	(2) 2-1/8	2630
130D	4	73,900	(2) 2-5/8	2830	4	62,500	(2) 2-5/8	2830	4	56,800	(2) 2-5/8	2830
140D	5	96,500	(2) 2-5/8	3290	5	82,000	(2) 2-5/8	3290	5	74,600	(2) 2-5/8	3290
160D	5	92,400	(2) 2-5/8	3540	5	78,100	(2) 2-5/8	3540	5	71,000	(2) 2-5/8	3540
200D	6	110,900	(2) 2-5/8	4230	6	93,700	(2) 2-5/8	4230	6	85,200	(2) 2-5/8	4230
225D	7	129,400	(4) 2-5/8	4910	7	109,300	(4) 2-5/8	4910	7	99,400	(4) 2-5/8	4910

Direct Drive Fluid Coolers—5 to 212 Tons

- Specifically engineered for outdoor installation with heavy gauge galvanized steel construction to resist corrosion
- Factory-installed lifting brackets and single point field wiring reduce installation costs and time
- Coils are fabricated with corrugated aluminum fins and staggered copper tubes for optimum heat transfer
- Models AFS 023 through AFD 212 use the Daikin patented Floating Tube design to virtually eliminate leaks at the tube sheets
- Fan motor and blade assemblies undergo dynamic stress testing to provide low vibration levels and to improve the reliability of the air moving assembly

For more detail, refer to Catalog 607.

For the most current information, refer to DaikinApplied.com.



Model AFS 005 through AFS 107—5 to 107 tons

Model AFD 046 through AFD 212—46 to 212 tons

Condensing Units/Condensers/Fluid Coolers

Physical Data—Direct Drive Fluid Coolers

Model 005 through 021

AFS Model	Fan data		Operating Charge (Gal)	Approximate net weight (lb ¹)	Approx. shipping weight (lb)	Approx. Operating Weight (lb)
	Fan config.	Fan diameter				
005	1 x 1	24	2.5	180	325	240
008	1 x 1	26	3.8	260	380	330
010	1 x 2	24	4.0	450	600	537
012	1 x 2	26	4.0	470	620	557
014	1 x 2	26	4.9	510	650	615
016	1 x 2	26	6.1	530	680	635
021	1 x 3	26	6.6	550	725	698

1. Net weight is dry unit only.

Model 023 through 212

Model	Fan Data			Approx. Operating Charge (gal)	Approx. Net Weight (lbs)	Approx. Shipping Weight (lbs)	Approx. Operating Weight (lbs)
	Fan Config.	Number of Fans	cfm				
AFS single row of fans							
023	1 x 2	2	23,000	6.7	730	800	788
027	1 x 2	2	23,200	9.2	790	840	870
031	1 x 2	2	21,900	9.2	790	860	870
035	1 x 2	2	20,700	11.8	889	950	992
041	1 x 3	3	34,800	13.0	1190	1280	1303
045	1 x 3	3	32,900	13.0	1210	1300	1323
049	1 x 3	3	31,800	16.7	1240	1330	1385
053	1 x 4	4	46,400	16.7	1580	1690	1725
061	1 x 4	4	43,900	16.7	1620	1730	1765
065	1 x 4	4	42,400	21.7	1650	1760	1839
071	1 x 4	4	41,500	21.7	1760	1870	1949
075	1 x 5	5	54,900	20.4	2000	2150	2177
079	1 x 5	5	54,800	26.6	2020	2150	2251
089	1 x 5	5	51,800	26.6	2200	2390	2431
097	1 x 6	6	65,800	31.6	2390	2610	2665
107	1 x 6	6	62,200	31.6	2630	2850	2905
AFD double row of fans							
046	2 x 2	4	46,000	13.5	1540	1730	1657
054	2 x 2	4	46,400	18.5	1580	1770	1741
060	2 x 2	4	43,900	18.5	1620	1820	1781
066	2 x 2	4	42,400	23.5	1650	1840	1854
070	2 x 2	4	41,500	23.5	1760	1950	1964
080	2 x 3	6	69,700	25.9	2360	2570	2585
086	2 x 3	6	67,000	25.9	2380	2620	2605
090	2 x 3	6	65,800	25.9	2420	2630	2645
098	2 x 3	6	63,600	33.4	2480	2690	2771
106	2 x 4	8	92,900	33.3	3150	3360	3440
120	2 x 4	8	87,800	33.3	3230	3420	3520
132	2 x 4	8	84,800	43.3	3300	3470	3677
140	2 x 4	8	83,000	43.3	3510	3730	3887
152	2 x 5	10	190,700	40.7	4040	4290	4394
162	2 x 5	10	109,700	53.1	3990	4270	4452
168	2 x 5	10	106,000	53.1	4130	4450	4592
178	2 x 5	10	103,700	53.1	4390	4680	4852
194	2 x 6	12	131,600	63.1	4790	5150	5339
202	2 x 6	12	127,200	63.1	4960	5330	5509
212	2 x 6	12	124,400	63.1	5270	5670	5819

1. Net weight is dry unit only.

2. Operating weight based on 50% ethylene glycol at 130°F.

3. All fans are 30 inches in diameter.

Condensing Units/Condensers/Fluid Coolers

Physical Data—Direct Drive Fluid Coolers

Sound Pressure

Model No.	Fans	Sound Pressure, dBa, 1140 RPM Fans				Sound Pressure, dBa, 830 RPM Fans			
		Distance from Side of Unit, ft.				Distance from Side of Unit, ft.			
		5	10	20	40	5	10	20	40
023, 027, 031, 035	1 × 2	77	74	69	65	69	65	61	56
041, 045, 049	1 × 3	79	76	71	67	71	67	63	58
053, 061, 065, 071,	1 × 4	80	77	72	68	72	68	64	59
075, 079, 089	1 × 5	81	78	73	69	73	69	65	60
097, 107	1 × 6	82	79	74	70	74	70	65	61
046, 054, 060, 066, 070	2 × 2	79	76	71	67	71	67	63	58
080, 086, 090, 098	2 × 3	81	78	73	69	73	69	65	60
106, 120, 132, 140	2 × 4	82	79	74	70	74	70	66	61
152, 162, 168, 178	2 × 5	83	80	75	71	75	71	67	62
194, 202, 212	2 × 6	84	81	76	72	76	72	68	63

Direct Drive Fluid Coolers—Dimensions

AFS 005 through AFS 021 with Vertical Flow

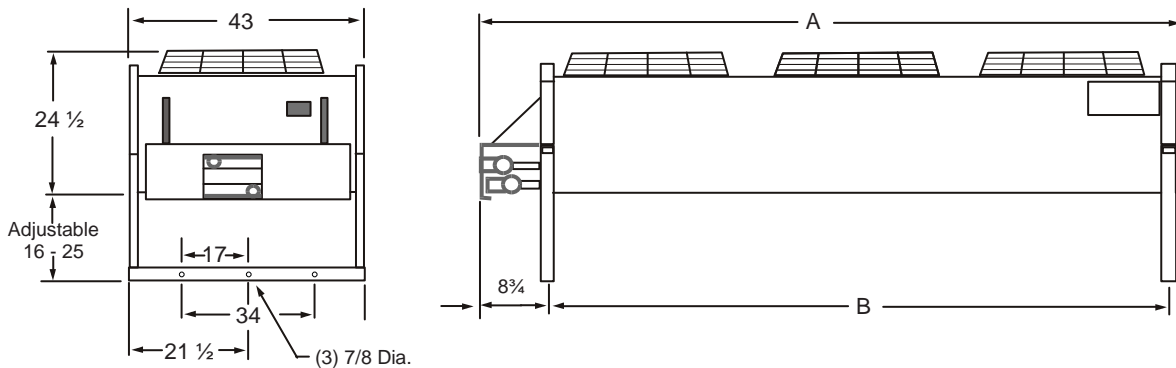

AFS 005 through AFS 021 with Horizontal Flow

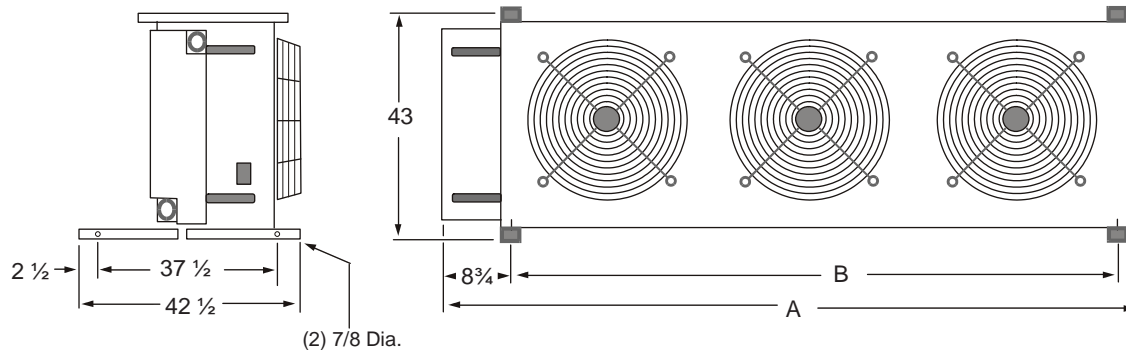

Notes:

Inlet is the top connection, outlet the bottom.
The electrical box is on the same end as the fluid connections with knockouts on the bottom and sides.

AFS Model	Number of Fans	Dim. A (in.)	Dim. B (in.)
005	1	39-3/4	30
008	1	49-3/4	40
010	2	69-3/4	60
012	2	69-3/4	60
014	2	89-3/4	80
016	2	89-3/4	80
021	3	129-3/4	120

Condensing Units/Condensers/Fluid Coolers

Air-Cooled Condenser Dimensions (shown in inches)

End Views

Side Views

AFS 023 through AFS 107
Single Row of Fans

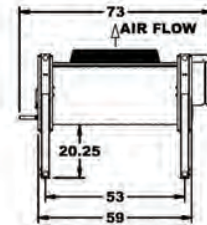
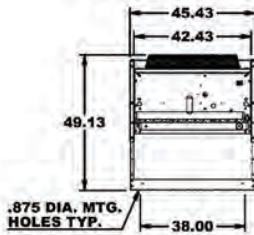

1 x 1

AFD 046 through AFD 212
Double Row of Fans

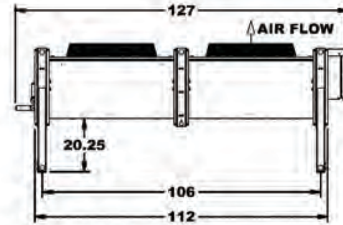
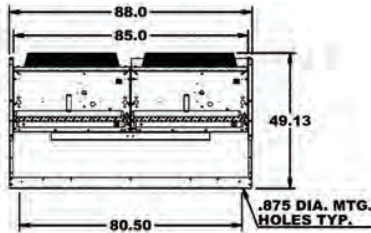

1 x 1
2 x 2

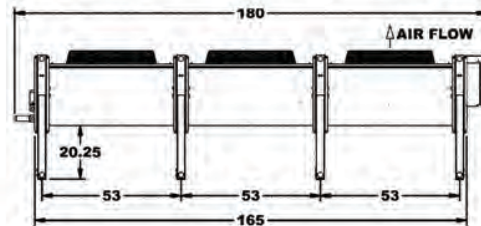

1 x 3
2 x 3

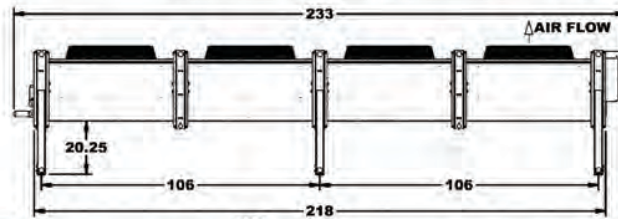

1 x 4
2 x 4

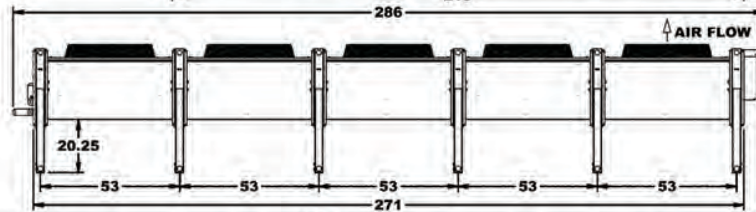

1 x 5
2 x 5

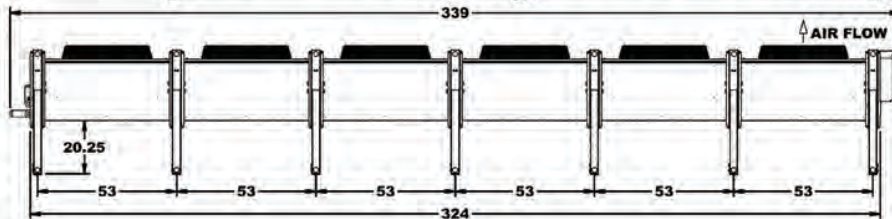

1 x 6
2 x 6

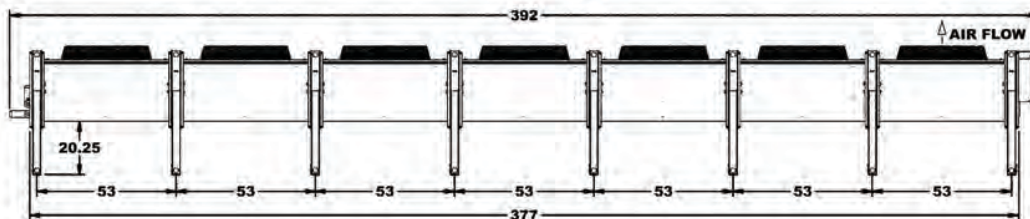

1 x 7
2 x 7

Air-Cooled Chiller Product Summary Chart

Model:

R-407C

AGZ-B

Air-cooled Scroll Compressor Chiller



EER range: up to 13.9 IPLV

10 — 34 tons

R-410A

AGZ-D

Air-cooled Scroll Compressor Chiller



EER range: up to 15.6 IPLV

25 — 190 tons

Remote evaporator and pump package available

R-134a

AGS

Air-cooled Screw Compressor Chiller

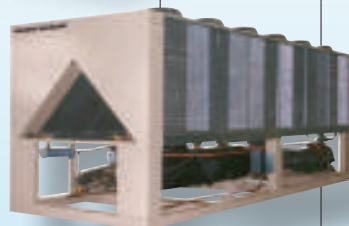

EER range: 9.6—10.5 IPLV

140 — 200 tons

Remote evaporator and pump package available on certain models

R-134a

AWS

Pathfinder®
Air-cooled Screw Compressor Chiller



EER range: up to 19.4 IPLV

170 — 550 tons

Optional VFD and remote evaporator available



Air-Cooled Chillers

Air-Cooled Chillers

Air-Cooled Scroll Compressor Chillers—25 to 190 Tons

- Efficient—Meets or exceeds ASHRAE Standard 90.1
- Up to 10.3 EER at full load and up to 15.6 EER at part load (IPLV)
- Quiet—As low as 60 dBA without any optional acoustic treatment
- Controls flexibility—MicroTech® III controls with our Open Choices™ feature for easy integration with the BAS of your choice
- Optional low ambient operation range down to -10°F (-23°C)
- Remote evaporators available
- Pump package option

For more detail, refer to Catalog 611.

For the most current information, refer to DaikinApplied.com.



Model AGZ-D—25 to 190 tons,
R-410A, Dual Circuit



Air-Cooled Chillers

Physical Data—Air-Cooled Scroll Compressor Chiller

AGZ 025D through AGZ 045D, Packaged

Data	AGZ025DH		AGZ030DH		AGZ035DH		AGZ040DH		AGZ045DH	
	Circuit 1	Circuit 2	Circuit 1	Circuit 2	Circuit 1	Circuit 2	Circuit 1	Circuit 2	Circuit 1	Circuit 2
Basic Data										
Unit Capacity @ AHRI Conditions (See Note 1), Tons (kW)	27 (96)		32 (111)		35 (123)		38 (133)		43 (150)	
Number of Refrigerant Circuits	2		2		2		2		2	
Unit Operating Charge, R-410A, lbs (kg)	28 (13)	28 (13)	32 (15)	32 (15)	32 (15)	32 (15)	39 (17)	39 (17)	44 (20)	44 (20)
Cabinet Dimensions, LxWxH, in. (mm)	94.4x88.0x100.4 (2398x2235x2550)		94.4x88.0x100.4 (2398x2235x2550)		94.4x88.0x100.4 (2398x2235x2550)		94.4x88.0x100.4 (2398x2235x2550)		94.4x88.0x100.4 (2398x2235x2550)	
Unit Operating Weight, lbs (kg)	3163 (1435)		3195 (1449)		3205 (1454)		3285 (1490)		3445 (1563)	
Unit Shipping Weight, lbs (kg)	3148 (1428)		3180 (1442)		3185 (1445)		3265 (1481)		3420 (1551)	
Add'l Weight for Copper Finned Coils, lbs (kg)	315 (143)		315 (143)		315 (143)		531 (241)		531 (241)	
Add'l Weight for Optional Louvers - Upper, lbs (kg)	167 (76)		167 (76)		167 (76)		167 (76)		167 (76)	
Add'l Weight for Optional Louvers - Lower, lbs (kg)	144 (65)		144 (65)		144 (65)		144 (65)		144 (65)	
Compressors										
Type	Tandem Scrolls		Tandem Scrolls		Tandem Scrolls		Tandem Scrolls		Tandem Scrolls	
Nominal tonnage of each Compressor	7.5	7.5	8.5	8.5	8.5	10	10	10	11.5	11.5
Number of Compressors per Circuit	2	2	2	2	2	2	2	2	2	2
Oil Charge per Compressor, oz (g)	85 (2410)	85 (2410)	110 (3119)	110 (3119)	110 (3119)	110 (3119)	110 (3119)	110 (3119)	110 (3119)	110 (3119)
Capacity Reduction Steps – Percent of Compressor Displacement										
Staging, 4 Stages, Circuit #1 in Lead	0-25-50-75-100		0-25-50-75-100		23-50-73-100		0-25-50-75-100		0-25-50-75-100	
Staging, 4 Stages, Circuit #2 in Lead	0-25-50-75-100		0-25-50-75-100		27-50-73-100		0-25-50-75-100		0-25-50-75-100	
Condensers – High Efficiency Fin and Tube Type with Integral Subcooling										
Coil Face Area, ft ² (m ²)	26.3 (2.4)	26.3 (2.4)	26.3 (2.4)	26.3 (2.4)	26.3 (2.4)	26.3 (2.4)	44.1 (4.1)	44.1 (4.1)	44.1 (4.1)	44.1 (4.1)
Finned HeightxFinned Length, in. (mm)	50x75.6 (1270x1920)	50x75.6 (1270x1920)	50x75.6 (1270x1920)	50x75.6 (1270x1920)	50x75.6 (1270x1920)	50x75.6 (1270x1920)	42x75.6 (1067x1920)	42x75.6 (1067x1920)	42x75.6 (1067x1920)	42x75.6 (1067x1920)
Fins per InchxRows Deep	16x3	16x3	16x3	16x3	16x3	16x3	16x2	16x2	16x3	16x3
Pumpdown Capacity, 90% Full, lbs (kg)	40 (18)	40 (18)	40 (18)	40 (18)	40 (18)	40 (18)	47 (21)	47 (21)	69 (31)	69 (31)
Condenser Fans – Direct Drive Propeller Type										
Number of Fans - Fan Diameter, in. (mm)	4 – 30 (762)		4 – 30 (762)		4 – 30 (762)		4 – 30 (762)		4 – 30 (762)	
Number of Motors - HP (kW) (Note 2)	4 – 1.5 (1.1)		4 – 1.5 (1.1)		4 – 1.5 (1.1)		4 – 1.5 (1.1)		4 – 1.5 (1.1)	
Fan and Motor RPM, 60Hz	1140		1140		1140		1140		1140	
60 Hz Fan Tip Speed, FPM (m/sec)	8950 (45)		8950 (45)		8950 (45)		8950 (45)		8950 (45)	
60 Hz Total Unit Airflow, CFM (l/sec)	24,316 (11,478)		24,316 (11,478)		24,316 (11,478)		39,600 (18,692)		37,228 (17,572)	
Evaporator – Brazed Plate-to-Plate										
Number of Evaporators	1		1		1		1		1	
Number of Refrigerant Circuits	2		2		2		2		2	
Water Volume, Gallons, (l)	2.01 (7.6)		2.01 (7.6)		2.22 (8.4)		2.43 (9.2)		2.85 (10.8)	
Maximum Water Pressure, psig (kPa)	653 (4502)		653 (4502)		653 (4502)		653 (4502)		653 (4502)	
Maximum Refrigerant Working Pressure, psig (kPa)	653 (4502)		653 (4502)		653 (4502)		653 (4502)		653 (4502)	
Water Inlet / Outlet Victaulic Connection, in. (mm)	2.5 (65)		2.5 (65)		2.5 (65)		2.5 (65)		2.5 (65)	
Drain - NPT int, in. (mm) (Note 4)	Field Piping		Field Piping		Field Piping		Field Piping		Field Piping	
Vent - NPT int, in. (mm) (Note 4)	Field Piping		Field Piping		Field Piping		Field Piping		Field Piping	

Nominal capacity based on 95°F ambient air temperature and 54°F/44°F water range
For all 380V/60 and 575V/60, hp = 2.0

Water connection shown is nominal pipe size

Brazed plate evaporators do not have drain or vent connections integral to the heat exchanger. The connections must be installed in the field. Inlet and outlet piping as shown in Piping Section of Catalog 611

Air-Cooled Chillers

AGZ 050D through AGZ 070D, Packaged

Data	AGZ050DH		AGZ055DH		AGZ060DH		AGZ065DH		AGZ070DH	
	Circuit 1	Circuit 2	Circuit 1	Circuit 2	Circuit 1	Circuit 2	Circuit 1	Circuit 2	Circuit 1	Circuit 2
Basic Data										
Unit Capacity @ AHRI Conditions (See Note 1), Tons (kW)	48 (169)		52 (181)		56 (197)		58 (204)		64 (225)	
Number of Refrigerant Circuits	2		2		2		2		2	
Unit Operating Charge, R-410A, lbs (kg)	50 (23)	50 (23)	52 (24)	52 (24)	54 (25)	54 (25)	58 (26)	58 (26)	60 (27)	60 (27)
Cabinet Dimensions, LxWxH, in. (mm)	94.4x88.0x100.4 (2398x2235x2550)		94.4x88.0x100.4 (2398x2235x2550)		94.4x88.0x100.4 (2398x2235x2550)		94.4x88.0x100.4 (2398x2235x2550)		94.4x88.0x100.4 (2398x2235x2550)	
Unit Operating Weight, lbs (kg)	3525 (1599)		3555 (1613)		3680 (1670)		3715 (1683)		4065 (1844)	
Unit Shipping Weight, lbs (kg)	3495 (1585)		3525 (1599)		3645 (1639)		3675 (1665)		4025 (1826)	
Add'l Weight for Copper Finned Coils, lbs (kg)	531 (241)		531 (241)		531 (241)		631 (286)		631 (286)	
Add'l Weight for Optional Louvers - Upper, lbs (kg)	167 (76)		167 (76)		167 (76)		167 (76)		167 (76)	
Add'l Weight for Optional Louvers - Lower, lbs (kg)	144 (65)		144 (65)		144 (65)		144 (65)		144 (65)	
Compressors										
Type	Tandem Scrolls		Tandem Scrolls		Tandem Scrolls		Tandem Scrolls		Tandem Scrolls	
Nominal tonnage of each Compressor	13	13	13	15	15	15	15	15	15/20	15/20
Number of Compressors per Circuit	2	2	2	2	2	2	2	2	2	2
Oil Charge per Compressor, oz (g)	110 (3119)	110 (3119)	110 (3119)	110 (3119)	110 (3119)	110 (3119)	110 (3119)	110 (3119)	110/135 (3119/3827)	110/135 (3119/3827)
Capacity Reduction Steps – Percent of Compressor Displacement										
Staging, 4 Stages, Circuit #1 in Lead	0-25-50-75-100		0-23-50-73-100		0-25-50-75-100		0-25-50-75-100		0-21-50-71-100	
Staging, 4 Stages, Circuit #2 in Lead	0-25-50-75-100		0-27-50-77-100		0-25-50-75-100		0-25-50-75-100		0-28-50-78-100	
Condensers – High Efficiency Fin and Tube Type with Integral Subcooling										
Coil Face Area, ft ² (m ²)	44.1 (4.1)	44.1 (4.1)	44.1 (4.1)	44.1 (4.1)	44.1 (4.1)	44.1 (4.1)	52.6 (4.9)	52.6 (4.9)	52.6 (4.9)	52.6 (4.9)
Finned HeightxFinned Length, in. (mm)	42x75.6 (1067x1920)	42x75.6 (1067x1920)	42x75.6 (1067x1920)	42x75.6 (1067x1920)	42x75.6 (1067x1920)	42x75.6 (1067x1920)	50x75.6 (1270x1920)	50x75.6 (1270x1920)	50x75.6 (1270x1920)	50x75.6 (1270x1920)
Fins per InchxRows Deep	16x3	16x3	16x3	16x3	16x3	16x3	16x3	16x3	16x3	16x3
Pumpdown Capacity, 90% Full, lbs (kg)	69 (31)	69 (31)	69 (31)	69 (31)	69 (31)	69 (31)	81 (37)	81 (37)	81 (37)	81 (37)
Condenser Fans – Direct Drive Propeller Type										
Number of Fans - Fan Diameter, in. (mm)	4 – 30 (762)		4 – 30 (762)		4 – 30 (762)		4 – 30 (762)		4 – 30 (762)	
Number of Motors - HP (kW) (Note 2)	4 – 1.5 (1.1)		4 – 1.5 (1.1)		4 – 1.5 (1.1)		4 – 2.0 (1.5)		4 – 2.0 (1.5)	
Fan and Motor RPM, 60Hz	1140		1140		1140		1140		1140	
60 Hz Fan Tip Speed, FPM (m/sec)	8950 (45)		8950 (45)		8950 (45)		8950 (45)		8950 (45)	
60 Hz Total Unit Airflow, CFM (l/sec)	37,228 (17,572)		37,228 (17,572)		37,228 (17,572)		43,452 (20,510)		43,452 (20,510)	
Evaporator – Brazed Plate-to-Plate										
Number of Evaporators	1		1		1		1		1	
Number of Refrigerant Circuits	2		2		2		2		2	
Water Volume, Gallons, (l)	3.28 (12.4)		3.49 (13.2)		4.04 (15.3)		4.76 (18.0)		4.76 (18.0)	
Maximum Water Pressure, psig (kPa)	653 (4502)		653 (4502)		653 (4502)		653 (4502)		653 (4502)	
Maximum Refrigerant Working Pressure, psig (kPa)	653 (4502)		653 (4502)		653 (4502)		653 (4502)		653 (4502)	
Water Inlet / Outlet Victaulic Connection, in. (mm)	2.5 (65)		2.5 (65)		3 (80)		3 (80)		3 (80)	
Drain - NPT int, in. (mm) (Note 4)	Field Piping		Field Piping		Field Piping		Field Piping		Field Piping	
Vent - NPT int, in. (mm) (Note 4)	Field Piping		Field Piping		Field Piping		Field Piping		Field Piping	

Nominal capacity based on 95°F ambient air temperature and 54°F/44°F water range
For all 380V/60 and 575V/60, hp = 2.0

Water connection shown is nominal pipe size

Brazed plate evaporators do not have drain or vent connections integral to the heat exchanger. The connections must be installed in the field. Inlet and outlet piping as shown in Piping Section of Catalog 611

Air-Cooled Chillers

AGZ 075D through AGZ 100D, Packaged

Data	AGZ075DH		AGZ080DH		AGZ090DH		AGZ100DH	
	Circuit 1	Circuit 2	Circuit 1	Circuit 2	Circuit 1	Circuit 2	Circuit 1	Circuit 2
Basic Data								
Unit Capacity @ AHRI Conditions (See Note 1), Tons (kW)	73 (257)		81 (285)		89 (314)		100 (351)	
Number of Refrigerant Circuits	2		2		2		2	
Unit Operating Charge, R-410A, lbs (kg)	75 (34)	75 (34)	80 (36)	80 (36)	86 (39)	86 (39)	88 (40)	88 (40)
Cabinet Dimensions, LxWxH, in. (mm)	134.9x88.0x100.4 (3426x2235x2550)		134.9x88.0x100.4 (3426x2235x2550)		134.9x88.0x100.4 (3426x2235x2550)		134.9x88.0x100.4 (3426x2235x2550)	
Unit Operating Weight, lbs (kg)	5350 (2427)		5385 (2443)		5420 (2459)		5675 (2574)	
Unit Shipping Weight, lbs (kg)	5305 (2406)		5335 (2420)		5365 (2434)		5610 (2545)	
Add'l Weight for Copper Finned Coils, lbs (kg)	801 (363)		801 (363)		950 (431)		950 (431)	
Add'l Weight for Optional Louvers - Upper, lbs (kg)	237 (108)		237 (108)		237 (108)		237 (108)	
Add'l Weight for Optional Louvers - Lower, lbs (kg)	187 (85)		187 (85)		187 (85)		187 (85)	
Compressors								
Type	Tandem Scrolls		Tandem Scrolls		Tandem Scrolls		Tandem Scrolls	
Nominal tonnage of each Compressor	20	20	20	25	25	25	25/30	25/30
Number of Compressors per Circuit	2	2	2	2	2	2	2	2
Oil Charge per Compressor, oz (g)	135 (3827)	135 (3827)	135 (3827)	145 (4111)	145 (4111)	145 (4111)	145/213 (4111/6038)	145/213 (4111/6038)
Capacity Reduction Steps – Percent of Compressor Displacement								
Staging, 4 Stages, Circuit #1 in Lead	0-25-50-75-100		0-22-50-72-100		0-25-50-75-100		0-22-50-72-100	
Staging, 4 Stages, Circuit #2 in Lead	0-25-50-75-100		0-28-50-78-100		0-25-50-75-100		0-22-50-72-100	
Condensers – High Efficiency Fin and Tube Type with Integral Subcooling								
Coil Face Area, ft ² (m ²)	66.2 (6.1)	66.2 (6.1)	66.2 (6.1)	66.2 (6.1)	78.8 (7.3)	78.8 (7.3)	78.8 (7.3)	78.8 (7.3)
Finned HeightxFinned Length, in. (mm)	42 x113.4 (1069x2880)	42 x113.4 (1069x2880)	42 x113.4 (1069x2880)	42 x113.4 (1069x2880)	50 x113.4 (1270x2880)	50 x113.4 (1270x2880)	50 x113.4 (1270x2880)	50 x113.4 (1270x2880)
Fins per InchxRows Deep	16x3	16x3	16x3	16x3	16x3	16x3	16x3	16x3
Pumpdown Capacity, 90% Full, lbs (kg)	111 (50)	111 (50)	111 (50)	111 (50)	130 (59)	130 (59)	130 (59)	130 (59)
Condenser Fans – Direct Drive Propeller Type								
Number of Fans - Fan Diameter, in. (mm)	6 – 30 (762)		6 – 30 (762)		6 – 30 (762)		6 – 30 (762)	
Number of Motors - HP (kW) (Note 2)	6 – 2.0 (1.5)		6 – 2.0 (1.5)		6 – 2.0 (1.5)		6 – 2.0 (1.5)	
Fan and Motor RPM, 60Hz	1140		1140		1140		1140	
60 Hz Fan Tip Speed, FPM (m/sec)	8950 (45)		8950 (45)		8950 (45)		8950 (45)	
60 Hz Total Unit Airflow, CFM (l/sec)	61,200 (28,888)		61,200 (28,888)		65,178 (30,765)		65,178 (30,765)	
Evaporator – Brazed Plate-to-Plate								
Number of Evaporators	1		1		1		1	
Number of Refrigerant Circuits	2		2		2		2	
Water Volume, Gallons, (l)	5.47 (20.7)		6.18 (23.4)		6.66 (25.2)		7.85 (29.7)	
Max. Water Pressure, psig (kPa)	653 (4502)		653 (4502)		653 (4502)		653 (4502)	
Maximum Refrigerant Working Pressure, psig (kPa)	653 (4502)		653 (4502)		653 (4502)		653 (4502)	
Water Inlet / Outlet Victaulic Connection, in. (mm)	3 (80)		3 (80)		3 (80)		3 (80)	
Drain - NPT int, in. (mm) (Note 3)	Field Piping		Field Piping		Field Piping		Field Piping	
Vent - NPT int, in. (mm) (Note 3)	Field Piping		Field Piping		Field Piping		Field Piping	

Nominal capacity based on 95°F ambient air temperature and 54°F/44°F water range
For all 380V/60 and 575V/60, hp = 2.0

Water connection shown is nominal pipe size

Brazed plate evaporators do not have drain or vent connections integral to the heat exchanger. The connections must be installed in the field. Inlet and outlet piping as shown in Piping Section of Catalog 611

Air-Cooled Chillers

AGZ 110D through AGZ 130D, Packaged, 208/230-Volt Models

Data	AGZ110DH		AGZ125DH		AGZ130DH	
	Circuit 1	Circuit 2	Circuit 1	Circuit 2	Circuit 1	Circuit 2
Basic Data						
Unit Capacity @ AHRI Conditions (See Note 1), Tons (kW)	106 (373)		117 (412)		130 (456)	
Number of Refrigerant Circuits	2		2		2	
Unit Operating Charge, R-410A, lbs (kg)	102 (46)	102 (46)	115 (52)	115 (52)	115 (52)	115 (52)
Cabinet Dimensions, LxWxH, in. (mm)	173.1x88.0x100.4 (4397x2235x2550)		173.1x88.0x100.4 (4397x2235x2550)		173.1x88.0x100.4 (4397x2235x2550)	
Unit Operating Weight, lbs (kg)	7120 (3230)		7265 (3295)		7320 (3320)	
Unit Shipping Weight, lbs (kg)	7050 (3198)		7185 (3259)		7230 (3280)	
Add'l Weight for Copper Finned Coils, lbs (kg)	1070 (486)		1269 (576)		1269 (576)	
Add'l Weight for Optional Louvers - Upper, lbs (kg)	307 (139)		307 (139)		307 (139)	
Add'l Weight for Optional Louvers - Lower, lbs (kg)	230 (105)		230 (105)		230 (105)	
Compressors						
Type	Trio Scrolls		Trio Scrolls		Trio Scrolls	
Nominal tonnage of each Compressor	20	20	20	25	25	25
Number of Compressors per Circuit	3	3	3	3	3	3
Oil Charge per Compressor, oz (g)	135 (3827)	135 (3827)	135 (3827)	145 (4111)	145 (4111)	145 (4111)
Capacity Reduction Steps – Percent of Compressor Displacement						
Staging, 6 Stages, Circuit #1 in Lead	0-17-33-50-67-83-100		0-15-33-48-67-81-100		0-17-33-50-67-83-100	
Staging, 6 Stages, Circuit #2 in Lead	0-17-33-50-67-83-100		0-19-33-52-67-86-100		0-17-33-50-67-83-100	
Condensers – High Efficiency Fin and Tube Type with Integral Subcooling						
Coil Face Area, ft ² (m ²)	88.4 (8.2)	88.4 (8.2)	105.3 (9.8)	105.3 (9.8)	105.3 (9.8)	105.3 (9.8)
Finned HeightxFinned Length, in. (mm)	42 x151.6 (1069x3851)	42 x151.6 (1069x3851)	50 x151.6 (1270x3851)	50 x151.6 (1270x3851)	50 x151.6 (1270x3851)	50 x151.6 (1270x3851)
Fins per InchxRows Deep	16x3	16x3	16x3	16x3	16x3	16x3
Pumpdown Capacity, 90% Full, lbs (kg)	142/64	142/64	166/75	166/75	166/75	166/75
Condenser Fans – Direct Drive Propeller Type						
Number of Fans - Fan Diameter, in. (mm)	8 – 30 (762)		8 – 30 (762)		8 – 30 (762)	
Number of Motors - HP (kW) (Note 2)	8 – 2.0 (1.5)		8 – 2.0 (1.5)		8 – 2.0 (1.5)	
Fan and Motor RPM, 60Hz	1140		1140		1140	
60 Hz Fan Tip Speed, FPM (m/sec)	8950 (45)		8950 (45)		8950 (45)	
60 Hz Total Unit Airflow, CFM (l/sec)	81,600 (38,517)		86,904 (41,020)		86,904 (41,020)	
Evaporator – Brazed Plate-to-Plate						
Number of Evaporators	1		1		1	
Number of Refrigerant Circuits	2		2		2	
Water Volume, Gallons, (l)	8.32 (31.5)		9.51 (36.0)		10.7 (40.5)	
Maximum Water Pressure, psig (kPa)	653 (4502)		653 (4502)		653 (4502)	
Maximum Refrigerant Working Pressure, psig (kPa)	653 (4502)		653 (4502)		653 (4502)	
Water Inlet / Outlet Victaulic Connection, in. (mm)	3 (80)		3 (80)		3 (80)	
Drain - NPT int, in. (mm) (Note 3)	Field Piping		Field Piping		Field Piping	
Vent - NPT int, in. (mm) (Note 3)	Field Piping		Field Piping		Field Piping	

Nominal capacity based on 95°F ambient air temperature and 54°F/44°F water range

For all 380V/60 and 575V/60, hp = 2.0

Water connection shown is nominal pipe size

Brazed plate evaporators do not have drain or vent connections integral to the heat exchanger. The connections must be installed in the field. Inlet and outlet piping as shown in Piping Section of Catalog 611

Air-Cooled Chillers

AGZ 110D through AGZ 130D, Packaged, 380/575-Volt Models

Data	AGZ110DH		AGZ125DH		AGZ130DH	
	Circuit 1	Circuit 2	Circuit 1	Circuit 2	Circuit 1	Circuit 2
Basic Data						
Unit Capacity @ AHRI Conditions (See Note 1), Tons (kW)	106 (373)		117 (412)		130 (456)	
Number of Refrigerant Circuits	2		2		2	
Unit Operating Charge, R-410A, lbs (kg)	102 (46)	102 (46)	115 (52)	115 (52)	115 (52)	115 (52)
Cabinet Dimensions, LxWxH, in. (mm)	173.1x88.0x100.4 (4397x2235x2550)		173.1x88.0x100.4 (4397x2235x2550)		173.1x88.0x100.4 (4397x2235x2550)	
Unit Operating Weight, lbs (kg)	7060(3202)		7205 (3268)		7260 (3293)	
Unit Shipping Weight, lbs (kg)	6990 (3170)		7125 (3232)		7170 (3252)	
Add'l Weight for Copper Finned Coils, lbs (kg)	1070 (486)		1269 (576)		1269 (576)	
Add'l Weight for Optional Louvers - Upper, lbs (kg)	307 (139)		307 (139)		307 (139)	
Add'l Weight for Optional Louvers - Lower, lbs (kg)	230 (105)		230 (105)		230 (105)	
Compressors						
Type	Trio Scrolls		Trio Scrolls		Trio Scrolls	
Nominal tonnage of each Compressor	20	20	20	25	25	25
Number of Compressors per Circuit	3	3	3	3	3	3
Oil Charge per Compressor, oz (g)	135 (3827)	135 (3827)	135 (3827)	145 (4111)	145 (4111)	145 (4111)
Capacity Reduction Steps – Percent of Compressor Displacement						
Staging, 6 Stages, Circuit #1 in Lead	0-17-33-50-67-83-100		0-15-33-48-67-81-100		0-17-33-50-67-83-100	
Staging, 6 Stages, Circuit #2 in Lead	0-17-33-50-67-83-100		0-19-33-52-67-86-100		0-17-33-50-67-83-100	
Condensers – High Efficiency Fin and Tube Type with Integral Subcooling						
Coil Face Area, ft ² (m ²)	88.4 (8.2)	88.4 (8.2)	105.3 (9.8)	105.3 (9.8)	105.3 (9.8)	105.3 (9.8)
Finned HeightxFinned Length, in. (mm)	42 x151.6 (1069x3851)	42 x151.6 (1069x3851)	50 x151.6 (1270x3851)	50 x151.6 (1270x3851)	50 x151.6 (1270x3851)	50 x151.6 (1270x3851)
Fins per InchxRows Deep	16x3	16x3	16x3	16x3	16x3	16x3
Pumpdown Capacity, 90% Full, lbs (kg)	142/64	142/64	166/75	166/75	166/75	166/75
Condenser Fans – Direct Drive Propeller Type						
Number of Fans - Fan Diameter, in. (mm)	8 – 30 (762)		8 – 30 (762)		8 – 30 (762)	
Number of Motors - HP (kW) (Note 2)	8 – 2.0 (1.5)		8 – 2.0 (1.5)		8 – 2.0 (1.5)	
Fan and Motor RPM, 60Hz	1140		1140		1140	
60 Hz Fan Tip Speed, FPM (m/sec)	8950 (45)		8950 (45)		8950 (45)	
60 Hz Total Unit Airflow, CFM (l/sec)	81,600 (38,517)		86,904 (41,020)		86,904 (41,020)	
Evaporator – Brazed Plate-to-Plate						
Number of Evaporators	1		1		1	
Number of Refrigerant Circuits	2		2		2	
Water Volume, Gallons, (l)	8.32 (31.5)		9.51 (36.0)		10.7 (40.5)	
Maximum Water Pressure, psig (kPa)	653 (4502)		653 (4502)		653 (4502)	
Maximum Refrigerant Working Pressure, psig (kPa)	653 (4502)		653 (4502)		653 (4502)	
Water Inlet / Outlet Victaulic Connection, in. (mm)	3 (80)		3 (80)		3 (80)	
Drain - NPT int, in. (mm) (Note 3)	Field Piping		Field Piping		Field Piping	
Vent - NPT int, in. (mm) (Note 3)	Field Piping		Field Piping		Field Piping	

Nominal capacity based on 95°F ambient air temperature and 54°F/44°F water range

For all 380V/60 and 575V/60, hp = 2.0

Water connection shown is nominal pipe size

Brazed plate evaporators do not have drain or vent connections integral to the heat exchanger. The connections must be installed in the field. Inlet and outlet piping as shown in Piping Section of Catalog 611

Air-Cooled Chillers

AGZ 140D through AGZ 190D, Packaged

Data	AGZ140DH		AGZ160DH		AGZ180DH		AGZ190DH	
	Circuit 1	Circuit 2	Circuit 1	Circuit 2	Circuit 1	Circuit 2	Circuit 1	Circuit 2
Basic Data								
Unit Capacity @ AHRI (See Note 1), Tons (kW)	136 (479)		153 (539)		172 (605)		180 (633)	
Number of Refrigerant Circuits	2		2		2		2	
Unit Operating Charge, R-410A, lbs (kg)	125 (57)	125 (57)	130 (59)	130 (59)	130 (59)	130 (59)	140 (64)	140 (64)
Cabinet Dimensions, LxWxH, in. (mm)	218.6 x 88.0 x 100.4 (5552 x 2235 x 2545)		218.6x88.0x100.4 (5552x2235x2545)		218.6x88.0x100.4 (5552x2235x2545)		256.9x88.0x100.4 (6525x2235x2545)	
Unit Operating Weight, lbs (kg)	9432(4278)		9762 (4428)		10107 (4578)		11070 (5015)	
Unit Shipping Weight, lbs (kg)	8950 (4060)		9280 (4209)		9625 (4360)		10585 (4795)	
Add'l Weight for Copper Finned Coils, lbs (kg)	1588 (720)		1588 (720)		1588 (720)		1908 (865)	
Add'l Weight for Optional Louvers - Upper, lbs (kg)	376 (171)		376 (171)		376 (171)		446 (202)	
Add'l Weight for Optional Louvers - Lower, lbs (kg)	225 (102)		225 (102)		225 (102)		323 (146)	
Compressors								
Type	Trio Scrolls		Trio Scrolls		Trio Scrolls		Trio Scrolls	
Nominal tonnage of each Compressor	25	25	25	30	30	30	30	30
Number of Compressors per Circuit	3	3	3	3	3	3	3	3
Oil Charge per Compressor, oz (g)	145 (4111)	145 (4111)	145 (4111)	213 (6038)	213 (6038)	213 (6038)	213 (6038)	213 (6038)
Capacity Reduction Steps – Percent of Compressor Displacement								
Staging, 6 Stages, Circuit #1 in Lead	0-17-33-50-67-83-100		0-15-33-48-67-81-100		0-17-33-50-67-83-100		0-17-33-50-67-83-100	
Staging, 6 Stages, Circuit #2 in Lead	0-17-33-50-67-83-100		0-19-33-52-67-86-100		0-17-33-50-67-83-100		0-17-33-50-67-83-100	
Condensers – High Efficiency Fin and Tube Type with Integral Subcooling								
Coil Face Area, ft ² (m ²)	131.8 (12.2)	131.8 (12.2)	131.8 (12.2)	131.8 (12.2)	131.8 (12.2)	131.8 (12.2)	158.3 (14.7)	158.3 (14.7)
Finned HeightxFinned Length, in. (mm)	50 x 190 (1270x4821)	50 x 190 (1270x4821)	50x190 (1270x4821)	50x190 (1270x4821)	50x190 (1270x4821)	50x190 (1270x4821)	50x228 (1270x5791)	50x228 (1270x5791)
Fins per InchxRows Deep	16 x 3	16 x 3	16x3	16x3	16x3	16x3	16x3	16x3
Pumpdown Capacity, 90% Full, lbs (kg)	202 (92)	202 (92)	202 (92)	202 (92)	202 (92)	202 (92)	242 (110)	242 (110)
Condenser Fans – Direct Drive Propeller Type								
Number of Fans - Fan Diameter, in. (mm)	10 – 30 (762)		10 – 30 (762)		10 – 30 (762)		12 – 30 (762)	
Number of Motors - HP (kW) (Note 2)	10 – 2.0 (1.5)		10 – 2.0 (1.5)		10 – 2.0 (1.5)		12 - 2.0 (1.5)	
Fan and Motor RPM, 60Hz	1140		1140		1140		1140	
60 Hz Fan Tip Speed, FPM (m/sec)	8950 (45)		8950 (45)		8950 (45)		8950 (45)	
60 Hz Total Unit Airflow, CFM (l/sec)	108,630 (51,268)		108,630 (51,268)		108,630 (51,268)		130,356 (61,522)	
Evaporator – Shell-and-Tube								
Number of Evaporators	1		1		1		1	
Number of Refrigerant Circuits	2		2		2		2	
Water Volume, Gallons, (l)	60 (227)		60 (227)		58 (219)		57 (215)	
Maximum Water Pressure, psig (kPa)	152 (1048)		152 (1048)		152 (1048)		152 (1048)	
Maximum Refrigerant Working Pressure, psig (kPa)	450 (3103)		450 (3103)		450 (3103)		450 (3103)	
Water Inlet / Outlet Victaulic Connection, in. (mm)	8.0 (200)		8.0 (200)		8.0 (200)		8.0 (200)	
Drain - NPT int, in.	½-in. NPTF		½-in. NPTF		½-in. NPTF		½-in. NPTF	
Vent - NPT int, in.	½-in. NPTF		½-in. NPTF		½-in. NPTF		½-in. NPTF	

Nominal capacity based on 95°F ambient air temperature and 54°F/44°F water range

For all 380V/60 and 575V/60, hp = 2.0

Water connection shown is nominal pipe size

Brazed plate evaporators do not have drain or vent connections integral to the heat exchanger. The connections must be installed in the field. Inlet and outlet piping as shown in Piping Section of Catalog 611

Air-Cooled Chillers

Physical Data—Remote Evaporator Units

AGZ 025D through AGZ 045D, Remote Evaporator

Data	AGZ025DB Remote Evap		AGZ030DB Remote Evap		AGZ035DB Remote Evap		AGZ040DB Remote Evap		AGZ045DB Remote Evap	
	Circuit 1	Circuit 2	Circuit 1	Circuit 2	Circuit 1	Circuit 2	Circuit 1	Circuit 2	Circuit 1	Circuit 2
Basic Data										
Unit Capacity @ AHRI Conditions (See Note 1), Tons (kW)	27 (96)		32 (111)		35 (123)		38 (133)		43 (150)	
Number of Refrigerant Circuits	2		2		2		2		2	
Unit Operating Charge, R-410A, lbs (kg)	28 (13)	28 (13)	32 (15)	32 (15)	32 (15)	32 (15)	39 (17)	39 (17)	44 (20)	44 (20)
Cabinet Dimensions, LxWxH, in. (mm)	94.4x88.0x100.4 (2398x2235x2550)		94.4x88.0x100.4 (2398x2235x2550)		94.4x88.0x100.4 (2398x2235x2550)		94.4x88.0x100.4 (2398x2235x2550)		94.4x88.0x100.4 (2398x2235x2550)	
Unit Operating Weight, lbs (kg)	3002 (1362)		3046 (1382)		3046 (1382)		3105 (1408)		3248 (1473)	
Unit Shipping Weight, lbs (kg)	2944 (1335)		2980 (1352)		2980 (1352)		3027 (1373)		3160 (1433)	
Add'l Weight for Copper Finned Coils, lbs (kg)	315 (143)		315 (143)		315 (143)		531 (241)		531 (241)	
Add'l Weight for Optional Louvers - Upper, lbs (kg)	167 (76)		167 (76)		167 (76)		167 (76)		167 (76)	
Add'l Weight for Optional Louvers - Lower, lbs (kg)	144 (65)		144 (65)		144 (65)		144 (65)		144 (65)	
Compressors										
Type	Tandem Scrolls		Tandem Scrolls		Tandem Scrolls		Tandem Scrolls		Tandem Scrolls	
Nominal tonnage of each Compressor	7.5	7.5	8.5	8.5	8.5	10	10	10	11.5	11.5
Number of Compressors per Circuit	2	2	2	2	2	2	2	2	2	2
Oil Charge per Compressor, oz (g)	85 (2410)	85 (2410)	110 (3119)	110 (3119)	110 (3119)	110 (3119)	110 (3119)	110 (3119)	110 (3119)	110 (3119)
Capacity Reduction Steps – Percent of Compressor Displacement										
Staging, 4 Stages, Circuit #1 in Lead	0-25-50-75-100		0-25-50-75-100		23-50-73-100		0-25-50-75-100		0-25-50-75-100	
Staging, 4 Stages, Circuit #2 in Lead	0-25-50-75-100		0-25-50-75-100		27-50-73-100		0-25-50-75-100		0-25-50-75-100	
Condensers – High Efficiency Fin and Tube Type with Integral Subcooling										
Coil Face Area, ft ² (m ²)	26.3 (2.4)	26.3 (2.4)	26.3 (2.4)	26.3 (2.4)	26.3 (2.4)	26.3 (2.4)	44.1 (4.1)	44.1 (4.1)	44.1 (4.1)	44.1 (4.1)
Finned HeightxFinned Length, in. (mm)	50x75.6 (1270x1920)	50x75.6 (1270x1920)	50x75.6 (1270x1920)	50x75.6 (1270x1920)	50x75.6 (1270x1920)	50x75.6 (1270x1920)	42x75.6 (1067x1920)	42x75.6 (1067x1920)	42x75.6 (1067x1920)	42x75.6 (1067x1920)
Fins per InchxRows Deep	16x3	16x3	16x3	16x3	16x3	16x3	16x2	16x2	16x3	16x3
Pumpdown Capacity, 90% Full, lbs (kg)	40 (18)	40 (18)	40 (18)	40 (18)	40 (18)	40 (18)	47 (21)	47 (21)	69 (31)	69 (31)
Condenser Fans – Direct Drive Propeller Type										
Number of Fans - Fan Diameter, in. (mm)	4 – 30 (762)		4 – 30 (762)		4 – 30 (762)		4 – 30 (762)		4 – 30 (762)	
Number of Motors - HP (kW) (Note 2)	4 – 1.5 (1.1)		4 – 1.5 (1.1)		4 – 1.5 (1.1)		4 – 1.5 (1.1)		4 – 1.5 (1.1)	
Fan and Motor RPM, 60Hz	1140		1140		1140		1140		1140	
60 Hz Fan Tip Speed, FPM (m/sec)	8950 (45)		8950 (45)		8950 (45)		8950 (45)		8950 (45)	
60 Hz Total Unit Airflow, CFM (l/sec)	24,316 (11,478)		24,316 (11,478)		24,316 (11,478)		39,600 (18,692)		37,228 (17,572)	
Remote Evaporator – Brazed Plate-to-Plate										
Number of Evaporators	1		1		1		1		1	
Number of Refrigerant Circuits	2		2		2		2		2	
Evaporator Model	ACH-230DQ-78H		ACH-230DQ-78H		ACH-230DQ-86H		ACH-230DQ-94H		ACH-230DQ-110H	
Dry Weight lbs (kg)	84 (38.1)		84 (38.1)		91 (41.3)		98 (44.5)		112 (50.1)	
Water Volume, Gallons, (l)	1.6 (6.1)		1.6 (6.1)		1.8 (6.8)		1.9 (7.2)		2.3 (8.7)	
Maximum Water Pressure, psig (kPa)	653 (4502)		653 (4502)		653 (4502)		653 (4502)		653 (4502)	
Maximum Refrigerant Working Pressure, psig (kPa)	653 (4502)		653 (4502)		653 (4502)		653 (4502)		653 (4502)	
Water Inlet / Outlet Victaulic Connection, in. (mm)	2.5 (65)		2.5 (65)		2.5 (65)		2.5 (65)		2.5 (65)	
Drain - NPT int, in. (mm) (Note 4)	Field Piping		Field Piping		Field Piping		Field Piping		Field Piping	
Vent - NPT int, in. (mm) (Note 4)	Field Piping		Field Piping		Field Piping		Field Piping		Field Piping	

Nominal capacity based on 95°F ambient air temperature and 54°F/44°F water range

For all 380V/60 and 575V/60, hp = 2.0

Water connection shown is nominal pipe size

Brazed plate evaporators do not have drain or vent connections integral to the heat exchanger. The connections must be installed in the field. Inlet and outlet piping as shown in Piping Section of Catalog 611

Air-Cooled Chillers

AGZ 050D through AGZ 070D, Remote Evaporator

Data	AGZ050DB Remote Evap		AGZ055DB Remote Evap		AGZ060DB Remote Evap		AGZ065DB Remote Evap		AGZ070DB Remote Evap	
	Circuit 1	Circuit 2	Circuit 1	Circuit 2	Circuit 1	Circuit 2	Circuit 1	Circuit 2	Circuit 1	Circuit 2
Basic Data										
Unit Capacity @ AHRI Conditions (See Note 1), Tons (kW)	48 (169)		52 (181)		56 (197)		58 (204)		64 (225)	
Number of Refrigerant Circuits	2		2		2		2		2	
Unit Operating Charge, R-410A, lbs (kg)	50 (23)	50(23)	52 (24)	52 (24)	54 (25)	54 (25)	58 (26)	58 (26)	60 (27)	60 (27)
Cabinet Dimensions, LxWxH, in. (mm)	94.4x88.0x100.4 (2398x2235x2550)		94.4x88.0x100.4 (2398x2235x2550)		94.4x88.0x100.4 (2398x2235x2550)		94.4x88.0x100.4 (2398x2235x2550)		94.4x88.0x100.4 (2398x2235x2550)	
Unit Operating Weight, lbs (kg)	3309 (1501)		3332 (1511)		3411 (1547)		3419 (1551)		3759 (1705)	
Unit Shipping Weight, lbs (kg)	3209 (1456)		3228 (1464)		3303 (1498)		3303 (1498)		3639 (1651)	
Add'l Weight for Copper Finned Coils, lbs (kg)	531 (241)		531 (241)		531 (241)		631 (286)		631 (286)	
Add'l Weight for Optional Louvers - Upper, lbs (kg)	167 (76)		167 (76)		167 (76)		167 (76)		167 (76)	
Add'l Weight for Optional Louvers - Lower, lbs (kg)	144 (65)		144 (65)		144 (65)		144 (65)		144 (65)	
Compressors										
Type	Tandem Scrolls		Tandem Scrolls		Tandem Scrolls		Tandem Scrolls		Tandem Scrolls	
Nominal tonnage of each Compressor	13	13	13	15	15	15	15	15	15/20	15/20
Number of Compressors per Circuit	2	2	2	2	2	2	2	2	2	2
Oil Charge per Compressor, oz (g)	110 (3119)	110 (3119)	110 (3119)	110 (3119)	110 (3119)	110 (3119)	110 (3119)	110 (3119)	110/135 (3119/3827)	110/135 (3119/3827)
Capacity Reduction Steps – Percent of Compressor Displacement										
Staging, 4 Stages, Circuit #1 in Lead	0-25-50-75-100		0-23-50-73-100		0-25-50-75-100		0-25-50-75-100		0-21-50-71-100	
Staging, 4 Stages, Circuit #2 in Lead	0-25-50-75-100		0-27-50-77-100		0-25-50-75-100		0-25-50-75-100		0-28-50-78-100	
Condensers – High Efficiency Fin and Tube Type with Integral Subcooling										
Coil Face Area, ft ² (m ²)	44.1 (4.1)	44.1 (4.1)	44.1 (4.1)	44.1 (4.1)	44.1 (4.1)	44.1 (4.1)	52.6 (4.9)	52.6 (4.9)	52.6 (4.9)	52.6 (4.9)
Finned HeightxFinned Length, in. (mm)	42x75.6 (1067x1920)	42x75.6 (1067x1920)	42x75.6 (1067x1920)	42x75.6 (1067x1920)	42x75.6 (1067x1920)	42x75.6 (1067x1920)	50x75.6 (1270x1920)	50x75.6 (1270x1920)	50x75.6 (1270x1920)	50x75.6 (1270x1920)
Fins per InchxRows Deep	16x3	16x3	16x3	16x3	16x3	16x3	16x3	16x3	16x3	16x3
Pumpdown Capacity, 90% Full, lbs (kg)	69 (31)	69 (31)	69 (31)	69 (31)	69 (31)	69 (31)	81 (37)	81 (37)	81 (37)	81 (37)
Condenser Fans – Direct Drive Propeller Type										
Number Of Fans - Fan Diameter, in. (mm)	4 – 30 (762)		4 – 30 (762)		4 – 30 (762)		4 – 30 (762)		4 – 30 (762)	
Number of Motors - HP (kW) (Note 2)	4 – 1.5 (1.1)		4 – 1.5 (1.1)		4 – 1.5 (1.1)		4 – 2.0 (1.5)		4 – 2.0 (1.5)	
Fan and Motor RPM, 60Hz	1140		1140		1140		1140		1140	
60 Hz Fan Tip Speed, FPM (m/sec)	8950 (45)		8950 (45)		8950 (45)		8950 (45)		8950 (45)	
60 Hz Total Unit Airflow, CFM (l/sec)	37,228 (17,572)		37,228 (17,572)		37,228 (17,572)		43,452 (20,510)		43,452 (20,510)	
Remote Evaporator – Brazed Plate-to-Plate										
Number of Evaporators	1		1		1		1		1	
Number of Refrigerant Circuits	2		2		2		2		2	
Evaporator Model	ACH-230DQ-126H		ACH-230DQ-134H		ACH-500DQ-70H		ACH-500DQ-82H		ACH-500DQ-82H	
Dry Weight lbs (kg)	126 (57.2)		133 (60.3)		158 (71.7)		180 (81.7)		180 (81.7)	
Water Volume, Gallons, (l)	2.6 (9.8)		2.8 (10.6)		4.2 (15.9)		4.9 (18.6)		4.9 (18.6)	
Maximum Water Pressure, psig (kPa)	653 (4502)		653 (4502)		653 (4502)		653 (4502)		653 (4502)	
Maximum Refrigerant Working Pressure, psig (kPa)	653 (4502)		653 (4502)		653 (4502)		653 (4502)		653 (4502)	
Water Inlet / Outlet Victaulic Connection, in. (mm)	2.5 (65)		2.5 (65)		3 (80)		3 (80)		3 (80)	
Drain - NPT int, in. (mm) (Note 4)	Field Piping		Field Piping		Field Piping		Field Piping		Field Piping	
Vent - NPT int, in. (mm) (Note 4)	Field Piping		Field Piping		Field Piping		Field Piping		Field Piping	

Nominal capacity based on 95°F ambient air temperature and 54°F/44°F water range
For all 380V/60 and 575V/60, hp = 2.0
Water connection shown is nominal pipe size

Brazed plate evaporators do not have drain or vent connections integral to the heat exchanger. The connections must be installed in the field. Inlet and outlet piping as shown in Piping Section of Catalog 611

Air-Cooled Chillers

AGZ 075D through AGZ 100D, Remote Evaporator

Data	AGZ075DB Remote Evap		AGZ080DB Remote Evap		AGZ090DB Remote Evap		AGZ100DB Remote Evap	
	Circuit 1	Circuit 2	Circuit 1	Circuit 2	Circuit 1	Circuit 2	Circuit 1	Circuit 2
Basic Data								
Unit Capacity @ AHRI Conditions (See Note 1), Tons (kW)	73 (257)		81 (285)		89 (314)		100 (351)	
Number Of Refrigerant Circuits	2		2		2		2	
Unit Operating Charge, R-410A, lbs (kg)	75 (34)	75 (34)	80 (36)	80 (36)	86 (39)	86 (39)	88 (40)	88 (40)
Cabinet Dimensions, LxWxH, in. (mm)	134.9x88.0x100.4 (3426x2235x2550)		134.9x88.0x100.4 (3426x2235x2550)		134.9x88.0x100.4 (3426x2235x2550)		134.9x88.0x100.4 (3426x2235x2550)	
Unit Operating Weight, lbs (kg)	4997(2267)		5004 (2270)		5020 (2277)		5228 (2371)	
Unit Shipping Weight, lbs (kg)	4847 (2199)		4844 (2197)		4848 (2199)		5052 (2292)	
Add'l Weight for Copper Finned Coils, lbs (kg)	801 (363)		801 (363)		950 (431)		950 (431)	
Add'l Weight for Optional Louvers - Upper, lbs (kg)	237 (108)		237 (108)		237 (108)		237 (108)	
Add'l Weight for Optional Louvers - Lower, lbs (kg)	187 (85)		187 (85)		187 (85)		187 (85)	
Compressors								
Type	Tandem Scrolls		Tandem Scrolls		Tandem Scrolls		Tandem Scrolls	
Nominal tonnage of each Compressor	20	20	20	25	25	25	25/30	25/30
Number of Compressors per Circuit	2	2	2	2	2	2	2	2
Oil Charge per Compressor, oz (g)	135 (3827)	135 (3827)	135 (3827)	145 (4111)	145 (4111)	145 (4111)	145/213 4111/6038	145/213 4111/6038
Capacity Reduction Steps – Percent of Compressor Displacement								
Staging, 4 Stages, Circuit #1 in Lead	0-25-50-75-100		0-22-50-72-100		0-25-50-75-100		0-22-50-72-100	
Staging, 4 Stages, Circuit #2 in Lead	0-25-50-75-100		0-28-50-78-100		0-25-50-75-100		0-22-50-72-100	
Condensers – High Efficiency Fin and Tube Type with Integral Subcooling								
Coil Face Area, ft ² (m ²)	66.2 (6.1)	66.2 (6.1)	66.2 (6.1)	66.2 (6.1)	78.8 (7.3)	78.8 (7.3)	78.8 (7.3)	78.8 (7.3)
Finned HeightxFinned Length, in. (mm)	42 x113.4 (1069x2880)	42 x113.4 (1069x2880)	42 x113.4 (1069x2880)	42 x113.4 (1069x2880)	50 x113.4 (1270x2880)	50 x113.4 (1270x2880)	50 x113.4 (1270x2880)	50 x113.4 (1270x2880)
Fins per InchxRows Deep	16x3	16x3	16x3	16x3	16x3	16x3	16x3	16x3
Pumpdown Capacity, 90% Full, lbs (kg)	111 (50)	111 (50)	111 (50)	111 (50)	130 (59)	130 (59)	130 (59)	130 (59)
Condenser Fans – Direct Drive Propeller Type								
Number of Fans - Fan Diameter, in. (mm)	6 – 30 (762)		6 – 30 (762)		6 – 30 (762)		6 – 30 (762)	
Number of Motors - HP (kW)	6 – 2.0 (1.5)		6 – 2.0 (1.5)		6 – 2.0 (1.5)		6 – 2.0 (1.5)	
Fan and Motor RPM, 60Hz	1140		1140		1140		1140	
60 Hz Fan Tip Speed, FPM (m/sec)	8950 (45)		8950 (45)		8950 (45)		8950 (45)	
60 Hz Total Unit Airflow, CFM (l/sec)	61,200 (28,888)		61,200 (28,888)		65,178 (30,765)		65,178 (30,765)	
Remote Evaporator – Brazed Plate-to-Plate								
Number of Evaporators	1		1		1		1	
Number of Refrigerant Circuits	2		2		2		2	
Evaporator Model	ACH-500DQ-94H		ACH-500DQ-106H		ACH-500DQ-114H		ACH-500DQ-134H	
Dry Weight lbs (kg)	207 (93.9)		230 (104.3)		244 (110.7)		281 (127.5)	
Water Volume, Gallons, (l)	5.6 (21.2)		6.3 (23.9)		6.8 (25.7)		7.9 (29.9)	
Maximum Water Pressure, psig (kPa)	653 (4502)		653 (4502)		653 (4502)		653 (4502)	
Maximum Refrigerant Working Pressure, psig (kPa)	653 (4502)		653 (4502)		653 (4502)		653 (4502)	
Water Inlet / Outlet Victaulic Connection, in. (mm)	3 (80)		3 (80)		3 (80)		3 (80)	
Drain - NPT int, in. (mm) (Note 3)	Field Piping		Field Piping		Field Piping		Field Piping	
Vent - NPT int, in. (mm) (Note 3)	Field Piping		Field Piping		Field Piping		Field Piping	

Nominal capacity based on 95°F ambient air temperature and 54°F/44°F water range

For all 380V/60 and 575V/60, hp = 2.0

Water connection shown is nominal pipe size

Brazed plate evaporators do not have drain or vent connections integral to the heat exchanger. The connections must be installed in the field. Inlet and outlet piping as shown in Piping Section of Catalog 611

Air-Cooled Chillers

AGZ 110D through AGZ 130D, Remote Evaporator, 208/230-Volt Models

Data	AGZ110DB Remote Evap		AGZ125DB Remote Evap		AGZ130DB Remote Evap	
	Circuit 1	Circuit 2	Circuit 1	Circuit 2	Circuit 1	Circuit 2
Basic Data						
Unit Capacity @ AHRI Conditions (See Note 1), Tons (kW)	106 (373)		117 (412)		130 (456)	
Number of Refrigerant Circuits	2		2		2	
Unit Operating Charge, R-410A, lbs (kg)	102 (46)	102 (46)	115 (52)	115 (52)	115 (52)	115 (52)
Cabinet Dimensions, LxWxH, in. (mm)	173.1x88.0x100.4 (4397x2235x2550)		173.1x88.0x100.4 (4397x2235x2550)		173.1x88.0x100.4 (4397x2235x2550)	
Unit Operating Weight, lbs (kg)	6748 (3061)		6846 (3105)		6854 (3109)	
Unit Shipping Weight, lbs (kg)	6544 (2968)		6616 (3001)		6624 (3005)	
Add'l Weight for Copper Finned Coils, lbs (kg)	1070 (486)		1269 (576)		1269 (576)	
Add'l Weight for Optional Louvers - Upper, lbs (kg)	307 (139)		307 (139)		307 (139)	
Add'l Weight for Optional Louvers - Lower, lbs (kg)	230 (105)		230 (105)		230 (105)	
Compressors						
Type	Trio Scrolls		Trio Scrolls		Trio Scrolls	
Nominal tonnage of each Compressor	20	20	20	25	25	25
Number of Compressors per Circuit	3	3	3	3	3	3
Oil Charge per Compressor, oz (g)	135 (3827)	135 (3827)	135 (3827)	145 (4111)	145 (4111)	145 (4111)
Capacity Reduction Steps – Percent of Compressor Displacement						
Staging, 6 Stages, Circuit #1 in Lead	0-17-33-50-67-83-100		0-15-33-48-67-81-100		0-17-33-50-67-83-100	
Staging, 6 Stages, Circuit #2 in Lead	0-17-33-50-67-83-100		0-19-33-52-67-86-100		0-17-33-50-67-83-100	
Condensers – High Efficiency Fin and Tube Type with Integral Subcooling						
Coil Face Area, ft ² (m ²)	88.4 (8.2)	88.4 (8.2)	105.3 (9.8)	105.3 (9.8)	105.3 (9.8)	105.3 (9.8)
Finned HeightxFinned Length, in. (mm)	42 x151.6 (1069x3851)	42 x151.6 (1069x3851)	50 x151.6 (1270x3851)	50 x151.6 (1270x3851)	50 x151.6 (1270x3851)	50 x151.6 (1270x3851)
Fins per InchxRows Deep	16x3	16x3	16x3	16x3	16x3	16x3
Pumpdown Capacity, 90% Full, lbs (kg)	142/64	142/64	166/75	166/75	166/75	166/75
Condenser Fans – Direct Drive Propeller Type						
Number of Fans - Fan Diameter, in. (mm)	8 – 30 (762)		8 – 30 (762)		8 – 30 (762)	
Number of Motors - HP (kW)	8 – 2.0 (1.5)		8 – 2.0 (1.5)		8 – 2.0 (1.5)	
Fan and Motor RPM, 60Hz	1140		1140		1140	
60 Hz Fan Tip Speed, FPM (m/sec)	8950 (45)		8950 (45)		8950 (45)	
60 Hz Total Unit Airflow, CFM (l/sec)	81,600 (38,517)		86,904 (41,020)		86,904 (41,020)	
Remote Evaporator – Brazed Plate-to-Plate						
Number of Evaporators	1		1		1	
Number of Refrigerant Circuits	2		2		2	
Evaporator Model	ACH-500DQ-142H		ACH-500DQ-162H		ACH-500DQ-182H	
Dry Weight lbs (kg)	296 (134.3)		333 (151.1)		370 (167.8)	
Water Volume, Gallons, (l)	8.4 (31.8)		9.6 (36.3)		10.8 (40.9)	
Maximum Water Pressure, psig (kPa)	653 (4502)		653 (4502)		653 (4502)	
Maximum Refrigerant Working Pressure, psig (kPa)	653 (4502)		653 (4502)		653 (4502)	
Water Inlet / Outlet Victaulic Connection, in. (mm)	3 (80)		3 (80)		3 (80)	
Drain - NPT int, in. (mm) (Note 3)	Field Piping		Field Piping		Field Piping	
Vent - NPT int, in. (mm) (Note 3)	Field Piping		Field Piping		Field Piping	

NOTE: This table for 208/230V models only. Information for 380V, 460V, and 575V models next page.

Nominal capacity based on 95°F ambient air temperature and 54°F/44°F water range

For all 380V/60 and 575V/60, hp = 2.0

Water connection shown is nominal pipe size

Brazed plate evaporators do not have drain or vent connections integral to the heat exchanger. The connections must be installed in the field. Inlet and outlet piping as shown in Piping Section of Catalog 611

Air-Cooled Chillers

AGZ 110D through AGZ 130D, Remote Evaporator, 380/575-Volt Models

Data	AGZ110DB Remote Evap		AGZ125DB Remote Evap		AGZ130DB Remote Evap	
	Circuit 1	Circuit 2	Circuit 1	Circuit 2	Circuit 1	Circuit 2
Basic Data						
Unit Capacity @ AHRI Conditions (See Note 1), Tons (kW)	106 (373)		117 (412)		130 (456)	
Number of Refrigerant Circuits	2		2		2	
Unit Operating Charge, R-410A, lbs (kg)	102 (46)	102 (46)	115 (52)	115 (52)	115 (52)	115 (52)
Cabinet Dimensions, LxWxH, in. (mm)	173.1x88.0x100.4 (4397x2235x2550)		173.1x88.0x100.4 (4397x2235x2550)		173.1x88.0x100.4 (4397x2235x2550)	
Unit Operating Weight, lbs (kg)	6633 (3009)		6731 (3053)		6739 (3057)	
Unit Shipping Weight, lbs (kg)	6429 (2916)		6501 (2949)		6379 (2894)	
Add'l Weight for Copper Finned Coils, lbs (kg)	1070 (486)		1269 (576)		1269 (576)	
Add'l Weight for Optional Louvers - Upper, lbs (kg)	307 (139)		307 (139)		307 (139)	
Add'l Weight for Optional Louvers - Lower, lbs (kg)	230 (105)		230 (105)		230 (105)	
Compressors						
Type	Trio Scrolls		Trio Scrolls		Trio Scrolls	
Nominal tonnage of each Compressor	20	20	20	25	25	25
Number of Compressors per Circuit	3	3	3	3	3	3
Oil Charge per Compressor, oz (g)	135 (3827)	135 (3827)	135 (3827)	145 (4111)	145 (4111)	145 (4111)
Capacity Reduction Steps – Percent of Compressor Displacement						
Staging, 6 Stages, Circuit #1 in Lead	0-17-33-50-67-83-100		0-15-33-48-67-81-100		0-17-33-50-67-83-100	
Staging, 6 Stages, Circuit #2 in Lead	0-17-33-50-67-83-100		0-19-33-52-67-86-100		0-17-33-50-67-83-100	
Condensers – High Efficiency Fin and Tube Type with Integral Subcooling						
Coil Face Area, ft ² (m ²)	88.4 (8.2)	88.4 (8.2)	105.3 (9.8)	105.3 (9.8)	105.3 (9.8)	105.3 (9.8)
Finned HeightxFinned Length, in. (mm)	42 x151.6 (1069x3851)	42 x151.6 (1069x3851)	50 x151.6 (1270x3851)	50 x151.6 (1270x3851)	50 x151.6 (1270x3851)	50 x151.6 (1270x3851)
Fins per InchxRows Deep	16x3	16x3	16x3	16x3	16x3	16x3
Pumpdown Capacity, 90% Full, lbs (kg)	142/64	142/64	166/75	166/75	166/75	166/75
Condenser Fans – Direct Drive Propeller Type						
Number of Fans - Fan Diameter, in. (mm)	8 – 30 (762)		8 – 30 (762)		8 – 30 (762)	
Number of Motors - HP (kW)	8 – 2.0 (1.5)		8 – 2.0 (1.5)		8 – 2.0 (1.5)	
Fan and Motor RPM, 60Hz	1140		1140		1140	
60 Hz Fan Tip Speed, FPM (m/sec)	8950 (45)		8950 (45)		8950 (45)	
60 Hz Total Unit Airflow, CFM (l/sec)	81,600 (38,517)		86,904 (41,020)		86,904 (41,020)	
Remote Evaporator – Brazed Plate-to-Plate						
Number of Evaporators	1		1		1	
Number of Refrigerant Circuits	2		2		2	
Evaporator Model	ACH-500DQ-142H		ACH-500DQ-162H		ACH-500DQ-182H	
Dry Weight lbs (kg)	296 (134.3)		333 (151.1)		370 (167.8)	
Water Volume, Gallons, (l)	8.4 (31.8)		9.6 (36.3)		10.8 (40.9)	
Maximum Water Pressure, psig (kPa)	653 (4502)		653 (4502)		653 (4502)	
Maximum Refrigerant Working Pressure, psig (kPa)	653 (4502)		653 (4502)		653 (4502)	
Water Inlet / Outlet Victaulic Connection, in. (mm)	3 (80)		3 (80)		3 (80)	
Drain - NPT int, in. (mm) (Note 3)	Field Piping		Field Piping		Field Piping	
Vent - NPT int, in. (mm) (Note 3)	Field Piping		Field Piping		Field Piping	

NOTE: This table for 380V, 460V, and 575V models only. Information for 208/230V models previous page.

Nominal capacity based on 95°F ambient air temperature and 54°F/44°F water range

For all 380V/60 and 575V/60, hp = 2.0

Water connection shown is nominal pipe size

Brazed plate evaporators do not have drain or vent connections integral to the heat exchanger. The connections must be installed in the field. Inlet and outlet piping as shown in Piping Section of Catalog 611

Air-Cooled Chillers

AGZ 140D through AGZ 190D, Remote Evaporator

Data	AGZ140DB Remote Evap		AGZ160DB Remote Evap		AGZ180DB Remote Evap		AGZ190DB Remote Evap	
	Circuit 1	Circuit 2	Circuit 1	Circuit 2	Circuit 1	Circuit 2	Circuit 1	Circuit 2
Basic Data								
Unit Capacity @ AHR1 (See Note 1), Tons (kW)	136 (479)		153 (539)		172 (605)		180 (633)	
Number of Refrigerant Circuits	2		2		2		2	
Unit Operating Charge, R-410A, lbs (kg)	125 (57)	125 (57)	130 (59)	130 (59)	130 (59)	130 (59)	140 (64)	140 (64)
Cabinet Dimensions, LxWxH, in. (mm)	218.6x88.0x100.4 (5552x2235x2545)		218.6x88.0x100.4 (5552x2235x2545)		218.6x88.0x100.4 (5552x2235x2545)		256.9x88.0x100.4 (6525x2235x2545)	
Unit Operating Weight, lbs (kg)	7990 (3624)		8320 (3774)		8635 (3917)		9555 (4334)	
Unit Shipping Weight, lbs (kg)	7740 (3511)		8060 (3656)		8375 (3799)		9255 (4198)	
Add'l Weight for Copper Finned Coils, lbs (kg)	1588 (720)		1588 (720)		1588 (720)		1908 (865)	
Add'l Weight for Optional Louvers - Upper, lbs (kg)	376 (171)		376 (171)		376 (171)		446 (202)	
Add'l Weight for Optional Louvers - Lower, lbs (kg)	225 (102)		225 (102)		225 (102)		323 (146)	
Compressors								
Type	Trio Scrolls		Trio Scrolls		Trio Scrolls		Trio Scrolls	
Nominal tonnage of each Compressor	25	25	25	30	30	30	30	30
Number of Compressors per Circuit	3	3	3	3	3	3	3	3
Oil Charge per Compressor, oz (g)	145 (4111)	145 (4111)	145 (4111)	213 (6038)	213 (6038)	213 (6038)	213 (6038)	213 (6038)
Capacity Reduction Steps – Percent of Compressor Displacement								
Staging, 6 Stages, Circuit #1 in Lead	0-17-33-50-67-83-100		0-15-33-48-67-81-100		0-17-33-50-67-83-100		0-17-33-50-67-83-100	
Staging, 6 Stages, Circuit #2 in Lead	0-17-33-50-67-83-100		0-19-33-52-67-86-100		0-17-33-50-67-83-100		0-17-33-50-67-83-100	
Condensers – High Efficiency Fin and Tube Type with Integral Subcooling								
Coil Face Area, ft ² (m ²)	131.8 (12.2)	131.8 (12.2)	131.8 (12.2)	131.8 (12.2)	131.8 (12.2)	131.8 (12.2)	158.3 (14.7)	158.3 (14.7)
Finned HeightxFinned Length, in. (mm)	50x190 (1270x4821)	50x190 (1270x4821)	50x190 (1270x4821)	50x190 (1270x4821)	50x190 (1270x4821)	50x190 (1270x4821)	50x228 (1270x5791)	50x228 (1270x5791)
Fins per InchxRows Deep	16x3	16x3	16x3	16x3	16x3	16x3	16x3	16x3
Pumpdown Capacity, 90% Full, lbs (kg)	202 (92)	202 (92)	202 (92)	202 (92)	202 (92)	202 (92)	242 (110)	242 (110)
Condenser Fans – Direct Drive Propeller Type								
Number of Fans - Fan Diameter, in. (mm)	10 – 30 (762)		10 – 30 (762)		10 – 30 (762)		12 – 30 (762)	
Number of Motors - HP (kW)	10 – 2.0 (1.5)		10 – 2.0 (1.5)		10 – 2.0 (1.5)		12 - 2.0 (1.5)	
Fan and Motor RPM, 60Hz	1140		1140		1140		1140	
60 Hz Fan Tip Speed, FPM (m/sec)	8950 (45)		8950 (45)		8950 (45)		8950 (45)	
60 Hz Total Unit Airflow, CFM (l/sec)	108,630 (51,268)		108,630 (51,268)		108,630 (51,268)		130,356 (61,522)	
Remote Evaporator – Shell-and-Tube								
Number of Evaporators	1		1		1		1	
Number of Refrigerant Circuits	2		2		2		2	
Evaporator Model	EV34191010/9		EV34191111/9		EV34191111/9		EV34191212/7	
Dry Weight lbs (kg)	840 (381)		840 (381)		870 (395)		900 (408)	
Water Volume, Gallons, (l)	58.8 (223)		57.8 (219)		57.8 (219)		56.8 (215)	
Maximum Water Pressure, psig (kPa)	152 (1048)		152 (1048)		152 (1048)		152 (1048)	
Maximum Refrig. Working Pressure, psig (kPa)	450 (3103)		450 (3103)		450 (3103)		450 (3103)	
Water Inlet / Outlet Victaulic Connection, in. (mm)	8.0 (200)		8.0 (200)		8.0 (200)		8.0 (200)	
Drain - NPT int, in.	½-in. NPTF		½-in. NPTF		½-in. NPTF		½-in. NPTF	
Vent - NPT int, in.	½-in. NPTF		½-in. NPTF		½-in. NPTF		½-in. NPTF	

Nominal capacity based on 95°F ambient air temperature and 54°F/44°F water range

For all 380V/60 and 575V/60, hp = 2.0

Water connection shown is nominal pipe size

Brazed plate evaporators do not have drain or vent connections integral to the heat exchanger. The connections must be installed in the field. Inlet and outlet piping as shown in Piping Section of

Catalog 611

Air-Cooled Chillers

Pathfinder® Air-Cooled Screw Compressor Chillers—170 to 550 Tons

- Three levels of efficiency: *Standard, High* and *Premium*
- Integrated VFD further enhances part load IPLV to industry-leading efficiency
- Quietest air-cooled screw chiller with sound pressure levels published, as low as 66 dBA with no attenuation
- Contributes to LEED® Green Building Rating System™ points for enhanced refrigerant management and optimized energy efficiency
- Small unit footprint makes it ideal for retrofit and replacement projects
- Available with remote evaporator for keeping all chilled water piping within a building
- Power factor correction capacitors - a factory installed option - achieve a full load power factor of 0.95 for potentially lower utility bills due to the reduction of utility penalties for low power factor systems
- RapidRestore™ option with Fast Loading allows a Pathfinder Chiller to provide up to 100% cooling in less than five minutes
- D-Net® Performance Services compatible for proactive support, faster service response, and quicker issue resolution (Model AWS)

For more detail, refer to Catalog 600.

For the most current information, refer to DaikinApplied.com.



Pathfinder Chiller - 170 to 550 tons,
Model AWS, R-134a
(shown with optional VFD)



Air Cooled Screw Compressor Chiller,
Model AGS-D 140 to 200 tons
Packaged Chiller or with Remote Evaporator



Air-Cooled Chillers



Which Pathfinder Chiller is right for your system?

	Standard Efficiency	Standard Efficiency With VFD	High Efficiency	High Efficiency with VFD	Premium Efficiency	Premium Efficiency with VFD
Capacity (tons)	190 to 550	170 to 200	210 to 530		240 to 400	
Sound pressure (dBA) without attenuation ¹	67 to 73	66 to 67	69 to 74	70 to 75	70 to 72	71 to 72
Power	60 Hz	60 Hz	60 Hz		60 Hz	
Refrigerant	R-134a	R-134	R-134a		R-134a	
Part load (IPLV)	13.2 to 14.0	17.3 to 17.7	14.0 to 14.7	18.0 to 18.9	15.9 to 16.2	18.8 to 19.4
Full load (EER)	9.6 to 10.1	9.9 to 10.4	10.3 to 10.9	9.6 to 10.2	11.4 to 12.2	11.0 to 11.8
Small unit footprint	Best	Best	Best	Better	Better	Good
First cost	Best	Good	Better	Good	Better	Good
Life cycle cost	Good	Best	Better	Better	Best	Best
Full load optimization	Good	Good	Better	Better	Best	Better
Part load optimization	Good	Best	Better	Best	Better	Best
Integration options	BACnet®, LonWorks®, or Modbus® communication					

1. Per AHRI Standard 370

Air-Cooled Chillers



Daikin Pathfinder® Introduction



Daikin Pathfinder® RapidRestore® & Fast Loading



Air-Cooled Chillers

Physical Data—Pathfinder® Standard Efficiency (Non-VFD)

AWS 190B through 225B, Standard Efficiency, non-VFD models

Data	AWS190BDS		AWS210BDS		AWS225BDS	
	Circuit 1	Circuit 2	Circuit 1	Circuit 2	Circuit 1	Circuit 2
Basic Data						
Unit Capacity @ AHRI tons (kW)	180.1 (633)		201.3 (708)		216.3 (760)	
Unit Operating Charge lbs (kg)	145 (66)	145 (66)	165 (75)	165 (75)	165 (75)	165 (75)
Unit Dimensions LxWxH, in. (mm)	245x88x100 (6220x2225x2548)		245x88x100 (6220x2225x2548)		245x88x100 (6220x2225x2548)	
Unit Operating Weight, lbs. (kg)	13072 (5930)		13788 (6255)		14335 (6503)	
Unit Shipping Weight, lbs (kg)	12529 (5684)		13245 (6008)		13792 (6256)	
Weight-Add for Copper Fins, lbs (kg)	1786 (810)		1786 (810)		1786 (810)	
Weight-Add for Louvered Panels, lbs (kg)	676 (307)		788 (357)		788 (357)	
Weight-Add for Sound Enclosures, lbs (kg)	477 (216)		477 (216)		477 (216)	
Weight-Add for PFCC option, lbs (kg)	160 (73)		160 (73)		160 (73)	
Compressors, Screw, Semi-Hermetic						
Nominal Capacity, tons (kW)	95 (334)	95 (334)	95 (334)	115 (404)	115 (404)	115 (404)
Minimum Capacity (% of Full Load)	15		15		15	
Oil charge per circuit, gallons (liters)	4.5 (17)	4.5 (17)	4.5 (17)	5.5 (21)	5.5 (21)	5.5 (21)
Condensers, High Efficiency Fin and Tube Type						
Pumpdown Capacity, lbs (kg)	208 (94)	208 (94)	250 (113)	250 (113)	250 (113)	250 (113)
Coil Inlet Face Area, sq. ft. (sq. m.)	123.1 (11.4)	123.1 (11.4)	147.7 (13.7)	147.7 (13.7)	147.7 (13.7)	147.7 (13.7)
Rows Deep/Fins per Inch	3 / 16	3 / 16	3 / 16	3 / 16	3 / 16	3 / 16
Condenser Fans, Direct-Drive Propeller Type						
Number of Fans per Circuit	5	5	6	6	6	6
Fan Diameter: 31.5 in. (800 mm)						
Fan Motor, hp (kW)	1.4 (1.05)		1.4 (1.05)		1.4 (1.05)	
Fan & Motor RPM	850		850		850	
Fan Tip Speed, fpm (m/s)	6984 (35)		6984 (35)		6984 (35)	
Airflow, cfm (l/s)	110850 (52315)		133020 (62778)		133020 (62778)	
Evaporator, Direct Expansion Shell and Tube						
Shell Diameter-Tube Length, in. (mm)	16x406 (406x2750)		16x108 (406x2750)		16x108 (406x2750)	
Water Volume, gallons (liters)	68 (258)		66 (251)		66 (251)	
Victaulic inlet/outlet connection in. (mm)	6 (168)		6 (168)		6 (168)	
Maximum Water Pressure, psi (kPa)	152 (1048)		152 (1048)		152 (1048)	
Maximum Refrigerant Pressure, psi (kPa)	325 (2241)		325 (2241)		325 (2241)	

NOTES: A 20 mesh strainer must be placed in the supply water line just prior to the inlet of the evaporator.
Care must be exercised when welding pipe or flanges to the evaporator to prevent any slag from entering the vessel.

AWS 250B through 290B, Standard Efficiency, non-VFD models

Data	AWS250BDS		AWS260BDS		AWS290BDS	
	Circuit 1	Circuit 2	Circuit 1	Circuit 2	Circuit 1	Circuit 2
Basic Data						
Unit Capacity @ AHRI tons (kW)	235.8 (829)		250.5 (881)		282.9 (995)	
Unit Operating Charge lbs (kg)	185 (84)	185 (84)	185 (84)	185 (84)	210 (95)	210 (95)
Unit Dimensions LxWxH, in. (mm)	280x88x100 (7121x2225x2548)		280x88x100 (7121x2225x2548)		316x88x100 (8022x2225x2548)	
Unit Operating Weight, lbs. (kg)	15188 (6890)		15188 (6890)		17491 (7934)	
Unit Shipping Weight, lbs (kg)	14645 (6643)		14645 (6643)		16624 (7541)	
Weight-Add for Copper Fins, lbs (kg)	2084 (945)		2084 (945)		2372 (1076)	
Weight-Add for Louvered Panels, lbs (kg)	900 (408)		900 (408)		1012 (459)	
Weight-Add for Sound Enclosures, lbs (kg)	477 (216)		477 (216)		477 (216)	
Weight-Add for PFCC option, lbs (kg)	160 (73)		160 (73)		160 (73)	
Compressors, Screw, Semi-Hermetic						
Nominal Capacity, tons (kW)	115 (404)	135 (475)	135 (475)	135 (475)	135 (475)	155 (545)
Minimum Capacity (% of Full Load)	15		15		15	
Oil charge per circuit, gallons (liters)	5.5 (21)	5.5 (21)	5.5 (21)	5.5 (21)	5.5 (21)	6 (23)
Condensers, High Efficiency Fin and Tube Type						
Pumpdown Capacity, lbs (kg)	291 (132)	291 (132)	291 (132)	291 (132)	333 (151)	333 (151)
Coil Inlet Face Area, sq. ft. (sq. m.)	172.3 (16.0)	172.3 (16.0)	172.3 (16.0)	172.3 (16.0)	196.9 (18.3)	196.9 (18.3)
Rows Deep/Fins per Inch	3 / 16	3 / 16	3 / 16	3 / 16	3 / 16	3 / 16
Condenser Fans, Direct-Drive Propeller Type						
Number of Fans per Circuit	7	7	7	7	8	8
Fan Diameter: 31.5 in. (800 mm)						
Fan Motor, hp (kW)	1.4 (1.05)		1.4 (1.05)		1.4 (1.05)	
Fan & Motor RPM	850		850		850	
Fan Tip Speed, fpm (m/s)	6984 (35)		6984 (35)		6984 (35)	
Airflow, cfm (l/s)	155190 (73241)		155190 (73241)		177360 (83704)	
Evaporator, Direct Expansion Shell and Tube						
Shell Diameter-Tube Length, in. (mm)	16x108 (406x2750)		16x108 (406x2750)		20x108 (508x2750)	
Water Volume, gallons (liters)	64 (243)		64 (243)		107 (403)	
Victaulic inlet/outlet connection in. (mm)	6 (168)		6 (168)		8 (219)	
Maximum Water Pressure, psi (kPa)	152 (1048)		152 (1048)		152 (1048)	
Maximum Refrigerant Pressure, psi (kPa)	325 (2241)		325 (2241)		325 (2241)	

NOTES: A 20 mesh strainer must be placed in the supply water line just prior to the inlet of the evaporator.
Care must be exercised when welding pipe or flanges to the evaporator to prevent any slag from entering the vessel.

Air-Cooled Chillers

AWS 310B through 375B, Standard Efficiency, non-VFD models

Data	AWS310BDS		AWS350BDS		AWS375BDS	
	Circuit 1	Circuit 2	Circuit 1	Circuit 2	Circuit 1	Circuit 2
Basic Data						
Unit Capacity @ AHRI tons (kW)	300.4 (1056)		340.6 (1197)		361.4 (1271)	
Unit Operating Charge lbs (kg)	215 (98)	215 (98)	265 (120)	265 (120)	265 (120)	265 (120)
Unit Dimensions LxWxH, in. (mm)	316x88x100 (8026x2225x2548)		387x88x100 (9823x2225x2548)		387x88x100 (9823x2225x2548)	
Unit Operating Weight, lbs. (kg)	18161 (8238)		19803 (8983)		19803 (8983)	
Unit Shipping Weight, lbs (kg)	17294 (7845)		18936 (8590)		18936 (8590)	
Weight-Add for Copper Fins, lbs (kg)	2372 (1076)		2968 (1346)		2968 (1346)	
Weight-Add for Louvered Panels, lbs (kg)	1012 (459)		1236 (561)		1236 (561)	
Weight-Add for Sound Enclosures, lbs (kg)	477 (216)		477 (216)		477 (216)	
Weight-Add for PFCC option, lbs (kg)	160 (73)		160 (73)		160 (73)	
Compressors, Screw, Semi-Hermetic						
Nominal Capacity, tons (kW)	155 (545)	155 (545)	155 (545)	185 (650)	185 (650)	185 (650)
Minimum Capacity (% of Full Load)	15		15		15	
Oil charge per circuit, gallons (liters)	6 (23)	6 (23)	6 (23)	6 (23)	6 (23)	6 (23)
Condensers, High Efficiency Fin and Tube Type						
Pumpdown Capacity, lbs (kg)	333 (151)	333 (151)	416 (189)	416 (189)	416 (189)	416 (189)
Coil Inlet Face Area, sq. ft. (sq. m.)	196.9 (18.3)	196.9 (18.3)	246.1 (22.8)	246.1 (22.8)	246.1 (22.8)	246.1 (22.8)
Rows Deep/Fins per Inch	3 / 16	3 / 16	3 / 16	3 / 16	3 / 16	3 / 16
Condenser Fans, Direct-Drive Propeller Type						
Number of Fans per Circuit Fan Diameter: 31.5 in. (800 mm)	8	8	10	10	10	10
Fan Motor, hp (kW)	1.4 (1.05)		1.4 (1.05)		1.4 (1.05)	
Fan & Motor RPM	850		850		850	
Fan Tip Speed, fpm (m/s)	6984 (35)		6984 (35)		6984 (35)	
Airflow, cfm (l/s)	177360 (83704)		221700 (104630)		221700 (104630)	
Evaporator, Direct Expansion Shell and Tube						
Shell Diameter-Tube Length, in. (mm)	20x108 (508x2750)		20x108 (508x2750)		20x108 (508x2750)	
Water Volume, gallons (liters)	107 (403)		102 (386)		102 (386)	
Victaulic inlet/outlet connection in. (mm)	8 (219)		8 (219)		8 (219)	
Maximum Water Pressure, psi (kPa)	152 (1048)		152 (1048)		152 (1048)	
Maximum Refrigerant Pressure, psi (kPa)	325 (2241)		325 (2241)		325 (2241)	

NOTES: A 20 mesh strainer must be placed in the supply water line just prior to the inlet of the evaporator.
Care must be exercised when welding pipe or flanges to the evaporator to prevent any slag from entering the vessel.

AWS 400B through 450B, Standard Efficiency, non-VFD models

Data	AWS400BTS			AWS425BTS			AWS450BTS		
	Circuit 1	Circuit 2	Circuit 3	Circuit 1	Circuit 2	Circuit 3	Circuit 1	Circuit 2	Circuit 3
Basic Data									
Unit Capacity @ AHRI tons (kW)	398.3 (1400)			418.7 (1472)			441.4 (1552)		
Unit Operating Charge lbs (kg)	185 (84)	185 (84)	220 (100)	185 (84)	185 (84)	220 (100)	210 (95)	210 (95)	220 (100)
Unit Dimensions LxWxH, in. (mm)	438x88x100 (11123x2225x2548)			438x88x100 (11123x2225x2548)			473x88x100 (12024x2225x2548)		
Unit Operating Weight, lbs. (kg)	24260 (11005)			24931 (11309)			26418 (11984)		
Unit Shipping Weight, lbs (kg)	22861 (10370)			23532 (10674)			25019 (11349)		
Weight-Add for Copper Fins, lbs (kg)	3256 (1477)			3256 (1477)			3553 (1612)		
Weight-Add for Louvered Panels, lbs (kg)	1348 (611)			1348 (611)			1460 (662)		
Weight-Add for Sound Enclosures, lbs (kg)	776 (352)			776 (352)			776 (352)		
Weight-Add for PFCC option, lbs (kg)	120 (55)			120 (55)			120 (55)		
Compressors, Screw, Semi-Hermetic									
Nominal Capacity, tons (kW)	135 (475)	135 (475)	135 (475)	135 (475)	135 (475)	155 (545)	135 (475)	155 (545)	155 (545)
Minimum Capacity (% of Full Load)	8			8			8		
Oil charge per circuit, gallons (liters)	5.5 (21)	5.5 (21)	5.5 (21)	5.5 (21)	5.5 (21)	6 (23)	5.5 (21)	6 (23)	6 (23)
Condensers, High Efficiency Fin and Tube Type									
Pumpdown Capacity, lbs (kg)	291 (132)	291 (132)	333 (151)	291 (132)	291 (132)	333 (151)	333 (151)	333 (151)	333 (151)
Coil Inlet Face Area, sq. ft. (sq. m.)	172.3 (16.0)	172.3 (16.0)	196.9 (18.3)	172.3 (16.0)	172.3 (16.0)	196.9 (18.3)	196.9 (18.3)	196.9 (18.3)	196.9 (18.3)
Rows Deep/Fins per Inch	3 / 16	3 / 16	3 / 16	3 / 16	3 / 16	3 / 16	3 / 16	3 / 16	3 / 16
Condenser Fans, Direct-Drive Propeller Type									
Number of Fans per Circuit Fan Diameter: 31.5 in. (800 mm)	7	7	8	7	7	8	8	8	8
Fan Motor, hp (kW)	1.4 (1.05)			1.4 (1.05)			1.4 (1.05)		
Fan & Motor RPM	850			850			850		
Fan Tip Speed, fpm (m/s)	6984 (35)			6984 (35)			6984 (35)		
Airflow, cfm (l/s)	266040 (125556)			243870 (115094)			266040 (125556)		
Evaporator, Direct Expansion Shell and Tube									
Shell Diameter-Tube Length, in. (mm)	26x130 (660x3300)			26x130 (660x3300)			26x130 (660x3300)		
Water Volume, gallons (liters)	225 (850)			225 (850)			225 (850)		
Victaulic inlet/outlet connection in. (mm)	10 (273)			10 (273)			10 (273)		
Maximum Water Pressure, psi (kPa)	152 (1048)			152 (1048)			152 (1048)		
Maximum Refrigerant Pressure, psi (kPa)	325 (2241)			325 (2241)			325 (2241)		

NOTES: A 20 mesh strainer must be placed in the supply water line just prior to the inlet of the evaporator.
Care must be exercised when welding pipe or flanges to the evaporator to prevent any slag from entering the vessel.

Air-Cooled Chillers

AWS 470B through 525B, Standard Efficiency, non-VFD models

Data	AWS470BTS			AWS500BTS			AWS525BTS		
	Circuit 1	Circuit 2	Circuit 3	Circuit 1	Circuit 2	Circuit 3	Circuit 1	Circuit 2	Circuit 3
Basic Data									
Unit Capacity @ AHRI tons (kW)	459.2 (1615)			488.3 (1717)			517.7 (1820)		
Unit Operating Charge lbs (kg)	210 (95)	210 (95)	220 (100)	210 (95)	210 (95)	280 (127)	265 (120)	265 (120)	220 (100)
Unit Dimensions LxWxH, in. (mm)	473x88x100 (12024x2225x2548)			509x88x100 (12921x2225x2548)			544x88x100 (13823x2225x2548)		
Unit Operating Weight, lbs. (kg)	27143 (12312)			27902 (12657)			28901 (13110)		
Unit Shipping Weight, lbs (kg)	25744 (11678)			26503 (12022)			27502 (12475)		
Weight-Add for Copper Fins, lbs (kg)	3553 (1612)			3870 (1755)			4168 (1891)		
Weight-Add for Louvered Panels, lbs (kg)	1460 (662)			1572 (713)			1684 (764)		
Weight-Add for Sound Enclosures, lbs (kg)	776 (352)			776 (352)			776 (352)		
Weight-Add for PFCC option, lbs (kg)	120 (55)			120 (55)			120 (55)		
Compressors, Screw, Semi-Hermetic									
Nominal Capacity, tons (kW)	155 (545)	155 (545)	155 (545)	155 (545)	155 (545)	185 (650)	185 (650)	185 (650)	155 (545)
Minimum Capacity (% of Full Load)	8			8			8		
Oil charge per circuit, gallons (liters)	6 (23)	6 (23)	6 (23)	6 (23)	6 (23)	6 (23)	6 (23)	6 (23)	6 (23)
Condensers, High Efficiency Fin and Tube Type									
Pumpdown Capacity, lbs (kg)	333 (151)	333 (151)	333 (151)	333 (151)	333 (151)	416 (189)	416 (189)	416 (189)	333 (151)
Coil Inlet Face Area, sq. ft. (sq. m.)	196.9 (18.3)	196.9 (18.3)	196.9 (18.3)	196.9 (18.3)	196.9 (18.3)	246.1 (22.8)	246.1 (22.8)	246.1 (22.8)	196.9 (18.3)
Rows Deep/Fins per Inch	3 / 16	3 / 16	3 / 16	3 / 16	3 / 16	3 / 16	3 / 16	3 / 16	3 / 16
Condenser Fans, Direct-Drive Propeller Type									
Number of Fans per Circuit	8	8	8	8	8	10	10	10	8
Fan Diameter: 31.5 in. (800 mm)									
Fan Motor, hp (kW)	1.4 (1.05)			1.4 (1.05)			1.4 (1.05)		
Fan & Motor RPM	850			850			850		
Fan Tip Speed, fpm (m/s)	6984 (35)			6984 (35)			6984 (35)		
Airflow, cfm (l/s)	266040 (125556)			288210 (136019)			310380 (146482)		
Evaporator, Direct Expansion Shell and Tube									
Shell Diameter-Tube Length, in. (mm)	26x130 / (660x3300)			26x130 / (660x3300)			26x130 / (660x3300)		
Water Volume, gallons (liters)	220 (831)			220 (831)			220 (831)		
Victaulic inlet/outlet connection in. (mm)	10 (273)			10 (273)			10 (273)		
Maximum Water Pressure, psi (kPa)	152 (1048)			152 (1048)			152 (1048)		
Maximum Refrigerant Pressure, psi (kPa)	325 (2241)			325 (2241)			325 (2241)		

NOTES: A 20 mesh strainer must be placed in the supply water line just prior to the inlet of the evaporator. Care must be exercised when welding pipe or flanges to the evaporator to prevent any slag from entering the vessel.

AWS 550B, Standard Efficiency, non-VFD models

Data	AWS550BTS		
	Circuit 1	Circuit 2	Circuit 3
Basic Data			
Unit Capacity @ AHRI tons (kW)	547.3 (1924)		
Unit Operating Charge lbs (kg)	270 (122)	270 (122)	280 (127)
Unit Dimensions LxWxH, in. (mm)	580x88x100 (14722x2225x2548)		
Unit Operating Weight, lbs. (kg)	29643 (13446)		
Unit Shipping Weight, lbs (kg)	28244 (12812)		
Weight-Add for Copper Fins, lbs (kg)	4466 (2026)		
Weight-Add for Louvered Panels, lbs (kg)	1796 (815)		
Weight-Add for Sound Enclosures, lbs (kg)	776 (352)		
Weight-Add for PFCC option, lbs (kg)	120 (55)		
Compressors, Screw, Semi-Hermetic			
Nominal Capacity, tons (kW)	185 (650)	185 (650)	185 (650)
Minimum Capacity (% of Full Load)	8		
Oil charge per circuit, gallons (liters)	6 (23)	6 (23)	6 (23)
Condensers, High Efficiency Fin and Tube Type			
Pumpdown Capacity, lbs (kg)	416 (189)	416 (189)	416 (189)
Coil Inlet Face Area, sq. ft. (sq. m.)	246.1 (22.8)	246.1 (22.8)	246.1 (22.8)
Rows Deep/Fins per Inch	3 / 16	3 / 16	3 / 16
Condenser Fans, Direct-Drive Propeller Type			
Number of Fans per Circuit	10	10	10
Fan Diameter: 31.5 in. (800 mm)			
Fan Motor, hp (kW)	1.4 (1.05)		
Fan & Motor RPM	850		
Fan Tip Speed, fpm (m/s)	6984 (35)		
Airflow, cfm (l/s)	332550 (156945)		
Evaporator, Direct Expansion Shell and Tube			
Shell Diameter-Tube Length, in. (mm)	26x130 / (660x3300)		
Water Volume, gallons (liters)	220 (831)		
Victaulic inlet/outlet connection in. (mm)	10 (273)		
Maximum Water Pressure, psi (kPa)	152 (1048)		
Maximum Refrigerant Pressure, psi (kPa)	325 (2241)		

NOTES: A 20 mesh strainer must be placed in the supply water line just prior to the inlet of the evaporator. Care must be exercised when welding pipe or flanges to the evaporator to prevent any slag from entering the vessel.

Air-Cooled Chillers

Physical Data—Pathfinder® High Efficiency (Non-VFD)

AWS 210B through 280B, High Efficiency, non-VFD models

Data	AWS210BDH		AWS230BDH		AWS250BDH		AWS280BDH	
	Circuit 1	Circuit 2	Circuit 1	Circuit 2	Circuit 1	Circuit 2	Circuit 1	Circuit 2
Basic Data								
Unit Capacity @ AHRI tons (kW)	205.7 (723)		225.2 (792)		240.6 (846)		271.9 (956)	
Unit Operating Charge lbs (kg)	160 (73)	160 (73)	180 (82)	180 (82)	180 (82)	180 (82)	230 (104)	250 (113)
Unit Dimensions LxWxH, in. (mm)	245x88x100 (6220x2225x2548)		280x88x100 (7121x2225x2548)		280x88x100 (7121x2225x2548)		316x88x100 (8022x2225x2548)	
Unit Operating Weight, lbs. (kg)	13653 (6193)		15165 (6879)		15825 (7179)		17461 (7921)	
Unit Shipping Weight, lbs (kg)	13110 (5947)		14622 (6633)		15282 (6932)		16594 (7527)	
Weight-Add for Copper Fins, lbs (kg)	1876 (851)		2084 (945)		2084 (945)		2372 (1076)	
Weight-Add for Louvered Panels, lbs (kg)	788 (357)		900 (408)		900 (408)		1012 (459)	
Weight-Add for Sound Enclosures, lbs (kg)	477 (216)		477 (216)		477 (216)		477 (216)	
Weight-Add for PFCC option, lbs (kg)	160 (73)		160 (73)		160 (73)		160 (73)	
Compressors, Screw, Semi-Hermetic								
Nominal Capacity, tons (kW)	105 (369)	105 (369)	105 (369)	125 (439)	125 (439)	125 (439)	125 (439)	150 (528)
Minimum Capacity (% of Full Load)	15		15		15		15	
Oil charge per circuit, gallons (liters)	4.5 (17)	4.5 (17)	4.5 (17)	5.5 (21)	5.5 (21)	5.5 (21)	5.5 (21)	5.5 (21)
Condensers, High Efficiency Fin and Tube Type								
Pumpdown Capacity, lbs (kg)	250 (113)	250 (113)	291 (132)	291 (132)	291 (132)	291 (132)	333 (151)	333 (151)
Coil Inlet Face Area, sq. ft. (sq. m.)	147.7 (13.7)	147.7 (13.7)	172.3 (16.0)	172.3 (16.0)	172.3 (16.0)	172.3 (16.0)	196.9 (18.3)	196.9 (18.3)
Rows Deep/Fins per Inch	3 / 16	3 / 16	3 / 16	3 / 16	3 / 16	3 / 16	3 / 16	3 / 16
Condenser Fans, Direct-Drive Propeller Type								
Number of Fans per Circuit Fan Diameter: 31.5 in. (800 mm)	6	6	7	7	7	7	8	8
Fan Motor, hp (kW)	1.4 (1.05)		1.4 (1.05)		1.4 (1.05)		1.4 (1.05)	
Fan & Motor RPM	850		850		850		850	
Fan Tip Speed, fpm (m/s)	6984 (35)		6984 (35)		6984 (35)		6984 (35)	
Airflow, cfm (l/s)	133020 (62778)		155190 (73241)		155190 (73241)		177360 (83704)	
Evaporator, Direct Expansion Shell and Tube								
Shell Diameter-Tube Length, in. (mm)	16x108 / (406x2750)		16x108 / (406x2750)		16x108 / (406x2750)		20x108 / (508x2750)	
Water Volume, gallons (liters)	66 (251)		64 (243)		64 (243)		107 (403)	
Victaulic inlet/outlet connection in. (mm)	6 (168)		6 (168)		6 (168)		8 (219)	
Maximum Water Pressure, psi (kPa)	152 (1048)		152 (1048)		152 (1048)		152 (1048)	
Maximum Refrigerant Pressure, psi (kPa)	325 (2241)		325 (2241)		325 (2241)		325 (2241)	

NOTES: A 20 mesh strainer must be placed in the supply water line just prior to the inlet of the evaporator.
Care must be exercised when welding pipe or flanges to the evaporator to prevent any slag from entering the vessel.

AWS 300B through 390B, High Efficiency, non-VFD models

Data	AWS300BDH		AWS330BDH		AWS350BDH		AWS390BDH	
	Circuit 1	Circuit 2	Circuit 1	Circuit 2	Circuit 1	Circuit 2	Circuit 1	Circuit 2
Basic Data								
Unit Capacity @ AHRI tons (kW)	288.7 (1015)		327.3 (1151)		348.1 (1224)		378.7 (1332)	
Unit Operating Charge lbs (kg)	250 (113)	250 (113)	260 (118)	285 (129)	285 (129)	285 (129)	285 (129)	331 (150)
Unit Dimensions LxWxH, in. (mm)	316x88x100 (8022x2225x2548)		387x88x100 (9823x2225x2548)		387x88x100 (9823x2225x2548)		438x88x100 (11123x2225x2548)	
Unit Operating Weight, lbs. (kg)	17461 (7921)		19764 (8965)		20444 (9274)		21864 (9918)	
Unit Shipping Weight, lbs (kg)	16594 (7527)		18897 (8572)		19577 (8880)		20997 (9525)	
Weight-Add for Copper Fins, lbs (kg)	2372 (1076)		2968 (1346)		2968 (1346)		3256 (1477)	
Weight-Add for Louvered Panels, lbs (kg)	1012 (459)		1236 (561)		1236 (561)		1348 (611)	
Weight-Add for Sound Enclosures, lbs (kg)	477 (216)		477 (216)		477 (216)		477 (216)	
Weight-Add for PFCC option, lbs (kg)	160 (73)		160 (73)		160 (73)		160 (73)	
Compressors, Screw, Semi-Hermetic								
Nominal Capacity, tons (kW)	150 (528)	150 (528)	150 (528)	175 (615)	175 (615)	175 (615)	175 (615)	205 (721)
Minimum Capacity (% of Full Load)	15		15		15		15	
Oil charge per circuit, gallons (liters)	5.5 (21)	5.5 (21)	5.5 (21)	6 (23)	6 (23)	6 (23)	6 (23)	6 (23)
Condensers, High Efficiency Fin and Tube Type								
Pumpdown Capacity, lbs (kg)	333 (151)	333 (151)	416 (189)	416 (189)	416 (189)	416 (189)	416 (189)	500 (227)
Coil Inlet Face Area, sq. ft. (sq. m.)	196.9 (18.3)	196.9 (18.3)	246.1 (22.8)	246.1 (22.8)	246.1 (22.8)	246.1 (22.8)	246.1 (22.8)	295.3 (27.4)
Rows Deep/Fins per Inch	3 / 16	3 / 16	3 / 16	3 / 16	3 / 16	3 / 16	3 / 16	3 / 16
Condenser Fans, Direct-Drive Propeller Type								
Number of Fans per Circuit Fan Diameter: 31.5 in. (800 mm)	8	8	10	10	10	10	10	12
Fan Motor, hp (kW)	1.4 (1.05)		1.4 (1.05)		1.4 (1.05)		1.4 (1.05)	
Fan & Motor RPM	850		850		850		850	
Fan Tip Speed, fpm (m/s)	6984 (35)		6984 (35)		6984 (35)		6984 (35)	
Airflow, cfm (l/s)	177360 (83704)		221700 (104630)		221700 (104630)		243870 (115094)	
Evaporator, Direct Expansion Shell and Tube								
Shell Diameter-Tube Length, in. (mm)	20x108 / (508x2750)		20x108 / (508x2750)		20x108 / (508x2750)		20x108 / (508x2750)	
Water Volume, gallons (liters)	107 (403)		102 (386)		102 (386)		100 (377)	
Victaulic inlet/outlet connection in. (mm)	8 (219)		8 (219)		8 (219)		8 (219)	
Maximum Water Pressure, psi (kPa)	152 (1048)		152 (1048)		152 (1048)		152 (1048)	
Maximum Refrigerant Pressure, psi (kPa)	325 (2241)		325 (2241)		325 (2241)		325 (2241)	

NOTES: A 20 mesh strainer must be placed in the supply water line just prior to the inlet of the evaporator.
Care must be exercised when welding pipe or flanges to the evaporator to prevent any slag from entering the vessel.

Air-Cooled Chillers

AWS 410B through AWS 450B, High Efficiency, non-VFD models

Data	AWS410BDH		AWS450BTH		
	Circuit 1	Circuit 2	Circuit 1	Circuit 2	Circuit 3
Basic Data					
Unit Capacity @ AHRI tons (kW)	409.8 (1441)		446.3 (1569)		
Unit Operating Charge lbs (kg)	331 (150)	331 (150)	250 (113)	250 (113)	250 (113)
Unit Dimensions LxWxH, in. (mm)	473x88x101 (12024x2225x2548)		473x88x100 (12024x2225x2548)		
Unit Operating Weight, lbs. (kg)	22657 (10278)		26057 (11820)		
Unit Shipping Weight, lbs (kg)	21790 (9884)		24658 (11185)		
Weight-Add for Copper Fins, lbs (kg)	3553 (1612)		3553 (1612)		
Weight-Add for Louvered Panels, lbs (kg)	1460 (662)		1460 (662)		
Weight-Add for Sound Enclosures, lbs (kg)	477 (216)		776 (352)		
Weight-Add for PFCC option, lbs (kg)	160 (73)		120 (55)		
Compressors, Screw, Semi-Hermetic					
Nominal Capacity, tons (kW)	205 (721)	205 (721)	150 (528)	150 (528)	150 (528)
Minimum Capacity (% of Full Load)	15		8		
Oil charge per circuit, gallons (liters)	6 (23)	6 (23)	5.5 (21)	5.5 (21)	5.5 (21)
Condensers, High Efficiency Fin and Tube Type					
Pumpdown Capacity, lbs (kg)	500 (227)	500 (227)	333 (151)	333 (151)	333 (151)
Coil Inlet Face Area, sq. ft. (sq. m.)	295.3 (27.4)	295.3 (27.4)	196.9 (18.3)	196.9 (18.3)	196.9 (18.3)
Rows Deep/Fins per Inch	3 / 16	3 / 16	3 / 16	3 / 16	3 / 16
Condenser Fans, Direct-Drive Propeller Type					
Number of Fans per Circuit	12	12	8	8	8
Fan Diameter: 31.5 in. (800 mm)					
Fan Motor, hp (kW)	1.4 (1.05)		1.4 (1.05)		
Fan & Motor RPM	850		850		
Fan Tip Speed, fpm (m/s)	6984 (35)		6984 (35)		
Airflow, cfm (l/s)	266040 (125556)		266040 (125556)		
Evaporator, Direct Expansion Shell and Tube					
Shell Diameter-Tube Length, in. (mm)	20x108 / (508x2750)		26x130 / (660x3300)		
Water Volume, gallons (liters)	100 (377)		225 (850)		
Victaulic inlet/outlet connection in. (mm)	8 (219)		10 (273)		
Maximum Water Pressure, psi (kPa)	152 (1048)		152 (1048)		
Maximum Refrigerant Pressure, psi (kPa)	325 (2241)		325 (2241)		

NOTES: A 20 mesh strainer must be placed in the supply water line just prior to the inlet of the evaporator. Care must be exercised when welding pipe or flanges to the evaporator to prevent any slag from entering the vessel.

AWS 475B through 530B, High Efficiency, non-VFD models

Data	AWS475BTH			AWS500BTH			AWS530BTH		
	Circuit 1	Circuit 2	Circuit 3	Circuit 1	Circuit 2	Circuit 3	Circuit 1	Circuit 2	Circuit 3
Basic Data									
Unit Capacity @ AHRI tons (kW)	470.3 (1654)			499.4 (1756)			528.3 (1857)		
Unit Operating Charge lbs (kg)	250 (113)	250 (113)	295 (134)	295 (134)	295 (134)	250 (113)	295 (134)	295 (134)	295 (134)
Unit Dimensions LxWxH, in. (mm)	509x88x100 (12921x2225x2548)			544x88x100 (13823x2225x2548)			580x88x100 (14722x2225x2548)		
Unit Operating Weight, lbs. (kg)	27542 (12493)			29181 (13237)			30608 (13884)		
Unit Shipping Weight, lbs (kg)	26143 (11859)			27782 (12602)			29209 (13249)		
Weight-Add for Copper Fins, lbs (kg)	3870 (1755)			4168 (1891)			4466 (2026)		
Weight-Add for Louvered Panels, lbs (kg)	1572 (713)			1684 (764)			1796 (815)		
Weight-Add for Sound Enclosures, lbs (kg)	776 (352)			776 (352)			776 (352)		
Weight-Add for PFCC option, lbs (kg)	120 (55)			120 (55)			120 (55)		
Compressors, Screw, Semi-Hermetic									
Nominal Capacity, tons (kW)	150 (528)	150 (528)	175 (615)	175 (615)	175 (615)	150 (528)	175 (615)	175 (615)	175 (615)
Minimum Capacity (% of Full Load)	8			8			8		
Oil charge per circuit, gallons (liters)	5.5 (21)	5.5 (21)	6 (23)	6 (23)	6 (23)	5.5 (21)	6 (23)	6 (23)	6 (23)
Condensers, High Efficiency Fin and Tube Type									
Pumpdown Capacity, lbs (kg)	333 (151)	333 (151)	416 (189)	416 (189)	416 (189)	333 (151)	416 (189)	416 (189)	416 (189)
Coil Inlet Face Area, sq. ft. (sq. m.)	196.9 (18.3)	196.9 (18.3)	246.1 (22.8)	246.1 (22.8)	246.1 (22.8)	196.9 (18.3)	246.1 (22.8)	246.1 (22.8)	246.1 (22.8)
Rows Deep/Fins per Inch	3 / 16	3 / 16	3 / 16	3 / 16	3 / 16	3 / 16	3 / 16	3 / 16	3 / 16
Condenser Fans, Direct-Drive Propeller Type									
Number of Fans per Circuit	8	8	10	10	10	8	10	10	10
Fan Diameter: 31.5 in. (800 mm)									
Fan Motor, hp (kW)	1.4 (1.05)			1.4 (1.05)			1.4 (1.05)		
Fan & Motor RPM	850			850			850		
Fan Tip Speed, fpm (m/s)	6984 (35)			6984 (35)			6984 (35)		
Airflow, cfm (l/s)	288210 (136019)			310380 (146482)			332550 (156945)		
Evaporator, Direct Expansion Shell and Tube									
Shell Diameter-Tube Length, in. (mm)	26x130 / (660x3300)			26x130 / (660x3300)			26x130 / (660x3300)		
Water Volume, gallons (liters)	220 (831)			220 (831)			220 (831)		
Victaulic inlet/outlet connection in. (mm)	10 (273)			10 (273)			10 (273)		
Maximum Water Pressure, psi (kPa)	152 (1048)			152 (1048)			152 (1048)		
Maximum Refrigerant Pressure, psi (kPa)	325 (2241)			325 (2241)			325 (2241)		

NOTES: A 20 mesh strainer must be placed in the supply water line just prior to the inlet of the evaporator. Care must be exercised when welding pipe or flanges to the evaporator to prevent any slag from entering the vessel.

Air-Cooled Chillers

Physical Data—Pathfinder® Premium Efficiency (Non-VFD)

AWS 240B through 310B, Premium Efficiency, non-VFD models

Data	AWS240BDP		AWS265BDP		AWS290BDP		AWS310BDP	
	Circuit 1	Circuit 2	Circuit 1	Circuit 2	Circuit 1	Circuit 2	Circuit 1	Circuit 2
Basic Data								
Unit Capacity @ AHRI tons (kW)	232.8 (818)		256.4 (901)		277.5 (976)		303.9 (1068)	
Unit Operating Charge lbs (kg)	200 (91)	200 (91)	225 (102)	225 (102)	(235) (107)	(235) (107)	250 (113)	250 (113)
Unit Dimensions LxWxH, in. (mm)	316x88x100 (8022x2225x2548)		351x88x100 (8923x2225x2548)		351x88x100 (8923x2225x2548)		387x88x100 (9823x2225x2545)	
Unit Operating Weight, lbs. (kg)	17210 (7807)		18631 (8451)		20722 (9400)		21559 (9779)	
Unit Shipping Weight, lbs (kg)	15958 (7239)		17379 (7883)		19069 (8650)		19906 (9030)	
Weight-Add for Copper Fins, lbs (kg)	2372 (1076)		2679 (1215)		2679 (1215)		2968 (1346)	
Weight-Add for Louvered Panels, lbs (kg)	1012 (459)		1124 (510)		1124 (510)		1236 (561)	
Weight-Add for Sound Enclosures, lbs (kg)	477 (216)		477 (216)		477 (216)		477 (216)	
Weight-Add for PFCC option, lbs (kg)	160 (73)		160 (73)		160 (73)		160 (73)	
Compressors, Screw, Semi-Hermetic								
Nominal Capacity, tons (kW)	105 (369)	105 (369)	105 (369)	125 (439)	125 (439)	125 (439)	125 (439)	150 (528)
Minimum Capacity (% of Full Load)	15		15		15		15	
Oil charge per circuit, gallons (liters)	4.5 (17)	4.5 (17)	4.5 (17)	5.5 (21)	5.5 (21)	5.5 (21)	5.5 (21)	5.5 (21)
Condensers, High Efficiency Fin and Tube Type								
Pumpdown Capacity, lbs (kg)	333 (151)	333 (151)	375 (170)	375 (170)	375 (170)	375 (170)	416 (189)	416 (189)
Coil Inlet Face Area, sq. ft. (sq. m.)	196.9 (18.3)	196.9 (18.3)	221.5 (20.6)	221.5 (20.6)	221.5 (20.6)	221.5 (20.6)	246.1 (22.8)	246.1 (22.8)
Rows Deep/Fins per Inch	3 / 16	3 / 16	3 / 16	3 / 16	3 / 16	3 / 16	3 / 16	3 / 16
Condenser Fans, Direct-Drive Propeller Type								
Number of Fans per Circuit Fan Diameter: 31.5 in. (800 mm)	8	8	9	9	9	9	10	10
Fan Motor, hp (kW)	1.4 (1.05)		1.4 (1.05)		1.4 (1.05)		1.4 (1.05)	
Fan & Motor RPM	850		850		850		850	
Fan Tip Speed, fpm (m/s)	6984 (35)		6984 (35)		6984 (35)		6984 (35)	
Airflow, cfm (l/s)	177360 (83704)		199530 (94167)		199530 (94167)		221700 (104630)	
Evaporator, Direct Expansion Shell and Tube								
Shell Diameter-Tube Length, in. (mm)	20x154 / (508x3900)		20x154 / (508x3900)		26x154 / (660x3900)		26x154 / (660x3900)	
Water Volume, gallons (liters)	158 (599)		158 (599)		276 (1043)		276 (1043)	
Victaulic inlet/outlet connection in. (mm)	8 (2199)		8 (219)		10 (273)		10 (273)	
Maximum Water Pressure, psi (kPa)	152 (1048)		152 (1048)		152 (1048)		152 (1048)	
Maximum Refrigerant Pressure, psi (kPa)	325 (2241)		325 (2241)		325 (2241)		325 (2241)	

NOTES: A 20 mesh strainer must be placed in the supply water line just prior to the inlet of the evaporator.
Care must be exercised when welding pipe or flanges to the evaporator to prevent any slag from entering the vessel.

AWS 330B through 400B, Premium Efficiency, non-VFD models

Data	AWS330BDP		AWS365BDP		AWS400BDP	
	Circuit 1	Circuit 2	Circuit 1	Circuit 2	Circuit 1	Circuit 2
Basic Data						
Unit Capacity @ AHRI tons (kW)	324.9 (1142)		355 (1248)		385.4 (1355)	
Unit Operating Charge lbs (kg)	260 (118)	260 (118)	260 (118)	300 (136)	310 (141)	310 (141)
Unit Dimensions LxWxH, in. (mm)	387x88x100 (9823x2225x2545)		438x88x100 (11123x2225x2548)		473x88x100 (12024x2225x2548)	
Unit Operating Weight, lbs. (kg)	21559 (9779)		23659 (10732)		25093 (11382)	
Unit Shipping Weight, lbs (kg)	19906 (9030)		22006 (9982)		23440 (10633)	
Weight-Add for Copper Fins, lbs (kg)	2968 (1346)		3256 (1477)		3553 (1612)	
Weight-Add for Louvered Panels, lbs (kg)	1236 (561)		1348 (611)		1460 (662)	
Weight-Add for Sound Enclosures, lbs (kg)	477 (216)		477 (216)		477 (216)	
Weight-Add for PFCC option, lbs (kg)	160 (73)		160 (73)		160 (73)	
Compressors, Screw, Semi-Hermetic						
Nominal Capacity, tons (kW)	150 (528)	150 (528)	150 (528)	175 (615)	175 (615)	175 (615)
Minimum Capacity (% of Full Load)	15		15		15	
Oil charge per circuit, gallons (liters)	5.5 (21)	5.5 (21)	5.5 (21)	6 (23)	6 (23)	6 (23)
Condensers, High Efficiency Fin and Tube Type						
Pumpdown Capacity, lbs (kg)	416 (189)	416 (189)	416 (189)	500 (227)	500 (227)	500 (227)
Coil Inlet Face Area, sq. ft. (sq. m.)	246.1 (22.8)	246.1 (22.8)	246.1 (22.8)	295.3 (27.4)	295.3 (27.4)	295.3 (27.4)
Rows Deep/Fins per Inch	3 / 16	3 / 16	3 / 16	3 / 16	3 / 16	3 / 16
Condenser Fans, Direct-Drive Propeller Type						
Number of Fans per Circuit Fan Diameter: 31.5 in. (800 mm)	10	10	10	12	12	12
Fan Motor, hp (kW)	1.4 (1.05)		1.4 (1.05)		1.4 (1.05)	
Fan & Motor RPM	850		850		850	
Fan Tip Speed, fpm (m/s)	6984 (35)		6984 (35)		6984 (35)	
Airflow, cfm (l/s)	221700 (104630)		243870 (115093)		266040 (125556)	
Evaporator, Direct Expansion Shell And Tube						
Shell Diameter-Tube Length, in. (mm)	26x154 / (660x3900)		26x154 / (660x3900)		26x154 / (660x3900)	
Water Volume, gallons (liters)	259 (979)		259 (979)		259 (979)	
Victaulic inlet/outlet connection in. (mm)	10 (273)		10 (273)		10 (273)	
Maximum Water Pressure, psi (kPa)	152 (1048)		152 (1048)		152 (1048)	
Maximum Refrigerant Pressure, psi (kPa)	325 (2241)		325 (2241)		325 (2241)	

NOTES: A 20 mesh strainer must be placed in the supply water line just prior to the inlet of the evaporator.
Care must be exercised when welding pipe or flanges to the evaporator to prevent any slag from entering the vessel.

Air-Cooled Chillers

Physical Data—Pathfinder® Standard Efficiency (VFD)

AWS 170B through 200B, Standard Efficiency, VFD models

Data	AWS170BDS VFD		AWS190BDS VFD		AWS200BDS VFD	
	Circuit 1	Circuit 2	Circuit 1	Circuit 2	Circuit 1	Circuit 2
Basic Data						
Unit Capacity @ AHRI tons (kW)	162.6 (572)		181.3 (637)		195.1 (686)	
Unit Operating Charge lbs (kg)	145 (66)	145 (66)	165 (75)	165 (75)	165 (75)	165 (75)
Unit Dimensions LxWxH, in. (mm)	268x88x100 (6803x2225x2548)		268x88x100 (6803x2225x2548)		268x88x100 (6803x2225x2548)	
Unit Operating Weight, lbs. (kg)	13660 (6196)		14944 (6779)		14971 (6791)	
Unit Shipping Weight, lbs (kg)	13117 (5950)		14401 (6532)		14428 (6544)	
Weight-Add for Copper Fins	1776 (806)		1776 (806)		1776 (806)	
Weight-Add for Louvered Panels	676 (307)		788 (357)		788 (357)	
Compressors, Screw, Semi-Hermetic						
Nominal Capacity, tons (kW)	95 (334)	95 (334)	95 (334)	115 (404)	115 (404)	115 (404)
Minimum Capacity (% of Full Load)	20		20		20	
Oil charge per circuit, gallons (liters)	4.5 (17)	4.5 (17)	4.5 (17)	5.5 (21)	5.5 (21)	5.5 (21)
Condensers, High Efficiency Fin and Tube Type						
Pumpdown Capacity, lbs (kg)	208 (94)	208 (94)	250 (113)	250 (113)	250 (113)	250 (113)
Coil Inlet Face Area, sq. ft. (sq. m.)	123.1 (11.4)	123.1 (11.4)	147.7 (13.7)	147.7 (13.7)	147.7 (13.7)	147.7 (13.7)
Rows Deep/Fins per Inch	3 / 16	3 / 16	3 / 16	3 / 16	3 / 16	3 / 16
Condenser Fans, Direct-Drive Propeller Type						
Number of Fans per Circuit	5	5	6	6	6	6
Fan Diameter: 31.5 in. (800 mm)						
Fan Motor, hp (kW)	1.4 (1.05)		1.4 (1.05)		1.4 (1.05)	
Fan & Motor RPM	850		850		850	
Fan Tip Speed, fpm (m/s)	6984 (35)		6984 (35)		6984 (35)	
Airflow, cfm (l/s)	110850 (52315)		133020 (62778)		133020 (62778)	
Evaporator, Direct Expansion Shell and Tube						
Shell Diameter-Tube Length, in. (mm)	16x108 (406x2750)		16x108 (406x2750)		16x108 (406x2750)	
Water Volume, gallons (liters)	68 (258)		68 (258)		66 (251)	
Victaulic inlet/outlet connection in. (mm)	6 (168)		6 (168)		6 (168)	
Maximum Water Pressure, psi (kPa)	152 (1048)		152 (1048)		152 (1048)	
Maximum Refrigerant Pressure, psi (kPa)	325 (2241)		325 (2241)		325 (2241)	

NOTES: A 20 mesh strainer must be placed in the supply water line just prior to the inlet of the evaporator.
Care must be exercised when welding pipe or flanges to the evaporator to prevent any slag from entering the vessel.

Physical Data—Pathfinder® High Efficiency (VFD)

AWS 210B through 280B, High Efficiency, VFD models

Data	AWS210BDH VFD		AWS230BDH VFD		AWS250BDH VFD		AWS280BDH VFD	
	Circuit 1	Circuit 2	Circuit 1	Circuit 2	Circuit 1	Circuit 2	Circuit 1	Circuit 2
Basic Data								
Unit Capacity @ AHRI tons (kW)	205.2 (721)		224.8 (790)		240.0 (844)		270.6 (951)	
Unit Operating Charge lbs (kg)	160 (73)	160 (73)	180 (82)	180 (82)	180 (82)	180 (82)	200 (91)	200 (91)
Unit Dimensions LxWxH, in. (mm)	268x88x100 (6803x2225x2548)		303x88x100 (7703x2225x2548)		303x88x100 (7703x2225x2548)		339x88x100 (8602x2225x2548)	
Unit Operating Weight, lbs. (kg)	14130 (6410)		15403 (6987)		15953 (7236)		17712 (8034)	
Unit Shipping Weight, lbs (kg)	13587 (6163)		14860 (6740)		15410 (6990)		16845 (7641)	
Weight-Add for Copper Fins	1876 (851)		2084 (945)		2084 (945)		2372 (1076)	
Weight-Add for Louvered Panels	788 (357)		900 (408)		900 (408)		1012 (459)	
Compressors, Screw, Semi-Hermetic								
Nominal Capacity, tons (kW)	105 (369)	105 (369)	105 (369)	125 (439)	125 (439)	125 (439)	125 (439)	150 (528)
Minimum Capacity (% of Full Load)	20		20		20		20	
Oil charge per circuit, gallons (liters)	4.5 (17)	4.5 (17)	4.5 (17)	5.5 (21)	5.5 (21)	5.5 (21)	5.5 (21)	5.5 (21)
Condensers, High Efficiency Fin and Tube Type								
Pumpdown Capacity, lbs (kg)	250 (113)	250 (113)	291 (132)	291 (132)	291 (132)	291 (132)	333 (151)	333 (151)
Coil Inlet Face Area, sq. ft. (sq. m.)	147.7 (13.7)	147.7 (13.7)	172.3 (16.0)	172.3 (16.0)	172.3 (16.0)	172.3 (16.0)	196.9 (18.3)	196.9 (18.3)
Rows Deep/Fins per Inch	3 / 16	3 / 16	3 / 16	3 / 16	3 / 16	3 / 16	3 / 16	3 / 16
Condenser Fans, Direct-Drive Propeller Type								
Number of Fans per Circuit	6	6	7	7	7	7	8	8
Fan Diameter: 31.5 in. (800 mm)								
Fan Motor, hp (kW)	1.4 (1.05)		1.4 (1.05)		1.4 (1.05)		1.4 (1.05)	
Fan & Motor RPM	850		850		850		850	
Fan Tip Speed, fpm (m/s)	6984 (35)		6984 (35)		6984 (35)		6984 (35)	
Airflow, cfm (l/s)	133020 (62778)		155190 (73241)		155190 (73241)		177360 (83704)	
Evaporator, Direct Expansion Shell and Tube								
Shell Diameter-Tube Length, in. (mm)	16x108 / (406x2750)		16x108 / (406x2750)		16x108 / (406x2750)		20x108 / (508x2750)	
Water Volume, gallons (liters)	66 (251)		64 (243)		64 (243)		107 (403)	
Victaulic inlet/outlet connection in. (mm)	6 (168)		6 (168)		6 (168)		8 (219)	
Maximum Water Pressure, psi (kPa)	152 (1048)		152 (1048)		152 (1048)		152 (1048)	
Maximum Refrigerant Pressure, psi (kPa)	325 (2241)		325 (2241)		325 (2241)		325 (2241)	

NOTES: A 20 mesh strainer must be placed in the supply water line just prior to the inlet of the evaporator.
Care must be exercised when welding pipe or flanges to the evaporator to prevent any slag from entering the vessel.

Air-Cooled Chillers

AWS 280B through 330B, High Efficiency, VFD models

Data	AWS300BDH VFD		AWS330BDH VFD		AWS350BDH VFD		AWS390BDH VFD	
	Circuit 1	Circuit 2	Circuit 1	Circuit 2	Circuit 1	Circuit 2	Circuit 1	Circuit 2
Basic Data								
Unit Capacity @ AHRI tons (kW)	287.7 (1012)		326.3 (1147)		347.1 (1220)		377.8 (1328)	
Unit Operating Charge lbs (kg)	210 (95)	210 (95)	260 (118)	260 (118)	265 (120)	265 (120)	270 (122)	320 (145)
Unit Dimensions LxWxH, in. (mm)	339x88x100 (8602x2225x2548)		410x88x100 (10402x2225x2545)		410x88x100 (10402x2225x2545)		461x88x100 (11701x2225x2548)	
Unit Operating Weight, lbs. (kg)	17712 (8034)		19960 (9054)		20652 (9368)		22900 (10387)	
Unit Shipping Weight, lbs (kg)	16845 (7641)		19093 (8661)		19785 (8974)		22033 (9994)	
Weight-Add for Copper Fins	2372 (1076)		2968 (1346)		2968 (1346)		3256 (1477)	
Weight-Add for Louvered Panels	1012 (459)		1236 (561)		1236 (561)		1348 (611)	
Compressors, Screw, Semi-Hermetic								
Nominal Capacity, tons (kW)	150 (528)	150 (528)	150 (528)	175 (615)	175 (615)	175 (615)	175 (615)	205 (721)
Minimum Capacity (% of Full Load)	20		20		20		20	
Oil charge per circuit, gallons (liters)	5.5 (21)	5.5 (21)	5.5 (21)	6 (23)	6 (23)	6 (23)	6 (23)	6 (23)
Condensers, High Efficiency Fin and Tube Type								
Pumpdown Capacity, lbs (kg)	333 (151)	333 (151)	416 (189)	416 (189)	416 (189)	416 (189)	416 (189)	500 (227)
Coil Inlet Face Area, sq. ft. (sq. m.)	196.9 (18.3)	196.9 (18.3)	246.1 (22.8)	246.1 (22.8)	246.1 (22.8)	246.1 (22.8)	246.1 (22.8)	295.3 (27.4)
Rows Deep/Fins per Inch	3 / 16	3 / 16	3 / 16	3 / 16	3 / 16	3 / 16	3 / 16	3 / 16
Condenser Fans, Direct-Drive Propeller Type								
Number of Fans per Circuit	8	8	10	10	10	10	10	12
Fan Diameter: 31.5 in. (800 mm)								
Fan Motor, hp (kW)	1.4 (1.05)		1.4 (1.05)		1.4 (1.05)		1.4 (1.05)	
Fan & Motor RPM	850		850		850		850	
Fan Tip Speed, fpm (m/s)	6984 (35)		6984 (35)		6984 (35)		6984 (35)	
Airflow, cfm (l/s)	177360 (83704)		221700 (104630)		221700 (104630)		243870 (115094)	
Evaporator, Direct Expansion Shell and Tube								
Shell Diameter-Tube Length, in.(mm)	20x108 / (508x2750)		20x108 / (508x2750)		20x108 / (508x2750)		20x108 / (508x2750)	
Water Volume, gallons (liters)	107 (403)		102 (386)		102 (386)		100 (377)	
Victaulic inlet/outlet connection in. (mm)	8 (219)		8 (219)		8 (219)		8 (219)	
Maximum Water Pressure, psi (kPa)	152 (1048)		152 (1048)		152 (1048)		152 (1048)	
Maximum Refrigerant Pressure, psi (kPa)	325 (2241)		325 (2241)		325 (2241)		325 (2241)	

NOTES: A 20 mesh strainer must be placed in the supply water line just prior to the inlet of the evaporator. Care must be exercised when welding pipe or flanges to the evaporator to prevent any slag from entering the vessel.

AWS 350B through 410B, High Efficiency, VFD models

Data	AWS410BDH VFD	
	Circuit 1	Circuit 2
Basic Data		
Unit Capacity @ AHRI tons (kW)	408.7 (1437)	
Unit Operating Charge lbs (kg)	320 (145)	320 (145)
Unit Dimensions LxWxH, in. (mm)	496x88x100 (12604x2225x2545)	
Unit Operating Weight, lbs. (kg)	23705 (10753)	
Unit Shipping Weight, lbs (kg)	22838 (10359)	
Weight-Add for Copper Fins	3553 (1612)	
Weight-Add for Louvered Panels	1460 (662)	
Compressors, Screw, Semi-Hermetic		
Nominal Capacity, tons (kW)	205 (721)	205 (721)
Minimum Capacity (% of Full Load)	20	
Oil charge per circuit, gallons (liters)	6 (23)	6 (23)
Condensers, High Efficiency Fin and Tube Type		
Pumpdown Capacity, lbs (kg)	500 (227)	500 (227)
Coil Inlet Face Area, sq. ft. (sq. m.)	295.3 (27.4)	295.3 (27.4)
Rows Deep/Fins Per Inch	3 / 16	3 / 16
Condenser Fans, Direct-Drive Propeller Type		
Number of Fans per Circuit	12	12
Fan Diameter: 31.5 in. (800 mm)		
Fan Motor, hp (kW)	1.4 (1.05)	
Fan & Motor RPM	850	
Fan Tip Speed, fpm (m/s)	6984 (35)	
Airflow, cfm (l/s)	266040 (125556)	
Evaporator, Direct Expansion Shell and Tube		
Shell Diameter-Tube Length, in. (mm)	20x108 / (508x2750)	
Water Volume, gallons (liters)	100 (377)	
Victaulic inlet/outlet connection in. (mm)	8 (219)	
Maximum Water Pressure, psi (kPa)	152 (1048)	
Maximum Refrigerant Pressure, psi (kPa)	325 (2241)	

NOTES: A 20 mesh strainer must be placed in the supply water line just prior to the inlet of the evaporator. Care must be exercised when welding pipe or flanges to the evaporator to prevent any slag from entering the vessel.

Air-Cooled Chillers

AWS 450B through 500B, High Efficiency, VFD models

Data	AWS450BTH VFD			AWS475BTH VFD			AWS500BTH VFD		
	Circuit 1	Circuit 2	Circuit 3	Circuit 1	Circuit 2	Circuit 3	Circuit 1	Circuit 2	Circuit 3
Basic Data									
Unit Capacity @ AHRI tons (kW)	445.2 (1565)			467.7 (1644)			497.8 (1750)		
Unit Operating Charge lbs (kg)	210 (95)	210 (95)	220 (100)	210 (95)	210 (95)	280 (187)	265 (120)	265 (120)	220 (100)
Unit Dimensions LxWxH, in. (mm)	496x88x100 (12605x2225x2548)			532x88x100 (13504x2225x2545)			567x88x100 (14405x2225x2548)		
Unit Operating Weight, lbs. (kg)	27152 (12316)			28300 (12837)			30117 (13661)		
Unit Shipping Weight, lbs (kg)	25753 (11682)			26901 (12202)			28718 (13026)		
Weight-Add for Copper Fins	3553 (1612)			3870 (1755)			4168 (1891)		
Weight-Add for Louvered Panels	1460 (662)			1572 (713)			1684 (764)		
Compressors, Screw, Semi-Hermetic									
Nominal Capacity, tons (kW)	150 (528)	150 (528)	150 (528)	150 (528)	150 (528)	175 (615)	175 (615)	175 (615)	150 (528)
Minimum Capacity (% of Full Load)	13			13			13		
Oil charge per circuit, gallons (liters)	5.5 (21)	5.5 (21)	5.5 (21)	5.5 (21)	5.5 (21)	6 (23)	6 (23)	6 (23)	5.5 (21)
Condensers, High Efficiency Fin and Tube Type									
Pumpdown Capacity, lbs (kg)	333 (151)	333 (151)	333 (151)	333 (151)	333 (151)	416 (189)	416 (189)	416 (189)	333 (151)
Coil Inlet Face Area, sq. ft. (sq. m.)	196.9 (18.3)	196.9 (18.3)	196.9 (18.3)	196.9 (18.3)	196.9 (18.3)	246.1 (22.8)	246.1 (22.8)	246.1 (22.8)	196.9 (18.3)
Rows Deep/Fins per Inch	3 / 16	3 / 16	3 / 16	3 / 16	3 / 16	3 / 16	3 / 16	3 / 16	3 / 16
Condenser Fans, Direct-Drive Propeller Type									
Number of Fans per Circuit Fan Diameter: 31.5 in. (800 mm)	8	8	8	8	8	10	10	10	8
Fan Motor, hp (kW)	1.4 (1.05)			1.4 (1.05)			1.4 (1.05)		
Fan & Motor RPM	850			850			850		
Fan Tip Speed, fpm (m/s)	6984 (35)			6984 (35)			6984 (35)		
Airflow, cfm (l/s)	266040 (125556)			288210 (136019)			310380 (146482)		
Evaporator, Direct Expansion Shell and Tube									
Shell Diameter-Tube Length, in. (mm)	26x130 / (660x3300)			26x130 / (660x3300)			26x130 / (660x3300)		
Water Volume, gallons (liters)	225 (850)			220 (831)			220 (831)		
Victaulic inlet/outlet connection in. (mm)	10 (273)			10 (273)			10 (273)		
Maximum Water Pressure, psi (kPa)	152 (1048)			152 (1048)			152 (1048)		
Maximum Refrigerant Pressure, psi (kPa)	325 (2241)			325 (2241)			325 (2241)		

NOTES: A 20 mesh strainer must be placed in the supply water line just prior to the inlet of the evaporator.
Care must be exercised when welding pipe or flanges to the evaporator to prevent any slag from entering the vessel.

AWS 530B, High Efficiency, VFD models

Data	AWS530BTH VFD		
	Circuit 1	Circuit 2	Circuit 3
Basic Data			
Unit Capacity @ AHRI tons (kW)	524.8 (1845)		
Unit Operating Charge lbs (kg)	265 (120)	265 (120)	280 (187)
Unit Dimensions LxWxH, in. (mm)	603x88x100 (15304x2225x2545)		
Unit Operating Weight, lbs. (kg)	31446 (14264)		
Unit Shipping Weight, lbs (kg)	30047 (13629)		
Weight-Add for Copper Fins	4466 (2026)		
Weight-Add for Louvered Panels	1796 (815)		
Compressors, Screw, Semi-Hermetic			
Nominal Capacity, tons (kW)	175 (615)	175 (615)	175 (615)
Minimum Capacity (% of Full Load)	13		
Oil charge per circuit, gallons (liters)	6 (23)	6 (23)	6 (23)
Condensers, High Efficiency Fin and Tube Type			
Pumpdown Capacity, lbs (kg)	416 (189)	416 (189)	416 (189)
Coil Inlet Face Area, sq. ft. (sq. m.)	246.1 (22.8)	246.1 (22.8)	246.1 (22.8)
Rows Deep/Fins Per Inch	3 / 16	3 / 16	3 / 16
Condenser Fans, Direct-Drive Propeller Type			
Number of Fans per Circuit Fan Diameter: 31.5 in. (800 mm)	10	10	10
Fan Motor, hp (kW)	1.4 (1.05)		
Fan & Motor RPM	850		
Fan Tip Speed, fpm (m/s)	6984 (35)		
Airflow, cfm (l/s)	332550 (156945)		
Evaporator, Direct Expansion Shell and Tube			
Shell Diameter-Tube Length, in. (mm)	26x130 / (660x3300)		
Water Volume, gallons (liters)	220 (831)		
Victaulic inlet/outlet connection in. (mm)	10 (273)		
Maximum Water Pressure, psi (kPa)	152 (1048)		
Maximum Refrigerant Pressure, psi (kPa)	325 (2241)		

NOTES: A 20 mesh strainer must be placed in the supply water line just prior to the inlet of the evaporator.
Care must be exercised when welding pipe or flanges to the evaporator to prevent any slag from entering the vessel.

Air-Cooled Chillers

Physical Data—Pathfinder® Premium Efficiency (VFD)

AWS 240B through 310B, Premium Efficiency, VFD models

Data	AWS240BDP VFD		AWS265BDP VFD		AWS290BDP VFD		AWS310BDP VFD	
	Circuit 1	Circuit 2	Circuit 1	Circuit 2	Circuit 1	Circuit 2	Circuit 1	Circuit 2
Basic Data								
Unit Capacity @ AHRI tons (kW)	232.7 (818)		256.3 (901)		277.6 (976)		303.8 (1068)	
Unit Operating Charge lbs (kg)	200 (91)	200 (91)	225 (102)	225 (102)	(235) (107)	(235) (107)	250 (113)	250 (113)
Unit Dimensions LxWxH, in. (mm)	339x88x100 (8602x2225x2548)		374x88x100 (9504x2225x2545)		374x88x100 (9504x2225x2545)		410x88x100 (10402x2225x2545)	
Unit Operating Weight, lbs. (kg)	17427 (7905)		18676 (8471)		20612 (9350)		21534 (9768)	
Unit Shipping Weight, lbs (kg)	16175 (7337)		17424 (7904)		18959 (8600)		19881 (9018)	
Weight-Add for Copper Fins	2372 (1076)		2679 (1215)		2679 (1215)		2968 (1346)	
Weight-Add for Louvered Panels	1012 (459)		1124 (510)		1124 (510)		1236 (561)	
Compressors, Screw, Semi-Hermetic								
Nominal Capacity, tons (kW)	105 (369)	105 (369)	105 (369)	125 (439)	125 (439)	125 (439)	125 (439)	150 (528)
Minimum Capacity (% of Full Load)	20		20		20		20	
Oil charge per circuit, gallons (liters)	4.5 (17)	4.5 (17)	4.5 (17)	5.5 (21)	5.5 (21)	5.5 (21)	5.5 (21)	5.5 (21)
Condensers, High Efficiency Fin and Tube Type								
Pumpdown Capacity, lbs (kg)	333 (151)	333 (151)	375 (170)	375 (170)	375 (170)	375 (170)	416 (189)	416 (189)
Coil Inlet Face Area, sq. ft. (sq. m.)	196.9 (18.3)	196.9 (18.3)	221.5 (20.6)	221.5 (20.6)	221.5 (20.6)	221.5 (20.6)	246.1 (22.8)	246.1 (22.8)
Rows Deep/Fins per Inch	3 / 16	3 / 16	3 / 16	3 / 16	3 / 16	3 / 16	3 / 16	3 / 16
Condenser Fans, Direct-Drive Propeller Type								
Number of Fans per Circuit	8	8	9	9	9	9	10	10
Fan Diameter: 31.5 in. (800 mm)								
Fan Motor, hp (kW)	1.4 (1.05)		1.4 (1.05)		1.4 (1.05)		1.4 (1.05)	
Fan & Motor RPM	850		850		850		850	
Fan Tip Speed, fpm (m/s)	6984 (35)		6984 (35)		6984 (35)		6984 (35)	
Airflow, cfm (l/s)	177360 (83704)		199530 (94167)		199530 (94167)		221700 (104630)	
Evaporator, Direct Expansion Shell and Tube								
Shell Diameter-Tube Length, in. (mm)	20x154 / (508x3900)		20x154 / (508x3900)		26x154 / (660x3900)		26x154 / (660x3900)	
Water Volume, gallons (liters)	158 (599)		158 (599)		276 (1043)		276 (1043)	
Victaulic inlet/outlet connection in. (mm)	8 (2199)		8 (219)		10 (273)		10 (273)	
Maximum Water Pressure, psi (kPa)	152 (1048)		152 (1048)		152 (1048)		152 (1048)	
Maximum Refrigerant Pressure, psi (kPa)	325 (2241)		325 (2241)		325 (2241)		325 (2241)	

NOTES: A 20 mesh strainer must be placed in the supply water line just prior to the inlet of the evaporator.
Care must be exercised when welding pipe or flanges to the evaporator to prevent any slag from entering the vessel.

AWS 330B through 400B, Premium Efficiency, VFD models

Data	AWS330BDP VFD		AWS365BDP VFD		AWS400BDP VFD	
	Circuit 1	Circuit 2	Circuit 1	Circuit 2	Circuit 1	Circuit 2
Basic Data						
Unit Capacity @ AHRI tons (kW)	324.7 (1142)		354.8 (1247)		385.4 (1355)	
Unit Operating Charge lbs (kg)	260 (118)	260 (118)	260 (118)	300 (136)	310 (141)	310 (141)
Unit Dimensions LxWxH, in. (mm)	410x88x100 (10402x2225x2545)		461x88x100 (11701x2225x2548)		496x88x100 (12604x2225x2545)	
Unit Operating Weight, lbs. (kg)	22485 (10199)		24441 (11086)		25881 (11740)	
Unit Shipping Weight, lbs (kg)	21534 (9768)		22788 (10337)		24228 (10990)	
Weight-Add for Copper Fins	2968 (1346)		3256 (1477)		3553 (1612)	
Weight-Add for Louvered Panels	1236 (561)		1348 (611)		1460 (662)	
Compressors, Screw, Semi-Hermetic						
Nominal Capacity, tons (kW)	150 (528)	150 (528)	150 (528)	175 (615)	175 (615)	175 (615)
Minimum Capacity (% of Full Load)	20		20		20	
Oil charge per circuit, gallons (liters)	5.5 (21)	5.5 (21)	5.5 (21)	6 (23)	6 (23)	6 (23)
Condensers, High Efficiency Fin and Tube Type						
Pumpdown Capacity, lbs (kg)	416 (189)	416 (189)	416 (189)	500 (227)	500 (227)	500 (227)
Coil Inlet Face Area, sq. ft. (sq. m.)	246.1 (22.8)	246.1 (22.8)	246.1 (22.8)	295.3 (27.4)	295.3 (27.4)	295.3 (27.4)
Rows Deep/Fins per Inch	3 / 16	3 / 16	3 / 16	3 / 16	3 / 16	3 / 16
Condenser Fans, Direct-Drive Propeller Type						
Number of Fans per Circuit	10	10	10	12	12	12
Fan Diameter: 31.5 in. (800 mm)						
Fan Motor, hp (kW)	1.4 (1.05)		1.4 (1.05)		1.4 (1.05)	
Fan & Motor RPM	850		850		850	
Fan Tip Speed, fpm (m/s)	6984 (35)		6984 (35)		6984 (35)	
Airflow, cfm (l/s)	221700 (104630)		243870 (115093)		266040 (125556)	
Evaporator, Direct Expansion Shell and Tube						
Shell Diameter-Tube Length, in. (mm)	26x154 / (660x3900)		26x154 / (660x3900)		26x154 / (660x3900)	
Water Volume, gallons (liters)	259 (979)		259 (979)		259 (979)	
Victaulic inlet/outlet connection in. (mm)	10 (273)		10 (273)		10 (273)	
Maximum Water Pressure, psi (kPa)	152 (1048)		152 (1048)		152 (1048)	
Maximum Refrigerant Pressure, psi (kPa)	325 (2241)		325 (2241)		325 (2241)	

NOTES: A 20 mesh strainer must be placed in the supply water line just prior to the inlet of the evaporator.
Care must be exercised when welding pipe or flanges to the evaporator to prevent any slag from entering the vessel.

Air-Cooled Chillers

Physical Data—Pathfinder® with Remote Evaporator, Standard Efficiency

AWS 190B through 250B, Remote Evaporator, Standard Efficiency

Data	AWS190BDS Remote Evap		AWS210BDS Remote Evap		AWS225BDS Remote Evap		AWS250BDS Remote Evap	
	Circuit 1	Circuit 2	Circuit 1	Circuit 2	Circuit 1	Circuit 2	Circuit 1	Circuit 2
Basic Data								
Unit Capacity @ AHRJ tons (kW)	180.1 (633)		201.3 (708)		216.3 (760)		235.8 (829)	
Unit Operating Charge lbs (kg)	145 (66)	145 (66)	165 (75)	165 (75)	165 (75)	165 (75)	185 (84)	185 (84)
Unit Dimensions LxWxH, in. (mm)	245x88x100 (6220x2225x2548)		245x88x100 (6220x2225x2548)		245x88x100 (6220x2225x2548)		280x88x100 (7121x2225x2548)	
Unit Operating Weight, lbs. (kg)	11515 (5223)		12244 (5554)		12746 (5782)		13666 (6199)	
Unit Shipping Weight, lbs (kg)	11515 (5223)		12244 (5554)		12746 (5782)		13666 (6199)	
Weight-Add for Copper Fins, lbs (kg)	1786 (810)		1786 (810)		1786 (810)		2084 (945)	
Weight-Add for Louvered Panels, lbs (kg)	676 (307)		788 (357)		788 (357)		900 (408)	
Weight-Add for Sound Enclosures, lbs (kg)	477 (216)		477 (216)		477 (216)		477 (216)	
Weight-Add for PFCC option, lbs (kg)	160 (73)		160 (73)		160 (73)		160 (73)	
Compressors, Screw, Semi-Hermetic								
Nominal Capacity, tons (kW)	95 (334)	95 (334)	95 (334)	115 (404)	115 (404)	115 (404)	115 (404)	135 (475)
Minimum Capacity (% of Full Load)	15		15		15		15	
Oil charge per circuit, gallons (liters)	4.5 (17)	4.5 (17)	4.5 (17)	5.5 (21)	5.5 (21)	5.5 (21)	5.5 (21)	5.5 (21)
Condensers, High Efficiency Fin and Tube Type								
Pumpdown Capacity, lbs (kg)	208 (94)	208 (94)	250 (113)	250 (113)	250 (113)	250 (113)	291 (132)	291 (132)
Coil Inlet Face Area, sq. ft. (sq. m.)	123.1 (11.4)	123.1 (11.4)	147.7 (13.7)	147.7 (13.7)	147.7 (13.7)	147.7 (13.7)	172.3 (16.0)	172.3 (16.0)
Rows Deep/Fins per Inch	3 / 16	3 / 16	3 / 16	3 / 16	3 / 16	3 / 16	3 / 16	3 / 16
Condenser Fans, Direct-Drive Propeller Type								
Number of Fans per Circuit Fan Diameter: 31.5 in. (800 mm)	5	5	6	6	6	6	7	7
Fan Motor, hp (kW)	1.4 (1.05)		1.4 (1.05)		1.4 (1.05)		1.4 (1.05)	
Fan & Motor RPM	850		850		850		850	
Fan Tip Speed, fpm (m/s)	6984 (35)		6984 (35)		6984 (35)		6984 (35)	
Airflow, cfm (l/s)	110850 (52315)		133020 (62778)		133020 (62778)		155190 (73241)	
Remote Evaporator, Direct Expansion Shell and Tube								
Shell Diameter-Tube Length, in. (mm)	16x406 (406x2750)		16x108 (406x2750)		16x108 (406x2750)		16x108 / (406x2750)	
Water Volume, gallons (liters)	68 (258)		66 (251)		66 (251)		64 (243)	
Victaulic inlet/outlet connection in. (mm)	6 (168)		6 (168)		6 (168)		6 (168)	
Maximum Water Pressure, psi (kPa)	152 (1048)		152 (1048)		152 (1048)		152 (1048)	
Maximum Refrigerant Pressure, psi (kPa)	325 (2241)		325 (2241)		325 (2241)		325 (2241)	

NOTES: A 20 mesh strainer must be placed in the supply water line just prior to the inlet of the evaporator.
Care must be exercised when welding pipe or flanges to the evaporator to prevent any slag from entering the vessel.

AWS 260BDS through 350BDS, Remote Evaporator, Standard Efficiency

Data	AWS260BDS Remote Evap		AWS290BDS Remote Evap		AWS310BDS Remote Evap		AWS350BDS Remote Evap	
	Circuit 1	Circuit 2	Circuit 1	Circuit 2	Circuit 1	Circuit 2	Circuit 1	Circuit 2
Basic Data								
Unit Capacity @ AHRJ tons (kW)	250.5 (881)		282.9 (995)		300.4 (1056)		340.6 (1197)	
Unit Operating Charge lbs (kg)	185 (84)	185 (84)	210 (95)	210 (95)	215 (98)	215 (98)	265 (120)	265 (120)
Unit Dimensions LxWxH, in. (mm)	280x88x100 (7121x2225x2548)		316x88x100 (8022x2225x2548)		316x88x100 (8026x2225x2548)		387x88x100 (9823x2225x2548)	
Unit Operating Weight, lbs. (kg)	13666 (6199)		15158 (6876)		15854 (7191)		17550 (7961)	
Unit Shipping Weight, lbs (kg)	13666 (6199)		15158 (6876)		15854 (7191)		17550 (7961)	
Weight-Add for Copper Fins, lbs (kg)	2084 (945)		2372 (1076)		2372 (1076)		2968 (1346)	
Weight-Add for Louvered Panels, lbs (kg)	900 (408)		1012 (459)		1012 (459)		1236 (561)	
Weight-Add for Sound Enclosures, lbs (kg)	477 (216)		477 (216)		477 (216)		477 (216)	
Weight-Add for PFCC option, lbs (kg)	160 (73)		160 (73)		160 (73)		160 (73)	
Compressors, Screw, Semi-Hermetic								
Nominal Capacity, tons (kW)	135 (475)	135 (475)	135 (475)	155 (545)	155 (545)	155 (545)	155 (545)	185 (650)
Minimum Capacity (% of Full Load)	15		15		15		15	
Oil charge per circuit, gallons (liters)	5.5 (21)	5.5 (21)	5.5 (21)	6 (23)	6 (23)	6 (23)	6 (23)	6 (23)
Condensers, High Efficiency Fin and Tube Type								
Pumpdown Capacity, lbs (kg)	291 (132)	291 (132)	333 (151)	333 (151)	333 (151)	333 (151)	416 (189)	416 (189)
Coil Inlet Face Area, sq. ft. (sq. m.)	172.3 (16.0)	172.3 (16.0)	196.9 (18.3)	196.9 (18.3)	196.9 (18.3)	196.9 (18.3)	246.1 (22.8)	246.1 (22.8)
Rows Deep/Fins per Inch	3 / 16	3 / 16	3 / 16	3 / 16	3 / 16	3 / 16	3 / 16	3 / 16
Condenser Fans, Direct-Drive Propeller Type								
Number of Fans per Circuit Fan Diameter: 31.5 in. (800 mm)	7	7	8	8	8	8	10	10
Fan Motor, hp (kW)	1.4 (1.05)		1.4 (1.05)		1.4 (1.05)		1.4 (1.05)	
Fan & Motor RPM	850		850		850		850	
Fan Tip Speed, fpm (m/s)	6984 (35)		6984 (35)		6984 (35)		6984 (35)	
Airflow, cfm (l/s)	155190 (73241)		177360 (83704)		177360 (83704)		221700 (104630)	
Remote Evaporator, Direct Expansion Shell and Tube								
Shell Diameter-Tube Length, in. (mm)	16x108 / (406x2750)		20x108 / (508x2750)		20x108 / (508x2750)		20x108 / (508x2750)	
Water Volume, gallons (liters)	64 (243)		107 (403)		107 (403)		102 (386)	
Victaulic inlet/outlet connection in. (mm)	6 (168)		8 (219)		8 (219)		8 (219)	
Maximum Water Pressure, psi (kPa)	152 (1048)		152 (1048)		152 (1048)		152 (1048)	
Maximum Refrigerant Pressure, psi (kPa)	325 (2241)		325 (2241)		325 (2241)		325 (2241)	

NOTES: A 20 mesh strainer must be placed in the supply water line just prior to the inlet of the evaporator.
Care must be exercised when welding pipe or flanges to the evaporator to prevent any slag from entering the vessel.

Air-Cooled Chillers

Air-Cooled Chillers

AWS 375B, Remote Evaporator, Standard Efficiency

Data	AWS375BDS Remote Evap	
	Circuit 1	Circuit 2
Basic Data		
Unit Capacity @ AHRI tons (kW)	361.4 (1271)	
Unit Operating Charge lbs (kg)	265 (120)	265 (120)
Unit Dimensions LxWxH, in. (mm)	387x88x100 (9823x2225x2548)	
Unit Operating Weight, lbs. (kg)	17550 (7961)	
Unit Shipping Weight, lbs (kg)	17550 (7961)	
Weight-Add for Copper Fins, lbs (kg)	2968 (1346)	
Weight-Add for Louvered Panels, lbs (kg)	1236 (561)	
Weight-Add for Sound Enclosures, lbs (kg)	477 (216)	
Weight-Add for PFCC option, lbs (kg)	160 (73)	
Compressors, Screw, Semi-Hermetic		
Nominal Capacity, tons (kW)	185 (650)	185 (650)
Minimum Capacity (% of Full Load)	15	
Oil charge per circuit, gallons (liters)	6 (23)	6 (23)
Condensers, High Efficiency Fin and Tube Type		
Pumpdown Capacity, lbs (kg)	416 (189)	416 (189)
Coil Inlet Face Area, sq. ft. (sq. m.)	246.1 (22.8)	246.1 (22.8)
Rows Deep/Fins per Inch	3 / 16	3 / 16
Condenser Fans, Direct-Drive Propeller Type		
Number of Fans per Circuit	10	10
Fan Diameter: 31.5 in. (800 mm)		
Fan Motor, hp (kW)	1.4 (1.05)	
Fan & Motor RPM	850	
Fan Tip Speed, fpm (m/s)	6984 (35)	
Airflow, cfm (l/s)	221700 (104630)	
REMOTE EVAPORATOR, DIRECT EXPANSION SHELL AND TUBE		
Shell Diameter-Tube Length, in. (mm)	20x108 / (508x2750)	
Water Volume, gallons (liters)	102 (386)	
Victaulic inlet/outlet connection in. (mm)	8 (219)	
Maximum Water Pressure, psi (kPa)	152 (1048)	
Maximum Refrigerant Pressure, psi (kPa)	325 (2241)	

NOTES: A 20 mesh strainer must be placed in the supply water line just prior to the inlet of the evaporator. Care must be exercised when welding pipe or flanges to the evaporator to prevent any slag from entering the vessel.

Physical Data—Pathfinder® with Remote Evaporator, High Efficiency AWS 210BDH through 280BDH, Remote Evaporator, High Efficiency

Data	AWS210BDH Remote Evap		AWS230BDH Remote Evap		AWS250BDH Remote Evap		AWS280BDH Remote Evap	
	Circuit 1	Circuit 2	Circuit 1	Circuit 2	Circuit 1	Circuit 2	Circuit 1	Circuit 2
Basic Data								
Unit Capacity @ AHRI tons (kW)	205.7 (723)		225.2 (792)		240.6 (846)		271.9 (956)	
Unit Operating Charge lbs (kg)	160 (73)	160 (73)	180 (82)	180 (82)	180 (82)	180 (82)	230 (104)	250 (113)
Unit Dimensions LxWxH, in. (mm)	245x88x100 (6220x2225x2548)		280x88x100 (7121x2225x2548)		280x88x100 (7121x2225x2548)		316x88x100 (8022x2225x2548)	
Unit Operating Weight, lbs. (kg)	12229 (5547)		13754 (6239)		14417 (6540)		15230 (6908)	
Unit Shipping Weight, lbs (kg)	12229 (5547)		13754 (6239)		14417 (6540)		15230 (6908)	
Weight-Add for Copper Fins, lbs (kg)	1876 (851)		2084 (945)		2084 (945)		2372 (1076)	
Weight-Add for Louvered Panels, lbs (kg)	788 (357)		900 (408)		900 (408)		1012 (459)	
Weight-Add for Sound Enclosures, lbs (kg)	477 (216)		477 (216)		477 (216)		477 (216)	
Weight-Add for PFCC option, lbs (kg)	160 (73)		160 (73)		160 (73)		160 (73)	
Compressors, Screw, Semi-Hermetic								
Nominal Capacity, tons (kW)	105 (369)	105 (369)	105 (369)	125 (439)	125 (439)	125 (439)	125 (439)	150 (528)
Minimum Capacity (% of Full Load)	15		15		15		15	
Oil charge per circuit, gallons (liters)	4.5 (17)	4.5 (17)	4.5 (17)	5.5 (21)	5.5 (21)	5.5 (21)	5.5 (21)	5.5 (21)
Condensers, High Efficiency Fin and Tube Type								
Pumpdown Capacity, lbs (kg)	250 (113)	250 (113)	291 (132)	291 (132)	291 (132)	291 (132)	333 (151)	333 (151)
Coil Inlet Face Area, sq. ft. (sq. m.)	147.7 (13.7)	147.7 (13.7)	172.3 (16.0)	172.3 (16.0)	172.3 (16.0)	172.3 (16.0)	196.9 (18.3)	196.9 (18.3)
Rows Deep/Fins per Inch	3 / 16	3 / 16	3 / 16	3 / 16	3 / 16	3 / 16	3 / 16	3 / 16
Condenser Fans, Direct-Drive Propeller Type								
Number of Fans per Circuit	6	6	7	7	7	7	8	8
Fan Diameter: 31.5 in. (800 mm)								
Fan Motor, hp (kW)	1.4 (1.05)		1.4 (1.05)		1.4 (1.05)		1.4 (1.05)	
Fan & Motor RPM	850		850		850		850	
Fan Tip Speed, fpm (m/s)	6984 (35)		6984 (35)		6984 (35)		6984 (35)	
Airflow, cfm (l/s)	133020 (62778)		155190 (73241)		155190 (73241)		177360 (83704)	
Remote Evaporator, Direct Expansion Shell and Tube								
Shell Diameter-Tube Length, in. (mm)	16x108 / (406x2750)		16x108 / (406x2750)		16x108 / (406x2750)		20x108 / (508x2750)	
Water Volume, gallons (liters)	66 (251)		64 (243)		64 (243)		107 (403)	
Victaulic inlet/outlet connection in. (mm)	6 (168)		6 (168)		6 (168)		8 (219)	
Maximum Water Pressure, psi (kPa)	152 (1048)		152 (1048)		152 (1048)		152 (1048)	
Maximum Refrigerant Pressure, psi (kPa)	325 (2241)		325 (2241)		325 (2241)		325 (2241)	

NOTES: A 20 mesh strainer must be placed in the supply water line just prior to the inlet of the evaporator. Care must be exercised when welding pipe or flanges to the evaporator to prevent any slag from entering the vessel.

Air-Cooled Chillers

AWS 300B through 390B, Remote Evaporator, High Efficiency

Data	AWS300BDH Remote Evap		AWS330BDH Remote Evap		AWS350BDH Remote Evap		AWS390BDH Remote Evap	
	Circuit 1	Circuit 2	Circuit 1	Circuit 2	Circuit 1	Circuit 2	Circuit 1	Circuit 2
Basic Data								
Unit Capacity @ AHRI tons (kW)	288.7 (1015)		327.3 (1151)		348.1 (1224)		378.7 (1332)	
Unit Operating Charge lbs (kg)	250 (113)	250 (113)	260 (118)	285 (129)	285 (129)	285 (129)	285 (129)	331 (150)
Unit Dimensions LxWxH, in. (mm)	316x88x100 (8022x2225x2548)		387x88x100 (9823x2225x2548)		387x88x100 (9823x2225x2548)		438x88x100 (11123x2225x2548)	
Unit Operating Weight, lbs. (kg)	15230 (6908)		17576 (7972)		18282 (8293)		19750 (8959)	
Unit Shipping Weight, lbs (kg)	15230 (6908)		17576 (7972)		18282 (8293)		19750 (8959)	
Weight-Add for Copper Fins, lbs (kg)	2372 (1076)		2968 (1346)		2968 (1346)		3256 (1477)	
Weight-Add for Louvered Panels, lbs (kg)	1012 (459)		1236 (561)		1236 (561)		1348 (611)	
Weight-Add for Sound Enclosures, lbs (kg)	477 (216)		477 (216)		477 (216)		477 (216)	
Weight-Add for PFCC option, lbs (kg)	160 (73)		160 (73)		160 (73)		160 (73)	
Compressors, Screw, Semi-Hermetic								
Nominal Capacity, tons (kW)	150 (528)	150 (528)	150 (528)	175 (615)	175 (615)	175 (615)	175 (615)	205 (721)
Minimum Capacity (% of Full Load)	15		15		15		15	
Oil charge per circuit, gallons (liters)	5.5 (21)	5.5 (21)	5.5 (21)	6 (23)	6 (23)	6 (23)	6 (23)	6 (23)
Condensers, High Efficiency Fin and Tube Type								
Pumpdown Capacity, lbs (kg)	333 (151)	333 (151)	416 (189)	416 (189)	416 (189)	416 (189)	416 (189)	500 (227)
Coil Inlet Face Area, sq. ft. (sq. m.)	196.9 (18.3)	196.9 (18.3)	246.1 (22.8)	246.1 (22.8)	246.1 (22.8)	246.1 (22.8)	246.1 (22.8)	295.3 (27.4)
Rows Deep/Fins per Inch	3 / 16	3 / 16	3 / 16	3 / 16	3 / 16	3 / 16	3 / 16	3 / 16
Condenser Fans, Direct-Drive Propeller Type								
Number of Fans per Circuit Fan Diameter: 31.5 in. (800 mm)	8	8	10	10	10	10	10	12
Fan Motor, hp (kW)	1.4 (1.05)		1.4 (1.05)		1.4 (1.05)		1.4 (1.05)	
Fan & Motor RPM	850		850		850		850	
Fan Tip Speed, fpm (m/s)	6984 (35)		6984 (35)		6984 (35)		6984 (35)	
Airflow, cfm (l/s)	177360 (83704)		221700 (104630)		221700 (104630)		243870 (115094)	
Remote Evaporator, Direct Expansion Shell and Tube								
Shell Diameter-Tube Length, in. (mm)	20x108 / (508x2750)		20x108 / (508x2750)		20x108 / (508x2750)		20x108 / (508x2750)	
Water Volume, gallons (liters)	107 (403)		102 (386)		102 (386)		100 (377)	
Victaulic inlet/outlet connection in. (mm)	8 (219)		8 (219)		8 (219)		8 (219)	
Maximum Water Pressure, psi (kPa)	152 (1048)		152 (1048)		152 (1048)		152 (1048)	
Maximum Refrigerant Pressure, psi (kPa)	325 (2241)		325 (2241)		325 (2241)		325 (2241)	

NOTES: A 20 mesh strainer must be placed in the supply water line just prior to the inlet of the evaporator.
Care must be exercised when welding pipe or flanges to the evaporator to prevent any slag from entering the vessel.

AWS 410BDH, Remote Evaporator, High Efficiency

Data	AWS410BDH Remote Evap	
	Circuit 1	Circuit 2
Basic Data		
Unit Capacity @ AHRI tons (kW)	409.8 (1441)	
Unit Operating Charge lbs (kg)	331 (150)	331 (150)
Unit Dimensions LxWxH, in. (mm)	473x88x101 (12024x2225x2548)	
Unit Operating Weight, lbs. (kg)	20279 (9335)	
Unit Shipping Weight, lbs (kg)	20279 (9335)	
Weight-Add for Copper Fins, lbs (kg)	3553 (1612)	
Weight-Add for Louvered Panels, lbs (kg)	1460 (662)	
Weight-Add for Sound Enclosures, lbs (kg)	477 (216)	
Weight-Add for PFCC option, lbs (kg)	160 (73)	
Compressors, Screw, Semi-Hermetic		
Nominal Capacity, tons (kW)	205 (721)	205 (721)
Minimum Capacity (% of Full Load)	15	
Oil charge per circuit, gallons (liters)	6 (23)	6 (23)
Condensers, High Efficiency Fin and Tube Type		
Pumpdown Capacity, lbs (kg)	500 (227)	500 (227)
Coil Inlet Face Area, sq. ft. (sq. m.)	295.3 (27.4)	295.3 (27.4)
Rows Deep/Fins per Inch	3 / 16	3 / 16
Condenser Fans, Direct-Drive Propeller Type		
Number of Fans per Circuit Fan Diameter: 31.5 in. (800 mm)	12	12
Fan Motor, hp (kW)	1.4 (1.05)	
Fan & Motor RPM	850	
Fan Tip Speed, fpm (m/s)	6984 (35)	
Airflow, cfm (l/s)	266040 (125556)	
REMOTE EVAPORATOR, DIRECT EXPANSION SHELL AND TUBE		
Shell Diameter-Tube Length, in. (mm)	20x108 / (508x2750)	
Water Volume, gallons (liters)	100 (377)	
Victaulic inlet/outlet connection in. (mm)	8 (219)	
Maximum Water Pressure, psi (kPa)	152 (1048)	
Maximum Refrigerant Pressure, psi (kPa)	325 (2241)	

NOTES: A 20 mesh strainer must be placed in the supply water line just prior to the inlet of the evaporator. Care must be exercised when welding pipe or flanges to the evaporator to prevent any slag from entering the vessel.

Air-Cooled Chillers

AWS 450B through 500B, Remote Evaporator, High Efficiency

Data	AWS450BTH Remote Evap			AWS475BTH Remote Evap			AWS500BTH Remote Evap		
	Circuit 1	Circuit 2	Circuit 3	Circuit 1	Circuit 2	Circuit 3	CIRCUIT 1	CIRCUIT 2	CIRCUIT 3
BASIC DATA									
Unit Capacity @ AHRI tons (kW)	446.3 (1569)			470.3 (1654)			499.4 (1756)		
Unit Operating Charge lbs (kg)	250 (113)	250 (113)	250 (113)	250 (113)	250 (113)	295 (134)	295 (134)	295 (134)	250 (113)
Unit Dimensions LxWxH, in. (mm)	473x88x100 (12024x2225x2548)			509x88x100 (12921x2225x2548)			544x88x100 (13823x2225x2548)		
Unit Operating Weight, lbs. (kg)	22135 (10040)			23608 (10709)			25528 (11579)		
Unit Shipping Weight, lbs (kg)	22135 (10040)			23608 (10709)			25528 (11579)		
Weight-Add for Copper Fins, lbs (kg)	3553 (1612)			3870 (1755)			4168 (1891)		
Weight-Add for Louvered Panels, lbs (kg)	1460 (662)			1572 (713)			1684 (764)		
Weight-Add for Sound Enclosures, lbs (kg)	776 (352)			776 (352)			776 (352)		
Weight-Add for PFCC option, lbs (kg)	120 (55)			120 (55)			120 (55)		
Compressors, Screw, Semi-Hermetic									
Nominal Capacity, tons (kW)	150 (528)	150 (528)	150 (528)	150 (528)	150 (528)	175 (615)	175 (615)	175 (615)	150 (528)
Minimum Capacity (% of Full Load)	8			8			8		
Oil charge per circuit, gallons (liters)	5.5 (21)	5.5 (21)	5.5 (21)	5.5 (21)	5.5 (21)	6 (23)	6 (23)	6 (23)	5.5 (21)
Condensers, High Efficiency Fin and Tube Type									
Pumpdown Capacity, lbs (kg)	333 (151)	333 (151)	333 (151)	333 (151)	333 (151)	416 (189)	416 (189)	416 (189)	333 (151)
Coil Inlet Face Area, sq. ft. (sq. m.)	196.9 (18.3)	196.9 (18.3)	196.9 (18.3)	196.9 (18.3)	196.9 (18.3)	246.1 (22.8)	246.1 (22.8)	246.1 (22.8)	196.9 (18.3)
Rows Deep/Fins per Inch	3 / 16	3 / 16	3 / 16	3 / 16	3 / 16	3 / 16	3 / 16	3 / 16	3 / 16
Condenser Fans, Direct-Drive Propeller Type									
Number of Fans per Circuit Fan Diameter: 31.5 in. (800 mm)	8	8	8	8	8	10	10	10	8
Fan Motor, hp (kW)	1.4 (1.05)			1.4 (1.05)			1.4 (1.05)		
Fan & Motor RPM	850			850			850		
Fan Tip Speed, fpm (m/s)	6984 (35)			6984 (35)			6984 (35)		
Airflow, cfm (l/s)	266040 (125556)			288210 (136019)			310380 (146482)		
Remote Evaporator, Direct Expansion Shell and Tube									
Shell Diameter-Tube Length, in. (mm)	26x130 / (660x3300)			26x130 / (660x3300)			26x130 / (660x3300)		
Water Volume, gallons (liters)	225 (850)			220 (831)			220 (831)		
Victaulic inlet/outlet connection in. (mm)	10 (273)			10 (273)			10 (273)		
Maximum Water Pressure, psi (kPa)	152 (1048)			152 (1048)			152 (1048)		
Maximum Refrigerant Pressure, psi (kPa)	325 (2241)			325 (2241)			325 (2241)		

NOTES: A 20 mesh strainer must be placed in the supply water line just prior to the inlet of the evaporator. Care must be exercised when welding pipe or flanges to the evaporator to prevent any slag from entering the vessel.

AWS 530BTH, Remote Evaporator, High Efficiency

Data	AWS530BTH Remote Evap		
	CIRCUIT 1	CIRCUIT 2	CIRCUIT 3
Basic Data			
Unit Capacity @ AHRI tons (kW)	528.3 (1857)		
Unit Operating Charge lbs (kg)	295 (134)	295 (134)	295 (134)
Unit Dimensions LxWxH, in. (mm)	580x88x100 (14722x2225x2548)		
Unit Operating Weight, lbs. (kg)	26997 (12248)		
Unit Shipping Weight, lbs (kg)	26997 (12248)		
Weight-Add for Copper Fins, lbs (kg)	4466 (2026)		
Weight-Add for Louvered Panels, lbs (kg)	1796 (815)		
Weight-Add for Sound Enclosures, lbs (kg)	776 (352)		
Weight-Add for PFCC option, lbs (kg)	120 (55)		
Compressors, Screw, Semi-Hermetic			
Nominal Capacity, tons (kW)	175 (615)	175 (615)	175 (615)
Minimum Capacity (% of Full Load)	8		
Oil charge per circuit, gallons (liters)	6 (23)	6 (23)	6 (23)
Condensers, High Efficiency Fin and Tube Type			
Pumpdown Capacity, lbs (kg)	416 (189)	416 (189)	416 (189)
Coil Inlet Face Area, sq. ft. (sq. m.)	246.1 (22.8)	246.1 (22.8)	246.1 (22.8)
Rows Deep/Fins per Inch	3 / 16	3 / 16	3 / 16
Condenser Fans, Direct-Drive Propeller Type			
Number of Fans per Circuit Fan Diameter: 31.5 in. (800 mm)	10	10	10
Fan Motor, hp (kW)	1.4 (1.05)		
Fan & Motor RPM	850		
Fan Tip Speed, fpm (m/s)	6984 (35)		
Airflow, cfm (l/s)	332550 (156945)		
Remote Evaporator, Direct Expansion Shell and Tube			
Shell Diameter-Tube Length, in. (mm)	26x130 / (660x3300)		
Water Volume, gallons (liters)	220 (831)		
Victaulic inlet/outlet connection in. (mm)	10 (273)		
Maximum Water Pressure, psi (kPa)	152 (1048)		
Maximum Refrigerant Pressure, psi (kPa)	325 (2241)		

NOTES: A 20 mesh strainer must be placed in the supply water line just prior to the inlet of the evaporator. Care must be exercised when welding pipe or flanges to the evaporator to prevent any slag from entering the vessel.

Air-Cooled Chillers

Physical Data—Pathfinder® with Remote Evaporator, Premium Efficiency

AWS 240B through 310B, Remote Evaporator, Premium Efficiency

Data	AWS240BDP Remote Evap		AWS265BDP Remote Evap		AWS290BDP Remote Evap		AWS310BDP Remote Evap	
	Circuit 1	Circuit 2	Circuit 1	Circuit 2	Circuit 1	Circuit 2	Circuit 1	Circuit 2
Basic Data								
Unit Capacity @ AHRI tons (kW)	232.8 (818)		256.4 (901)		277.5 (976)		303.9 (1068)	
Unit Operating Charge lbs (kg)	200 (91)	200 (91)	225 (102)	225 (102)	(235) (107)	(235) (107)	250 (113)	250 (113)
Unit Dimensions LxWxH, in. (mm)	316x88x100 (8022x2225x2548)		351x88x100 (8923x2225x2548)		351x88x100 (8923x2225x2548)		387x88x100 (9823x2225x2545)	
Unit Operating Weight, lbs. (kg)	14142 (6415)		15558 (7057)		16075 (7292)		16970 (7698)	
Unit Shipping Weight, lbs (kg)	14142 (6415)		15558 (7057)		16075 (7292)		16970 (7698)	
Weight-Add for Copper Fins, lbs (kg)	2372 (1076)		2679 (1215)		2679 (1215)		2968 (1346)	
Weight-Add for Louvered Panels, lbs (kg)	1012 (459)		1124 (510)		1124 (510)		1236 (561)	
Weight-Add for Sound Enclosures, lbs (kg)	477 (216)		477 (216)		477 (216)		477 (216)	
Weight-Add for PFCC option, lbs (kg)	160 (73)		160 (73)		160 (73)		160 (73)	
Compressors, Screw, Semi-Hermetic								
Nominal Capacity, tons (kW)	105 (369)	105 (369)	105 (369)	125 (439)	125 (439)	125 (439)	125 (439)	150 (528)
Minimum Capacity (% of Full Load)	15		15		15		15	
Oil charge per circuit, gallons (liters)	4.5 (17)	4.5 (17)	4.5 (17)	5.5 (21)	5.5 (21)	5.5 (21)	5.5 (21)	5.5 (21)
Condensers, High Efficiency Fin and Tube Type								
Pumpdown Capacity, lbs (kg)	333 (151)	333 (151)	375 (170)	375 (170)	375 (170)	375 (170)	416 (189)	416 (189)
Coil Inlet Face Area, sq. ft. (sq. m.)	196.9 (18.3)	196.9 (18.3)	221.5 (20.6)	221.5 (20.6)	221.5 (20.6)	221.5 (20.6)	246.1 (22.8)	246.1 (22.8)
Rows Deep/Fins per Inch	3 / 16	3 / 16	3 / 16	3 / 16	3 / 16	3 / 16	3 / 16	3 / 16
Condenser Fans, Direct-Drive Propeller Type								
Number of Fans per Circuit Fan Diameter: 31.5 in. (800 mm)	8	8	9	9	9	9	10	10
Fan Motor, hp (kW)	1.4 (1.05)		1.4 (1.05)		1.4 (1.05)		1.4 (1.05)	
Fan & Motor RPM	850		850		850		850	
Fan Tip Speed, fpm (m/s)	6984 (35)		6984 (35)		6984 (35)		6984 (35)	
Airflow, cfm (l/s)	177360 (83704)		199530 (94167)		199530 (94167)		221700 (104630)	
Remote Evaporator, Direct Expansion Shell and Tube								
Shell Diameter-Tube Length, in. (mm)	20x154 / (508x3900)		20x154 / (508x3900)		26x154 / (660x3900)		26x154 / (660x3900)	
Water Volume, gallons (liters)	158 (599)		158 (599)		276 (1043)		276 (1043)	
Victaulic inlet/outlet connection in. (mm)	8 (2199)		8 (219)		10 (273)		10 (273)	
Maximum Water Pressure, psi (kPa)	152 (1048)		152 (1048)		152 (1048)		152 (1048)	
Maximum Refrigerant Pressure, psi (kPa)	325 (2241)		325 (2241)		325 (2241)		325 (2241)	

NOTES: A 20 mesh strainer must be placed in the supply water line just prior to the inlet of the evaporator.
Care must be exercised when welding pipe or flanges to the evaporator to prevent any slag from entering the vessel.

AWS 330BDP through 400BDP, Remote Evaporator, Premium Efficiency

Data	AWS330BDP Remote Evap		AWS365BDP Remote Evap		AWS400BDP Remote Evap	
	Circuit 1	Circuit 2	Circuit 1	Circuit 2	CIRCUIT 1	CIRCUIT 2
Basic Data						
Unit Capacity @ AHRI tons (kW)	324.9 (1142)		355 (1248)		385.4 (1355)	
Unit Operating Charge lbs (kg)	260 (118)	260 (118)	260 (118)	300 (136)	310 (141)	310 (141)
Unit Dimensions LxWxH, in. (mm)	387x88x100 (9823x2225x2545)		438x88x100 (11123x2225x2548)		473x88x100 (12024x2225x2548)	
Unit Operating Weight, lbs. (kg)	16970 (7698)		19102 (8665)		20279 (9335)	
Unit Shipping Weight, lbs (kg)	16970 (7698)		19102 (8665)		20279 (9335)	
Weight-Add for Copper Fins, lbs (kg)	2968 (1346)		3256 (1477)		3553 (1612)	
Weight-Add for Louvered Panels, lbs (kg)	1236 (561)		1348 (611)		1460 (662)	
Weight-Add for Sound Enclosures, lbs (kg)	477 (216)		477 (216)		477 (216)	
Weight-Add for PFCC option, lbs (kg)	160 (73)		160 (73)		160 (73)	
Compressors, Screw, Semi-Hermetic						
Nominal Capacity, tons (kW)	150 (528)	150 (528)	150 (528)	175 (615)	175 (615)	175 (615)
Minimum Capacity (% of Full Load)	15		15		15	
Oil charge per circuit, gallons (liters)	5.5 (21)	5.5 (21)	5.5 (21)	6 (23)	6 (23)	6 (23)
Condensers, High Efficiency Fin and Tube Type						
Pumpdown Capacity, lbs (kg)	416 (189)	416 (189)	416 (189)	500 (227)	500 (227)	500 (227)
Coil Inlet Face Area, sq. ft. (sq. m.)	246.1 (22.8)	246.1 (22.8)	246.1 (22.8)	295.3 (27.4)	295.3 (27.4)	295.3 (27.4)
Rows Deep/Fins per Inch	3 / 16	3 / 16	3 / 16	3 / 16	3 / 16	3 / 16
Condenser Fans, Direct-Drive Propeller Type						
Number of Fans per Circuit Fan Diameter: 31.5 in. (800 mm)	10	10	10	12	12	12
Fan Motor, hp (kW)	1.4 (1.05)		1.4 (1.05)		1.4 (1.05)	
Fan & Motor RPM	850		850		850	
Fan Tip Speed, fpm (m/s)	6984 (35)		6984 (35)		6984 (35)	
Airflow, cfm (l/s)	221700 (104630)		243870 (115093)		266040 (125556)	
Remote Evaporator, Direct Expansion Shell and Tube						
Shell Diameter-Tube Length, in. (mm)	26x154 / (660x3900)		26x154 / (660x3900)		26x154 / (660x3900)	
Water Volume, gallons (liters)	259 (979)		259 (979)		259 (979)	
Victaulic inlet/outlet connection in. (mm)	10 (273)		10 (273)		10 (273)	
Maximum Water Pressure, psi (kPa)	152 (1048)		152 (1048)		152 (1048)	
Maximum Refrigerant Pressure, psi (kPa)	325 (2241)		325 (2241)		325 (2241)	

NOTES: A 20 mesh strainer must be placed in the supply water line just prior to the inlet of the evaporator.
Care must be exercised when welding pipe or flanges to the evaporator to prevent any slag from entering the vessel.

Air-Cooled Chillers

Air-Cooled Chillers

Physical Data—Packaged Air-Cooled Screw Chiller, Model AGSD

AGS 140D through 200D, Standard Efficiency

DATA	140DS		160DS		170DS		190DS		200DS	
	Circuit 1	Circuit 2	Circuit 1	Circuit 2	Circuit 1	Circuit 2	Circuit 1	Circuit 2	Circuit 1	Circuit 2
BASIC DATA										
Unit Capacity @ AHRI tons (kW)	137.0 (481.9)		155.2 (545.9)		163.7 (575.8)		176.5 (620.8)		188.9 (664.4)	
Unit Operating Charge lbs (kg)	170 (77)		170 (77)		170 (77)		190 (86)		200 (91)	
Cabinet Dimension L x W x H, in. (mm) s	229.2 x 88 x 100.1 (5821 x 2235 x 2542)		229.2 x 88 x 100.1 (5821 x 2235 x 2542)		229.2 x 88 x 100.1 (5821 x 2235 x 2542)		267.4 x 88 x 100.1 (6792 x 2235 x 2542)		267.4 x 88 x 100.1 (6792 x 2235 x 2542)	
Unit Operating Weight, lbs. (kg)	10990 (4985)		10990 (4985)		10990 (4985)		11730 (5321)		11730 (5321)	
Unit Shipping Weight, lbs (kg)	10415 (4724)		10415 (4724)		10415 (4724)		11170 (5067)		11170 (5067)	
Compressors, Screw, Semi-Hermetic										
Nominal Capacity, tons (kW)	70 (246)	70 (246)	70 (246)	85 (299)	85 (299)	85 (299)	85 (299)	85 (299)	95 (335)	95 (335)
Minimum Capacity (% of Full Load)	12.5		12.5		12.5		12.5		12.5	
Condensers, High Efficiency Fin and Tube with Integral Subcooler										
Pumpdown Capacity, lbs (kg)	399 (181)		399 (181)		399 (181)		438 (199)		438 (199)	
Coil Inlet Face Area, sq. ft. (sq m.)	131.8 (12.2)		131.8 (12.2)		131.8 (12.2)		158.3 (14.7)		158.3 (14.7)	
Condenser Fans, Direct-Drive Propeller										
No. of Fans/Circuit – 30 in. Fan Diameter	5		5		5		6		6	
Fan Motor hp (kW)	2.0 (1.5)		2.0 (1.5)		2.0 (1.5)		2.0 (1.5)		2.0 (1.5)	
Fan & Motor RPM, 60Hz	1140		1140		1140		1140		1140	
60 Hz Fan Tip Speed, fpm (m/s)	8950 (45.5)		8950 (45.5)		8950 (45.5)		8950 (45.5)		8950 (45.5)	
60 Hz Total Unit Airflow, cfm (l/s)	108630 (51280)		108630 (51280)		108630 (51280)		130360 (61530)		130360 (61530)	
Evaporator, Direct-Expansion Shell and Tube										
Shell Diameter-Tube Length, in.(mm)	16 x 108 (406 x 2750)		16 x 108 (406 x 2750)		16 x 108 (406 x 2750)		16 x 108 (406 x 2750)		16 x 108 (406 x 2750)	
Water Volume, gallons (liters)	65.8 (249.4)		65.8 (249.4)		65.8 (249.4)		63.6 (241)		63.6 (241)	
Maximum Water Pressure, psi (kPa)	152 (1048)		152 (1048)		152 (1048)		152 (1048)		152 (1048)	
Maximum Refrigerant Press., psi (kPa)	350 (2413)		350 (2413)		350 (2413)		350 (2413)		350 (2413)	

NOTES: A 20 mesh strainer must be placed in the supply water line just prior to the inlet of the evaporator.
Care must be exercised when welding pipe or flanges to the evaporator to prevent any slag from entering the vessel.

AGS 140DE through 190DE, High Efficiency

DATA	140DE		170DE		190DE	
	Circuit 1	Circuit 2	Circuit 1	Circuit 2	Circuit 1	Circuit 2
BASIC DATA						
Unit Capacity @ AHRI tons (kW)	145.6 (512)		166.9 (586)		186.1 (654)	
Unit Operating Charge lbs (kg)	180 (82)	180 (82)	180 (82)	200 (91)	200 (91)	205 (93)
Cabinet Dimension L x W x H, in. (mm) s	267.4 x 88 x 100.1 (6792 x 2235 x 2542)		267.4 x 88 x 100.1 (6792 x 2235 x 2542)		267.4 x 88 x 100.1 (6792 x 2235 x 2542)	
Unit Operating Weight, lbs. (kg)	11730 (5321)		11730 (5321)		11730 (5321)	
Unit Shipping Weight, lbs (kg)	11170 (5067)		11170 (5067)		11170 (5067)	
Compressors, Screw, Semi-Hermetic						
Nominal Capacity, tons (kW)	70 (246)	70 (246)	70 (246)	85 (299)	85 (299)	95 (335)
Minimum Capacity (% of Full Load)	12.5		12.5		12.5	
Condensers, High Efficiency Fin and Tube with Integral Subcooler						
Pumpdown Capacity, lbs (kg)	438 (199)		438 (199)		438 (199)	
Coil Inlet Face Area, sq. ft. (sq m.)	158.3 (14.7)		158.3 (14.7)		158.3 (14.7)	
Condenser Fans, Direct-Drive Propeller						
No. of Fans/Circuit – 30 in. Fan Diameter	6		6		6	
Fan Motor hp (kW)	2.0 (1.5)		2.0 (1.5)		2.0 (1.5)	
Fan & Motor RPM, 60Hz	1140		1140		1140	
60 Hz Fan Tip Speed, fpm (m/s)	8950 (45.5)		8950 (45.5)		8950 (45.5)	
60 Hz Total Unit Airflow, cfm (l/s)	130360 (61530)		130360 (61530)		130360 (61530)	
Evaporator, Direct-Expansion Shell and Tube						
Shell Diameter-Tube Length, in.(mm)	16 x 108 / (406 x 2750)		16 x 108 / (406 x 2750)		16 x 108 / (406 x 2750)	
Water Volume, gallons (liters)	65.8 (249.4)		65.8 (249.4)		65.8 (249.4)	
Maximum Water Pressure, psi (kPa)	152 (1048)		152 (1048)		152 (1048)	
Maximum Refrigerant Press., psi (kPa)	350 (2413)		350 (2413)		350 (2413)	

NOTES: A 20 mesh strainer must be placed in the supply water line just prior to the inlet of the evaporator.
Care must be exercised when welding pipe or flanges to the evaporator to prevent any slag from entering the vessel.

Air-Cooled Chillers

Physical Data—Air-Cooled Screw Chiller with Remote Evaporator, Model AGSD

AGS 140D through 170D, Remote Evaporator, Standard Efficiency

DATA	140DM Remote Evap		160DM Remote Evap		170DM Remote Evap	
	Circuit 1	Circuit 2	Circuit 1	Circuit 2	Circuit 1	Circuit 2
BASIC DATA						
Unit Capacity @ AHRI tons (kW)	137.0 (481.4)		155.2 (545.4)		(163.7 (575.7))	
Unit Operating Charge lbs (kg)	167 (76)		167 (76)		167 (76)	
Cabinet Dimension L x W x H, in. (mm) s	229.2 x 88 x 100.1 (5821 x 2235 x 2542)		229.2 x 88 x 100.1 (5821 x 2235 x 2542)		229.2 x 88 x 100.1 (5821 x 2235 x 2542)	
Unit Operating Weight, lbs. (kg)	9770		9770		9770	
Unit Shipping Weight, lbs (kg)	9195		9195		9195	
Compressors, Screw, Semi-Hermetic						
Nominal Capacity, tons (kW)	70 (246)	70 (246)	70 (246)	85 (299)	85 (299)	85 (299)
Minimum Capacity (% of Full Load)	15		15		15	
Condensers, High Efficiency Fin and Tube with Integral Subcooler						
Pumpdown Capacity, lbs (kg)	399 (181)	399 (181)	399 (181)	399 (181)	399 (181)	399 (181)
Coil Inlet Face Area, sq. ft. (sq m.)	131.8 (12.2)	131.8 (12.2)	131.8 (12.2)	131.8 (12.2)	131.8 (12.2)	131.8 (12.2)
Condenser Fans, Direct-Drive Propeller						
No. of Fans/Circuit – 30 in. Fan Diameter	5		6		6	
Fan Motor hp (kW)	2.0 (1.5)		2.0 (1.5)		2.0 (1.5)	
Fan & Motor RPM, 60Hz	1140		1140		1140	
60 Hz Fan Tip Speed, fpm (m/s)	8950 (45.5)		8950 (45.5)		8950 (45.5)	
60 Hz Total Unit Airflow, cfm (l/s)	108630 (51280)		108630 (51280)		108630 (51280)	
Evaporator, Direct-Expansion Shell and Tube						
Shell Diameter-Tube Length, in.(mm)	16 x 108 / (406 x 2750)		16 x 108 / (406 x 2750)		16 x 108 / (406 x 2750)	
Water Volume, gallons (liters)	63.6 (241)		63.6 (241)		63.6 (241)	
Refrigerant Charge, lbs (kg)	2.6 (1.2)		2.6 (1.2)		2.6 (1.2)	
Operating Weight lbs (kg)	1675 (759)		1675 (759)		1675 (759)	
Shipping weight, lbs (kg)	1330 (605)		1330 (605)		1330 (605)	
Maximum Water Pressure, psi (kPa)	152 (1048)		152 (1048)		152 (1048)	
Maximum Refrigerant Press., psi (kPa)	350 (2413)		350 (2413)		350 (2413)	

NOTES: A 20 mesh strainer must be placed in the supply water line just prior to the inlet of the evaporator.
Care must be exercised when welding pipe or flanges to the evaporator to prevent any slag from entering the vessel.

AGS 190DM through 210DM, Remote Evaporator, Standard Efficiency

DATA	190DM		200DM		210DM	
	Circuit 1	Circuit 2	Circuit 1	Circuit 2	Circuit 1	Circuit 2
BASIC DATA						
Unit Capacity @ AHRI tons (kW)	176.5 (575.8)		188.9 (664.4)		201.1 (707.4)	
Unit Operating Charge lbs (kg)	187 (85)	197 (90)	197 (90)	197 (90)	197 (90)	197 (90)
Cabinet Dimension L x W x H, in. (mm) s	267.4 x 88 x 100.1 (6792 x 2235 x 2542)		267.4 x 88 x 100.1 (6792 x 2235 x 2542)		267.4 x 88 x 100.1 (6792 x 2235 x 2542)	
Unit Operating Weight, lbs. (kg)	10495		10495		10495	
Unit Shipping Weight, lbs (kg)	9940		9940		9940	
Compressors, Screw, Semi-Hermetic						
Nominal Capacity, tons (kW)	85 (299)	100 (352)	100 (352)	100 (352)	105 (370)	105 (370)
Minimum Capacity (% of Full Load)	15		15		15	
Condensers, High Efficiency Fin and Tube with Integral Subcooler						
Pumpdown Capacity, lbs (kg)	438 (199)		438 (199)		438 (199)	
Coil Inlet Face Area, sq. ft. (sq m.)	158.3 (14.7)		158.3 (14.7)		158.3 (14.7)	
Condenser Fans, Direct-Drive Propeller						
No. of Fans/Circuit – 30 in. Fan Diameter	6		6		6	
Fan Motor hp (kW)	2.0 (1.5)		2.0 (1.5)		2.0 (1.5)	
Fan & Motor RPM, 60Hz	1140		1140		1140	
60 Hz Fan Tip Speed, fpm (m/s)	8950 (45.5)		8950 (45.5)		8950 (45.5)	
60 Hz Total Unit Airflow, cfm (l/s)	130360 (61530)		130360 (61530)		130360 (61530)	
Evaporator, Direct-Expansion Shell and Tube						
Shell Diameter-Tube Length, in.(mm)	16 x 108 / (406 x 2750)		16 x 108 / (406 x 2750)		16 x 108 / (406 x 2750)	
Water Volume, gallons (liters)	63.6 (241)		63.6 (241)		63.6 (241)	
Refrigerant Charge, lbs (kg)	2.6 (1.2)		2.6 (1.2)		2.6 (1.2)	
Operating Weight lbs (kg)	1675 (759)		1675 (759)		1675 (759)	
Shipping weight, lbs (kg)	1330 (605)		1330 (605)		1330 (605)	
Maximum Water Pressure, psi (kPa)	152 (1048)		152 (1048)		152 (1048)	
Maximum Refrigerant Press., psi (kPa)	350 (2413)		350 (2413)		350 (2413)	

NOTES: A 20 mesh strainer must be placed in the supply water line just prior to the inlet of the evaporator.
Care must be exercised when welding pipe or flanges to the evaporator to prevent any slag from entering the vessel.

Air-Cooled Chillers

AGS 140D through 190D, Remote Evaporator, High Efficiency

DATA	140DF Remote Evap		170DF Remote Evap		190DF Remote Evap	
	Circuit 1	Circuit 2	Circuit 1	Circuit 2	Circuit 1	Circuit 2
BASIC DATA						
Unit Capacity @ AHRI tons (kW)	145.6 (512)		166.9 (587)		180.6 (635.2)	
Unit Operating Charge lbs (kg)	177 (81)		177 (81)		207 (94)	
Cabinet Dimension L x W x H, in. (mm) s	267.4 x 88 x 100.1 (6792 x 2235 x 2542)		267.4 x 88 x 100.1 (6792 x 2235 x 2542)		267.4 x 88 x 100.1 (6792 x 2235 x 2542)	
Unit Operating Weight, lbs. (kg)	10495		10495		10495	
Unit Shipping Weight, lbs (kg)	9940		9940		9940	
Compressors, Screw, Semi-Hermetic						
Nominal Capacity, tons (kW)	70 (246)	85 (299)	70 (246)	85 (299)	85 (299)	85 (299)
Minimum Capacity (% of Full Load)	15		15		15	
Condensers, High Efficiency Fin and Tube with Integral Subcooler						
Pumpdown Capacity, lbs (kg)	438 (199)		438 (199)		438 (199)	
Coil Inlet Face Area, sq. ft. (sq m.)	158.3 (14.7)		158.3 (14.7)		158.3 (14.7)	
Condenser Fans, Direct-Drive Propeller						
No. of Fans/Circuit – 30 in. Fan Diameter	6		6		6	
Fan Motor hp (kW)	2.0 (1.5)		2.0 (1.5)		2.0 (1.5)	
Fan & Motor RPM, 60Hz	1140		1140		1140	
60 Hz Fan Tip Speed, fpm (m/s)	8950 (45.5)		8950 (45.5)		8950 (45.5)	
60 Hz Total Unit Airflow, cfm (l/s)	130360 (61530)		130360 (61530)		130360 (61530)	
Evaporator, Direct-Expansion Shell and Tube						
Shell Diameter-Tube Length, in.(mm)	16 x 108 / (406 x 2750)		16 x 108 / (406 x 2750)		16 x 108 / (406 x 2750)	
Water Volume, gallons (liters)	63.6 (241)		63.6 (241)		63.6 (241)	
Refrigerant Charge, lbs (kg)	2.6 (1.2)		2.6 (1.2)		2.6 (1.2)	
Operating Weight lbs (kg)	1675 (759)		1675 (759)		1675 (759)	
Shipping weight, lbs (kg)	1330 (605)		1330 (605)		1330 (605)	
Maximum Water Pressure, psi (kPa)	152 (1048)		152 (1048)		152 (1048)	
Maximum Refrigerant Press., psi (kPa)	350 (2413)		350 (2413)		350 (2413)	

NOTES: A 20 mesh strainer must be placed in the supply water line just prior to the inlet of the evaporator.
Care must be exercised when welding pipe or flanges to the evaporator to prevent any slag from entering the vessel.

Water-Cooled Chiller Product Summary Chart

Model:

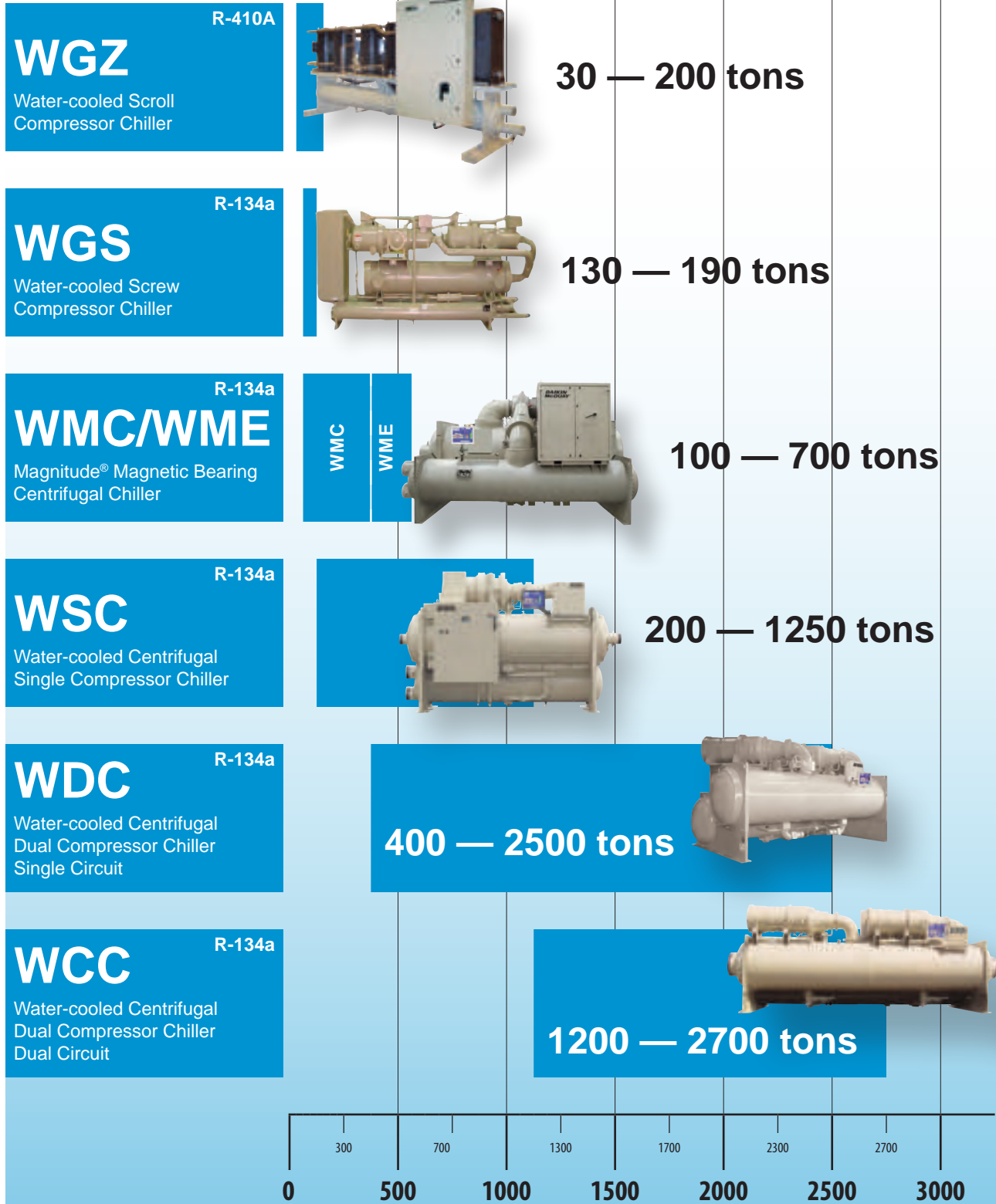

Water-Cooled Chillers

Water-Cooled Chillers

Water-Cooled Scroll Compressor Chillers—30 to 200 Tons

- Efficient—up to 16.1 EER at full load, up to 21.3 EER at part load (IPLV)
- Scroll compressor technology is quiet for installation in sound sensitive environments, sound pressure levels as low as 72 dBA
- Available for water-cooled, remote air-cooled, or evaporative condenser applications
- Controls flexibility—MicroTech® II controls with our Open Choices™ feature for easy integration with the BAS of your choice
- Designed for easy retrofit—fits through a standard three-foot door (sizes up to 130 tons)
- R-410A refrigerant has no phase-out schedule and no ozone depletion potential

For more detail, refer to Catalog 613.

For the most current information, refer to DaikinApplied.com.



Model WGZ-D—30 to 200 tons, R-410A



Water-Cooled Chillers

Physical Data—WGZ Water-Cooled Scroll Compressor Packaged Chiller

WGZ 030D through 055D

WGZ unit size	30		35		40		45		50		55	
Unit capacity @ AHRI tons, (kW) (Note 1)	30.0 (105.5)		34.6 (121.7)		40.7 (143.1)		45.5 (160.0)		51.4 (180.7)		56.4 (198.3)	
Number of Circuits	2		2		2		2		2		2	
Compressors												
Nominal Tons	7.5	7.5	9	9	10	10	12	12	13	13	13	15
Number Per Circuit	2	2	2	2	2	2	2	2	2	2	2	2
Capacity reduction steps percent of compressor displacement												
Staging, Circuit #1 in Lead	25 / 50 / 75 / 100		25 / 50 / 75 / 100		25 / 50 / 75 / 100		25 / 50 / 75 / 100		25 / 50 / 75 / 100		23 / 50 / 73 / 100	
Staging, Circuit #2 in Lead	25 / 50 / 75 / 100		25 / 50 / 75 / 100		25 / 50 / 75 / 100		25 / 50 / 75 / 100		25 / 50 / 75 / 100		27 / 50 / 77 / 100	
Oil Charge per Compressor- oz. (l)	85 (2.5)		110 (3.3)		110 (3.3)		110 (3.3)		110 (3.3)		110 (3.3)	
Condenser												
Number	1		1		1		1		1		1	
No. Refrigerant Circuits	2		2		2		2		2		2	
Diameter- in. (mm)	10 (254)		10 (254)		10 (254)		10 (254)		10 (254)		10 (254)	
Tube Length-in. (mm)	120 (3048)		120 (3048)		120 (3048)		120 (3048)		120 (3048)		120 (3048)	
Design working pressure psig, (kPa):												
Refrigerant Side	500 (3447)		500 (3447)		500 (3447)		500 (3447)		500 (3447)		500 (3447)	
Water Side	232 (1599)		232 (1599)		232 (1599)		232 (1599)		232 (1599)		232 (1599)	
Pump-Out Capacity- lb. (kg) (Note 2)	245.8 (111.7)		245.8 (111.7)		228.2 (103.7)		228.2 (103.7)		205.4 (93.4)		205.4 (93.4)	
Connections												
Victaulic Conn. In & Out - in. (mm)	4 (102)		4 (102)		4 (102)		4 (102)		4 (102)		4 (102)	
Relief Valve, Flare - in. (mm)	5/8 (15.9)		5/8 (15.9)		5/8 (15.9)		5/8 (15.9)		5/8 (15.9)		5/8 (15.9)	
Purge Valve, Flare - in. (mm)	1/2 (12.7)		1/2 (12.7)		1/2 (12.7)		1/2 (12.7)		1/2 (12.7)		1/2 (12.7)	
Vent & Drain - in. (mm) NPT	1/4 (6.4)		1/4 (6.4)		1/4 (6.4)		1/4 (6.4)		1/4 (6.4)		1/4 (6.4)	
Liquid Subcooling	Integral		Integral		Integral		Integral		Integral		Integral	
Evaporator, brazed plate												
Number	1		1		1		1		1		1	
No. Refrigerant Circuits	2		2		2		2		2		2	
Water Volume- gal (l)	1.6 (6.1)		1.8 (6.8)		2.0 (7.6)		2.3 (8.7)		2.6 (9.8)		2.8 (10.6)	
Design working pressure- psig, (kPa):												
Refrigerant Side	653 (4500)		653 (4500)		653 (4500)		653 (4500)		653 (4500)		653 (4500)	
Water Side	653 (4500)		653 (4500)		653 (4500)		653 (4500)		653 (4500)		653 (4500)	
Water connections												
Victaulic Conn. In & Out - in. (mm)	2.5 (65)		2.5 (65)		2.5 (65)		2.5 (65)		2.5 (65)		2.5 (65)	
Relief Valve, Flare - in. (mm)	5/8 (15.9)		5/8 (15.9)		5/8 (15.9)		5/8 (15.9)		5/8 (15.9)		5/8 (15.9)	
Vent & Drain	Field		Field		Field		Field		Field		Field	
Unit dimensions												
Length - in. (mm)	136.0 (3455)		136.0 (3455)		136.0 (3455)		136.0 (3455)		136.0 (3455)		136.0 (3455)	
Width - in. (mm)	32.8 (832)		32.8 (832)		32.8 (832)		32.8 (832)		32.8 (832)		32.8 (832)	
Height - in. (mm)	63.4 (1609)		63.4 (1609)		63.4 (1609)		63.4 (1609)		63.4 (1609)		63.4 (1609)	
Unit weights												
Operating Weight - lb. (kg)	2484 (1127)		2564 (1163)		2615 (1186)		2631 (1193)		2719 (1233)		2731 (1239)	
Shipping Weight - lb. (kg)	2408 (1092)		2488 (1129)		2523 (1144)		2539 (1152)		2606 (1182)		2618 (1188)	
Cir #1 R410A Oper Charge - lb. (kg)	43 (19.5)		43 (19.5)		43 (19.5)		47 (21.4)		47 (21.4)		50 (22.7)	
Cir #2 R410A Oper Charge - lb. (kg)	43 (19.5)		43 (19.5)		43 (19.5)		47 (21.4)		47 (21.4)		50 (22.7)	

1. Capacity certified in accordance with AHRI Standard 550/590
 2. 90% full R410A at 90°F (32°C)

Water-Cooled Chillers

WGZ 060D through 100D

WGZ unit size	60		70		80		90		100	
Unit capacity @ AHRI tons, (kW) (Note 1)	60.5 (212.7)		70.2 (246.8)		78.3 (275.3)		87.1 (306.3)		97.8 (343.9)	
Number of Circuits	2		2		2		2		2	
Compressors										
Nominal Tons	15	15	15/20	15/20	20	20	20/26	20/26	26	26
Number Per Circuit	2	2	2	2	2	2	2	2	2	2
Capacity reduction steps percent of compressor displacement										
Staging, Circuit #1 in Lead	25 / 50 / 75 / 100		22 / 50 / 72 / 100		25 / 50 / 75 / 100		22 / 50 / 72 / 100		25 / 50 / 75 / 100	
Staging, Circuit #2 in Lead	25 / 50 / 75 / 100		22 / 50 / 72 / 100		25 / 50 / 75 / 100		22 / 50 / 72 / 100		25 / 50 / 75 / 100	
Oil Charge per Compressor- oz. (l)	110 (3.3)		110 (3.3)	110 (3.3)	145 (4.3)		145 (4.3)		145 (4.3)	
			145 (4.3)	145 (4.3)						
Condenser										
Number	1		1		1		1		1	
No. Refrigerant Circuits	2		2		2		2		2	
Diameter- in. (mm)	10 (254)		14 (356)		14 (356)		14 (356)		14 (356)	
Tube Length-in. (mm)	120 (3048)		120 (3048)		120 (3048)		120 (3048)		120 (3048)	
Design working pressure psig, (kPa):										
Refrigerant Side	500 (3447)		500 (3447)		500 (3447)		500 (3447)		500 (3447)	
Water Side	232 (1599)		232 (1599)		232 (1599)		232 (1599)		232 (1599)	
Pump-Out Capacity- lb. (kg) (Note 2)	205.4 (93.4)		415.1 (188.7)		397.5 (180.7)		371.1 (168.7)		344.7 (156.7)	
Connections										
Victaulic Conn. In & Out - in. (mm)	4 (102)		4 (102)		4 (102)		4 (102)		4 (102)	
Relief Valve, Flare - in. (mm)	5/8 (15.9)		5/8 (15.9)		5/8 (15.9)		5/8 (15.9)		5/8 (15.9)	
Purge Valve, Flare - in. (mm)	1/2 (12.7)		1/2 (12.7)		1/2 (12.7)		1/2 (12.7)		1/2 (12.7)	
Vent & Drain - in. (mm) NPT	1/4 (6.4)		1/4 (6.4)		1/4 (6.4)		1/4 (6.4)		1/4 (6.4)	
Liquid Subcooling	Integral		Integral		Integral		Integral		Integral	
Evaporator, brazed plate										
Number	1		1		1		1		1	
No. Refrigerant Circuits	2		2		2		2		2	
Water Volume- gal (l)	3.2 (12.0)		5.6 (21.2)		6.3 (23.8)		6.8 (25.7)		8.0 (30.2)	
Design working pressure- psig, (kPa):										
Refrigerant Side	653 (4500)		653 (4500)		653 (4500)		653 (4500)		653 (4500)	
Water Side	653 (4500)		653 (4500)		653 (4500)		653 (4500)		653 (4500)	
Water connections										
Victaulic Conn. In & Out - in. (mm)	2.5 (65)		3 (76)		3 (76)		3 (76)		3 (76)	
Relief Valve, Flare - in. (mm)	5/8 (15.9)		5/8 (15.9)		5/8 (15.9)		5/8 (15.9)		5/8 (15.9)	
Vent & Drain	Field		Field		Field		Field		Field	
Unit dimensions										
Length - in. (mm)	136.0 (3455)		145.5 (3695)		149.6 (3799)		149.4 (3795)		149.4 (3795)	
Width - in. (mm)	32.8 (832)		35.0 (889)		35.0 (889)		35.0 (889)		35.0 (889)	
Height - in. (mm)	63.4 (1609)		65.5 (1664)		65.5 (1664)		65.5 (1664)		65.5 (1664)	
Unit weights										
Operating Weight - lb. (kg)	2771 (1257)		3696 (1676)		4128 (1872)		4320 (1960)		4515 (2048)	
Shipping Weight - lb. (kg)	2658 (1206)		3555 (1613)		3971 (1801)		4140 (1878)		4311 (1955)	
Cir #1 R410A Oper Charge - lb. (kg)	50 (22.7)		74 (33.6)		80 (36.4)		80 (36.4)		90 (40.9)	

1. Capacity certified in accordance with AHRI Standard 550/590
 2. 90% full R410A at 90°F (32°C)

Water-Cooled Chillers

WGZ 115D through 200D

WGZ unit size	115		130		150		170		200	
Unit capacity @ AHRI tons, (kW) (Note 1)	112.9 (397.0)		126.7 (445.5)		148.2 (521.1)		169.3 (595.3)		188.1 (661.4)	
Number of Circuits	2		2		2		2		2	
Compressors										
Nominal Tons	26/30	26/30	30	30	26	26	26	30	30	30
Number Per Circuit	2	2	2	2	3	3	3	3	3	3
Capacity reduction steps percent of compressor displacement										
Staging, Circuit #1 in Lead	22 / 50 / 72 / 100		25 / 50 / 75 / 100		17/33/50/67/83/100		15/33/48/67/81/100		17/33/50/67/83/100	
Staging, Circuit #2 in Lead	22 / 50 / 72 / 100		25 / 50 / 75 / 100		17 / 33 / 50 / 67		19/33/52/67/86/100		17/33/50/67/83/100	
Oil Charge per Compressor- oz. (l)	145 (4.3)	145 (4.3)	213 (6.3)		145 (4.3)		213 (6.3)		213 (6.3)	
	213 (6.3)	213 (6.3)								
Condenser										
Number	1		1		1		1		1	
No. Refrigerant Circuits	2		2		2		2		2	
Diameter- in. (mm)	14 (356)		14 (356)		16 (406.4)		16 (406.4)		16 (406.4)	
Tube Length-in. (mm)	120 (3048)		120 (3048)		144 (3658)		144 (3658)		144 (3658)	
Design working pressure psig, (kPa):										
Refrigerant Side	500 (3447)		500 (3447)		500 (3447)		500 (3447)		500 (3447)	
Water Side	232 (1599)		232 (1599)		232 (1599)		232 (1599)		232 (1599)	
Pump-Out Capacity- lb. (kg) (Note 2)	344.7 (156.7)		344.7 (156.7)		572.3 (260.1)		508.9 (231.3)		508.9 (231.3)	
Connections										
Victaulic Conn. In & Out - in. (mm)	4 (102)		4 (102)		5 (127)		5 (127)		5 (127)	
Relief Valve, Flare - in. (mm)	5/8 (15.9)		5/8 (15.9)		5/8 (15.9)		5/8 (15.9)		5/8 (15.9)	
Purge Valve, Flare - in. (mm)	1/2 (12.7)		1/2 (12.7)		1/2 (12.7)		1/2 (12.7)		1/2 (12.7)	
Vent & Drain - in. (mm) NPT	1/4 (6.4)		1/4 (6.4)		1/4 (6.4)		1/4 (6.4)		1/4 (6.4)	
Liquid Subcooling	Integral		Integral		Integral		Integral		Integral	
Evaporator, brazed plate					Shell and Tube					
Number	1		1		1		1		1	
No. Refrigerant Circuits	2		2		2		2		2	
Water Volume- gal (l)	9.6 (36.3)		10.8 (40.9)		57.6 (218.0)		56.9 (215.4)		56.9 (215.4)	
Design working pressure- psig, (kPa):										
Refrigerant Side	653 (4500)		653 (4500)		450 (3102)		450 (3102)		450 (3102)	
Water Side	653 (4500)		653 (4500)		150 (1034)		150 (1034)		150 (1034)	
Water connections										
Victaulic Conn. In & Out - in. (mm)	3 (76)		3 (76)		8 (203)		8 (203)		8 (203)	
Relief Valve, Flare - in. (mm)	5/8 (15.9)		5/8 (15.9)		5/8 (15.9)		5/8 (15.9)		5/8 (15.9)	
Vent & Drain	Field		Field		1/2 (12.7)		1/2 (12.7)		1/2 (12.7)	
Unit dimensions										
Length - in. (mm)	149.4 (3795)		149.4 (3795)		170.3 (4326)		170.3 (4326)		170.3 (4326)	
Width - in. (mm)	35.0 (889)		35.0 (889)		37.1 (927)		37.1 (927)		37.1 (927)	
Height - in. (mm)	65.5 (1664)		65.5 (1664)		76.9 (1953)		76.9 (1953)		77.7(1974)	
Unit weights										
Operating Weight - lb. (kg)	4434 (2011)		4737 (2149)		6662 (3022)		7214 (3272)		7509 (3406)	
Shipping Weight - lb. (kg)	4230 (1919)		4533 (2056)		5873 (2664)		6377 (2893)		6672 (3026)	
Cir #1 R410A Oper Charge - lb. (kg)	100 (45.5)		100 (45.5)		150 (68.2)		150 (68.2)		150 (68.2)	
Cir #2 R410A Oper Charge - lb. (kg)	100 (45.5)		100 (45.5)		150 (68.2)		150 (68.2)		150 (68.2)	

1. Capacity certified in accordance with AHRI Standard 550/590
 2. 90% full R410A at 90°F (32°C)

Water-Cooled Chillers

Physical Data—WGZ Water-Cooled Scroll Compressor Chiller with Remote Condenser

WGZ 030D through 055D, Less Condenser

WGZ Unit Size	30		35		40		45		50		55	
Tons (kW) (at 44°F LWT/125°F SDT)	26.9 (94.6)		31.2 (109.7)		36.2 (127.3)		40.3 (141.7)		46.3 (162.8)		50.6 (177.9)	
Number of Circuits	2		2		2		2		2		2	
Compressors												
Nominal Tons	7.5	7.5	9	9	10	10	12	12	13	13	13	15
Number per Circuit	2	2	2	2	2	2	2	2	2	2	2	2
Capacity Reduction Steps Percent Of Compressor Displacement												
Staging, Circuit #1 in Lead	25 / 50 / 75 / 100		25 / 50 / 75 / 100		25 / 50 / 75 / 100		25 / 50 / 75 / 100		25 / 50 / 75 / 100		23 / 50 / 73 / 100	
Staging, Circuit #2 in Lead	25 / 50 / 75 / 100		25 / 50 / 75 / 100		25 / 50 / 75 / 100		25 / 50 / 75 / 100		25 / 50 / 75 / 100		27 / 50 / 77 / 100	
Oil Charge per Compressor - oz. (l)	85 (2.5)		110 (3.3)		110 (3.3)		110 (3.3)		110 (3.3)		110 (3.3)	
Evaporator, Brazed Plate												
No. Refrigerant Circuits	2		2		2		2		2		2	
Water Volume - gal (l)	1.6 (6.1)		1.8 (6.8)		2.0 (7.6)		2.3 (8.7)		2.6 (9.8)		2.8 (10.6)	
Design Working Pressure PSIG, (kPa):												
Refrigerant Side	653 (4500)		653 (4500)		653 (4500)		653 (4500)		653 (4500)		653 (4500)	
Water Side	653 (4500)		653 (4500)		653 (4500)		653 (4500)		653 (4500)		653 (4500)	
Victaulic Conn. In & Out - in. (mm)	2.5 (65)		2.5 (65)		2.5 (65)		2.5 (65)		2.5 (65)		2.5 (65)	
Relief Valve, Flare - in. (mm)	5/8 (15.9)		5/8 (15.9)		5/8 (15.9)		5/8 (15.9)		5/8 (15.9)		5/8 (15.9)	
Vent & Drain	Field		Field		Field		Field		Field		Field	
Unit Dimensions												
Length - in. (mm)	137.0 (3480)		137.0 (3480)		137.0 (3480)		137.0 (3480)		137.0 (3480)		137.0 (3480)	
Width - in. (mm)	34.0 (864)		34.0 (864)		34.0 (864)		34.0 (864)		34.0 (864)		34.0 (864)	
Height - in. (mm)	60.0 (1524)		60.0 (1524)		60.0 (1524)		60.0 (1524)		60.0 (1524)		60.0 (1524)	
Unit Weights												
Operating Weight - lb. (kg)	1604 (728)		1690 (767)		1699 (771)		1719 (780)		1740 (789)		1755 (796)	
Shipping Weight - lb. (kg)	1578 (716)		1662 (754)		1669 (757)		1685 (764)		1702 (772)		1714 (778)	

1. Nominal capacity based on unit capacity without derate for refrigerant piping losses

WGZ 060D through 100D, Less Condenser

WGZ Unit Size	60		70		80		90		100	
Tons (kW) (at 44°F LWT/125°F SDT)	55.0 (193.4)		62.5 (219.8)		70.7 (248.6)		79.3 (278.8)		88.7 (311.9)	
Number of Circuits	2		2		2		2		2	
Compressors										
Nominal Tons	15	15	15/20	15/20	20	20	20/26	20/26	26	26
Number per Circuit	2	2	2	2	2	2	2	2	2	2
Capacity Reduction Steps Percent Of Compressor Displacement										
Staging, Circuit #1 in Lead	25 / 50 / 75 / 100		22 / 50 / 72 / 100		25 / 50 / 75 / 100		22 / 50 / 72 / 100		25 / 50 / 75 / 100	
Staging, Circuit #2 in Lead	25 / 50 / 75 / 100		22 / 50 / 72 / 100		25 / 50 / 75 / 100		22 / 50 / 72 / 100		25 / 50 / 75 / 100	
Oil Charge per Compressor - oz. (l)	110 (3.3)		110 (3.3)	110 (3.3)	145 (4.3)		145 (4.3)		145 (4.3)	
			145 (4.3)	145 (4.3)						
Evaporator, Brazed Plate										
No. Refrigerant Circuits	2		2		2		2		2	
Water Volume - gal (l)	3.2 (12.0)		5.6 (21.2)		6.3 (23.8)		6.8 (25.7)		8.0 (30.2)	
Design Working Pressure PSIG, (kPa):										
Refrigerant Side	653 (4500)		653 (4500)		653 (4500)		653 (4500)		653 (4500)	
Water Side	653 (4500)		653 (4500)		653 (4500)		653 (4500)		653 (4500)	
Victaulic Conn. In & Out - in. (mm)	2.5 (63)		3 (76)		3 (76)		3 (76)		3 (76)	
Relief Valve, Flare - in. (mm)	5/8 (15.9)		5/8 (15.9)		5/8 (15.9)		5/8 (15.9)		5/8 (15.9)	
Vent & Drain	Field		Field		Field		Field		Field	
Unit Dimensions										
Length - in. (mm)	137.0 (3480)		144.0 (3658)		144.0 (3658)		144.0 (3658)		144.0 (3658)	
Width - in. (mm)	34.0 (864)		34.0 (864)		34.0 (864)		34.0 (864)		34.0 (864)	
Height - in. (mm)	60.0 (1524)		60.0 (1524)		60.0 (1524)		60.0 (1524)		60.0 (1524)	
Unit Weights										
Operating Weight - lb. (kg)	1786 (810)		2296 (1041)		2649 (1202)		2778 (1260)		2923 (1326)	
Shipping Weight - lb. (kg)	1741 (790)		2228 (1010)		2579 (1170)		2701 (1225)		2841 (1289)	

1. Nominal capacity based on unit capacity without derate for refrigerant piping losses

Water-Cooled Chillers

Water-Cooled Chillers

WGZ 115D through 200D, Less Condenser

WGZ Unit Size	115		130		150		170		200	
Tons (kW) (at 44°F LWT/125°F SDT)	101.9 (358.3)		115.1 (404.7)		133.1 (468.0)		153.7 (540.4)		174.3 (612.8)	
Number of Circuits	2		2		2		2		2	
Compressors										
Nominal Tons	26/30	26/30	30	30	26	26	26	30	30	30
Number per Circuit	2	2	2	2	3	3	3	3	3	3
Capacity Reduction Steps Percent Of Compressor Displacement										
Staging, Circuit #1 in Lead	22 / 50 / 72 / 100		25 / 50 / 75 / 100		17 / 33 / 50 / 67 / 83		15 / 33 / 48 / 67 / 81		17 / 33 / 50 / 67 / 83	
Staging, Circuit #2 in Lead	22 / 50 / 72 / 100		25 / 50 / 75 / 100		17 / 33 / 50 / 67 / 83		19 / 33 / 52 / 67 / 86		17 / 33 / 50 / 67 / 83	
Oil Charge per Compressor - oz. (l)	145 (4.3)	145 (4.3)	213 (6.3)		145 (4.3)		145 (4.3)	213 (6.3)	213 (6.3)	
	213 (6.3)	213 (6.3)								
Evaporator, Brazed Plate										
No. Refrigerant Circuits	2		2		2		2		2	
Water Volume - gal (l)	8.5 (32.1)		10.5 (39.7)		57.6 (218.0)		56.9 (215.4)		56.9 (215.4)	
Design Working Pressure PSIG, (kPa):										
Refrigerant Side	653 (4500)		653 (4500)		450 (3102)		450 (3102)		450 (3102)	
Water Side	653 (4500)		653 (4500)		150 (1034)		150 (1034)		150 (1034)	
Victaulic Conn. In & Out - in. (mm)	3 (76)		3 (76)		8 (203)		8 (203)		8 (203)	
Relief Valve, Flare - in. (mm)	5/8 (15.9)		5/8 (15.9)		5/8 (15.9)		5/8 (15.9)		5/8 (15.9)	
Vent & Drain	Field		Field		½ (12.7)		½ (12.7)		½ (12.7)	
Unit Dimensions										
Length - in. (mm)	144.0 (3658)		144.0 (3658)		154.0 (3912)		154.0 (3912)		154.0 (3912)	
Width - in. (mm)	34.0 (864)		34.0 (864)		34.0 (864)		34.0 (864)		34.0 (864)	
Height - in. (mm)	60.0 (1524)		60.0 (1524)		75.0 (1905)		75.0 (1905)		75.0 (1905)	
Unit Weights										
Operating Weight - lb. (kg)	2878 (1305)		3196 (1450)		4571 (2073)		4841 (2196)		5134 (2334)	
Shipping Weight - lb. (kg)	2792 (1266)		3094 (1403)		4071 (1847)		4347 (1972)		4640 (2105)	

1. Nominal capacity based on unit capacity without derate for refrigerant piping losses

Water-Cooled Screw Compressor Chillers—130 to 190 Tons

- Wide operating map for applications ranging from comfort cooling to ice making
- Two refrigerant circuits improve part load efficiency
- Single main rotor compressor means inherently quieter operation than dual rotor compressors
- Compact size fits through a 3-foot door for lower installed costs
- Solid state starters are standard to provide controlled acceleration and deceleration with less compressor stress and vibration
- Controls flexibility—MicroTech® II controls with our Open Choices™ feature for easy integration with the BAS of your choice
- R-134a refrigerant has no ozone depletion potential and no phase-out schedule

For more detail, refer to Catalog 617.

For the most current information, refer to DaikinApplied.com.



Model WGS—130 to 190 tons, R-134a



Water-Cooled Chillers

Physical Data—WGS Water-Cooled Screw Compressor Packaged Chiller

WGS 130AW through 190AW, Packaged

Physical data	130AW	140AW	160AW	170AW	190AW
Unit capacity @ AHRI conditions tons, (kW) ¹	130.0 (457.1)	140.7 (494.7)	156.7 (551.0)	169.6 (596.3)	182.1 (640.3)
No. circuits	2	2	2	2	2
Compressors					
Nominal horsepower	65 / 65	65 / 80	80 / 80	80 / 95	95 / 95
Number ²	1 / 1	1 / 1	1 / 1	1 / 1	1 / 1
% minimum capacity (modulated) ³	15	13/17	15	14/16	15
Oil charge per compressor, oz (L)	256 (7.6)	256 (7.6)	256 (7.6)	256 (7.6)	256 (7.6)
Condenser					
Number	2	2	2	2	2
No. refrigerant circuits per condenser	1	1	1	1	1
Diameter, in (mm)	12 (305)	12 (305)	12 (305)	12 (305)	12 (305)
Tube length, in (mm)	120 (3048)	120 (3048)	120 (3048)	120 (3048)	120 (3048)
Design w.p. psig, (kPa): refrigerant side	350 (2413)	350 (2413)	350 (2413)	350 (2413)	350 (2413)
Design w.p. psig, (kPa): water side	225 (1551)	225 (1551)	225 (1551)	225 (1551)	225 (1551)
No. of passes	2	2	2	2	2
Pump-out capacity per circuit, lb (kg) ⁴	330 (150)	330 (150)	330 (150)	296 (134)	296 (134)
Connections: water in and out, in (mm) victaulic	4.0 (101)	4.0 (101)	4.0 (101)	4.0 (101)	4.0 (101)
Connections: relief valve, in (mm)	0.5 (12.7)	0.5 (12.7)	0.5 (12.7)	0.5 (12.7)	0.5 (12.7)
Connections: purge valve, flare in (mm)	.625 (15.9)	.625 (15.9)	.625 (15.9)	.625 (15.9)	.625 (15.9)
Connections: vent and drain, in (mm) FPT	0.5 (12.7)	0.5 (12.7)	0.5 (12.7)	0.5 (12.7)	0.5 (12.7)
Connections: liquid subcooling	Integral	Integral	Integral	Integral	Integral
Evaporator					
Number	1	1	1	1	1
No. refrigerant circuits	2	2	2	2	2
Water volume, gallons, (L)	68 (257)	68 (257)	115 (435)	115 (435)	115 (435)
Refrig. side D.W.P., psig, (kPa)	354 (2441)	354 (2441)	354 (2441)	354 (2441)	354 (2441)
Water side D.W.P., psig, (kPa)	150 (1034)	150 (1034)	150 (1034)	150 (1034)	150 (1034)
Water connections: inlet and outlet, in (mm) victaulic	6.0 (152)	6.0 (152)	8.0 (203)	8.0 (203)	8.0 (203)
Water connections: drain and vent (NPT int.)	0.5	0.5	0.5	0.5	0.5
Unit dimensions⁵					
Length, in (mm)	169.9 (4315)	169.9 (4315)	169.9 (4315)	169.9 (4315)	169.9 (4315)
Width, in (mm)	34 (864)	34 (864)	34 (864)	34 (864)	34 (864)
Height, in (mm)	74.6 (1895)	74.6 (1895)	76.6 (1946)	76.6 (1946)	76.6 (1946)
Unit weights					
Operating weight, lb (kg)	8557 (3881)	8557 (3881)	9314 (4225)	9505 (4311)	9505 (4311)
Shipping weight, lb (kg)	7840 (3556)	7840 (3556)	8206 (3722)	8345 (3785)	8345 (3785)
Operating charge per circuit, R-134a, lb (kg)	127 (58)	127 (58)	128 (58)	124 (56)	124 (56)

1. Certified in accordance with AHRI Standard 550/590-98.

2. All units have one compressor per circuit.

3. 80% full R-134a at 90°F (32°C) per refrigerant circuit.

4. On units with mixed capacity compressors, the minimum capacity depends on which compressor is lag.

5. Without sound enclosure – see dimension drawing for enclosure dimensions.

Water-Cooled Chillers

Physical Data—WGS Water-Cooled Screw Compressor Chiller with Remote Condenser

WGS 130AA through 190AA

Physical data	130AA	140AA	160AA	170AA	190AA
Unit capacity @ 44°F LWT and 125°F SDT tons, (kW)	116.0 (407.9)	125.9 (442.7)	136.1 (478.5)	148.0 (520.4)	160.1 (562.9)
No. circuits	2	2	2	2	2
Compressors					
Nominal horsepower	65 / 65	65 / 80	80 / 80	80 / 95	95 / 95
Number ¹	1 / 1	1 / 1	1 / 1	1 / 1	1 / 1
% minimum capacity (modulated) ²	15	13/17	15	14/16	15
Oil charge per compressor, oz (L)	256 (7.6)	256 (7.6)	256 (7.6)	256 (7.6)	256 (7.6)
Condenser					
	Remote				
Evaporator					
Number	1	1	1	1	1
No. refrigerant circuits per condenser	2	2	2	2	2
Water volume, gallons (L)	68 (257)	68 (257)	115 (435)	115 (435)	115 (435)
Refrig. side D.W.P., psig, (kPa)	354 (2441)	354 (2441)	354 (2441)	354 (2441)	354 (2441)
Water side D.W.P., psig, (kPa)	150 (1034)	150 (1034)	150 (1034)	150 (1034)	150 (1034)
Water connections: inlet and outlet, in (mm) viciaulic	6.0 (152)	6.0 (152)	8.0 (203)	8.0 (203)	8.0 (203)
Water connections: drain and vent (npt int.)	0.5	0.5	0.5	0.5	0.5
Unit dimensions⁴					
Length, in (mm)	179.3 (4554)	179.3 (4554)	179.3 (4554)	179.3 (4554)	179.3 (4554)
Width, in (mm)	34.0 (864)	34.0 (864)	34.0 (864)	34.0 (864)	34.0 (864)
Height, in (mm)	60.8 (1544)	60.8 (1544)	62.8 (1595)	62.8 (1595)	62.8 (1595)
Unit weights⁵					
Operating weight, lb (kg)	6265 (2841)	6265 (2841)	7022 (3185)	7022 (3185)	7022 (3185)
Shipping weight, lb (kg)	5659 (2567)	5659 (2567)	6024 (2732)	6024 (2732)	6024 (2732)
Operating charge per circuit, lb (kg) ⁵	35 (15.9)	35 (15.9)	36 (16.5)	36 (16.5)	36 (16.5)

1. All units have one compressor per circuit.

2. On units with mixed capacity compressors, the minimum capacity depends on which compressor is lag.

3. Without sound enclosure – see dimension drawing for enclosure dimensions.

4. Add 650 lbs (295 kg) for sound enclosure.

5. Indoor unit only. Does not include field piping or condenser charge. System charge of R-134a supplied by the installing contractor.

Magnitude® Magnetic Bearing Centrifugal Chillers—100 to 700 Tons

- Reduced operating costs due to exceptional energy savings with part load performance as low as 0.31 kW/ton IPLV
- Quietest sound levels in the industry with sound pressure ratings as low as 76 dBA per AHRI Standard 575
- Lower maintenance costs because the magnetic bearing compressor design eliminates the oil support system
- Positive pressure, oil-free design eliminates performance degradation due to non-condensables and oil contamination of the refrigerant
- R-134a refrigerant with no ozone depletion potential or phase-out schedule
- Seismic compliance with both IBC seismic certification standards and OSPHD pre-approval
- Controls flexibility—Open Choices™ feature for easy integration with the BAS of your choice
- D-Net® Performance Services compatible for proactive support, faster service response, and quicker issue resolution (WMC)

For more detail, refer to Catalog 602.

For the most current information, refer to DaikinApplied.com.



Daikin Magnitude Chiller—100 to 400 tons Model
WMC, R-134a

Magnitude® Magnetic Bearing Centrifugal Chiller—100 to 700 Tons

- Industry leading part load performance contributes to a lower total cost of ownership
- Daikin proprietary compressor design (patent pending)
- Smaller footprint and lower weight than a traditional centrifugal chiller
- Reduced maintenance costs due to the elimination of the oil, oil system, purge system, and shaft seals found in older technology chillers
- Positive pressure, oil-free design eliminates the performance degradation due to non-condensables and oil contamination of the refrigerant.
- Seismic compliance with both IBC seismic certification standards and OSPHD pre-approval
- Controls flexibility—Open Choices™ feature for easy integration with the BAS of your choice

For more detail, refer to Catalog 604.

For the most current information, refer to DaikinApplied.com.



Daikin Magnitude Chiller—400 to 700 tons Model WME, R-134a

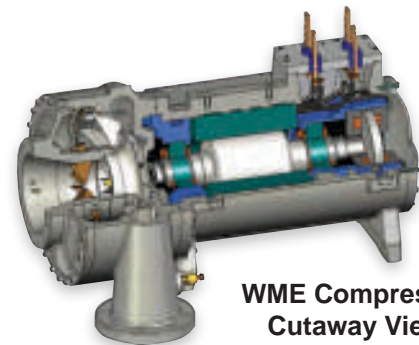

WME Compressor Cutaway View



Daikin Magnitude® Chiller



Water-Cooled Chillers

Physical Data—WMC Evaporator

WMC model	Evaporator model	Tube length	Unit refrigerant charge lb (kg)	Evaporator water volume gal (L)	Insulation area sq ft (m ²)	Number of relief valves
145S, 145D	E2209	9 ft.	550 (249)	38 (145)	66 (6.1)	1
150D	E2212	12 ft.	800 (363)	45 (170)	90 (8.3)	1
250D	E2609	9 ft.	600 (272)	61 (231)	76 (7.1)	1
290D	E2612	12 ft.	1100 (500)	72 (273)	102 (9.4)	1
400D	E3012	12 ft.	1240 (562)	88 (336)	114 (11)	1

1. Refrigerant charge is approximate since the actual charge depends on other variables. Actual charge is shown on unit nameplate.
2. Water capacity is based on standard tube configuration and standard dished heads.

Physical Data—WMC Condenser

WMC model	Condenser model	Tube length	Maximum pumpdown capacity lb (kg)	Evaporator water volume gal (L)	Number of relief valves
145S, 145D	C2009	9 ft.	728 (330)	47 (147)	2
150D	C2012	12 ft.	971 (440)	62 (236)	2
250D	C2209	9 ft.	883 (401)	50 (223)	2
290D	C2212	12 ft.	1174 (533)	72 (273)	2
400D	C2612	12 ft.	1174 (533)	111 (419)	2

1. Condenser pumpdown capacity based on 90% full at 90°F.
2. Water capacity is based on standard configuration and standard heads and can be less with lower tube counts.

WMC Overall Dimensions, 2-Pass Vessels

Data	WMC 145S, 145D	WMC 150D	WMC 250D	WMC 290D	WMC 400D
Length, in (mm)	135 (3421)	170 (4307)	136 (3447)	171 (4333)	169 (4285)
Width, in (mm)	44 (1126)	44 (1126)	48 (1220)	48 (1220)	51 (1289)
Height, in (mm)	81 (2060)	81 (2060)	84 (2134)	84 (2134)	95 (2401)
Overall shipping weight, lb (kg)	5801 (2631)-WMC145S 6230 (2826)-WMC145D	7976 (3618)	7982 (3620)	9601 (4355)	11,838 (5370)

For the most current information on the Magnitude WME unit, please visit DaikinApplied.com/magnitude.

WME Weights and Overall Dimensions (2-pass with Right-hand Connections)

Unit	WME0500S				WME0700S	
	E3012 C2612		E3612 C3012		E3612 C3012	E3612 C3612
	M2 Motor	M3 Motor	M2 Motor	M3 Motor	M4 Motor	M4 Motor
	inch (mm)	inch (mm)	inch (mm)	inch (mm)	inch (mm)	inch (mm)
Length	148 (3764)	148 (3764)	148 (3764)	148 (3764)	148 (3764)	148 (3764)
Width	68 (1737)	71 (1796)	75 (1903)	77 (1962)	77 (1962)	79 (2012)
Height	95 (2421)	95 (2421)	99 (2523)	99 (2523)	99 (2523)	105 (2662)
Operating Weight, lbs (kg)	15,036 (6,820)	16,086 (7,297)	19,580 (8,882)	20,630 (9,358)	22,010 (9,984)	25,255 (11,455)

Magnetic Bearing Compressors— As Reliable As They Are Efficient

- Magnetic bearings eliminate mechanical seals and wear surfaces for longer machine life
- The simplicity of a direct-drive motor and shaft eliminates gears, slide valves and extra parts to increase reliability
- VFD designed as an integrated component with the compressor and optimized by digital controls to reduce power consumption while maximizing chiller performance
- Reduced in-rush current by utilizing a VFD; a gradual soft start that lessens mechanical and thermal stresses leading to increased motor life
- Onboard digital controls to continuously monitor operating status and provide fault protections
- Oil-free design eliminates oil management systems for improved compressor and system reliability. The oil-free design also eliminates the possibility of efficiency robbing oil contamination of heat-transfer surfaces

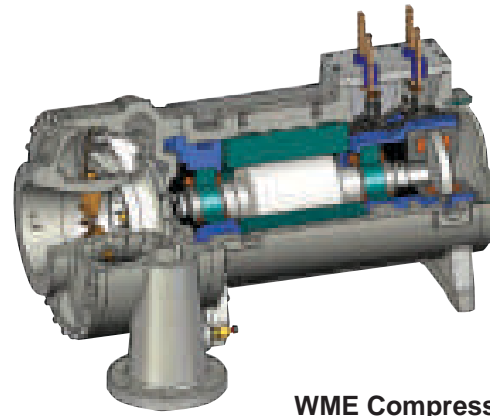

**WME Compressor
Cutaway View**

Why Magnetic Bearing Compressors Are the Right Technology for Today

The magnetic bearing compressor was developed to improve performance, reliability and reduce service requirements as compared with conventional centrifugal compressor designs. The magnetic bearing compressor is a single rotating component – the compressor shaft – levitated on a magnetic cushion.

This cushion results in the shaft not being in contact with any other part of the compressor while operating. The compressor shaft is kept perfectly aligned in all directions by sensors at each magnetic bearing providing real-time feedback to the digital bearing control system. This cutting edge magnetic bearing technology enables outstanding energy efficiency and reliable, long-life operation.



Power Protection for Long-Term Viability

The compressor's ability to protect itself from low power quality, and to have controlled response in power loss situations, is a feature that enhances long-term compressor viability and reduces downtime. Magnitude chillers can often remain on-line through minor power disturbances and some models meet industry voltage sag immunity standard SEMI F47.

In extreme or extended power disruptions, Magnitude compressors are designed to regenerate power from the spinning motor and feed that power back to the bearings and control system. This regenerative power mode allows the compressor shaft to coast down and gently reseat onto touchdown bearings.

Water-Cooled Centrifugal Compressor Water Chillers—200 to 2,700 Tons

- R-134a refrigerant with no ozone depletion potential and no phase-out schedule
- Smallest footprint per ton in the industry to optimize equipment room space
- Controls flexibility—MicroTech® II controls with our Open Choices™ feature for easy integration with the BAS of your choice
- Moveable diffuser geometry provides superior part load performance with or without a VFD
- Dual compressor chiller models offer efficiency choices: WDC for superior part load efficiency and WCC for exceptional full load efficiency
- Seismic compliance with both IBC seismic certification standards and OSPHD pre-approval
- D-Net® Performance Services compatible for proactive support, faster service response, and quicker issue resolution

For more detail, refer to Catalog 605.

For the most current information, refer to DaikinApplied.com.



Model WDC dual compressor—single circuit
400 to 2500 tons



Model WSC single compressor
200 to 1250 tons



Model WCC dual compressor—dual circuit
1200 to 2700 tons



Centrifugal Compressor Water Chillers Features

- **Quiet compressor design** with movable discharge geometry that reduces sound levels at part load and optional refrigerant injection system absorbs sound energy for even quieter operation.
- **Variable frequency drive option** optimizes part load efficiency, a key performance feature since most chillers operate at part load 99% of their life.
- **Positive pressure design** does not require a purge system and offers reduced maintenance of seals and hydrodynamic bearings.
- **Easy integration** with our Open Choices™ feature using BACnet®, LONWORKS® or Modbus® communication options without an expensive gateway panel.
- **R-134a refrigerant** offers a significantly smaller footprint than R-123 unit designs and has no ozone depletion potential or phase-out schedule.
- **Knockdown option** for total knockdown of the unit allows entry to equipment rooms where access is limited, making it ideal for replacement projects.
- **World class unloading capability** without hot gas bypass. The movable discharge diffuser increases stability while reducing sound and vibration.
- **Power failure coast-down protection** helps guard against bearing damage after a power failure.
- **Touch screen operator panel** is graphically intuitive and easy to use for enhanced operator productivity. Important status and control information is available at a glance or a touch.
- **Seismic compliance** option for both IBC seismic certification standards and OSHPD pre-approval.

Daikin Dual Compressor Centrifugal Chillers All the

features and benefits of the single compressor models plus:

- Single circuit parallel-flow model provides superior part load efficiency, especially with optional variable frequency drives
- Dual circuit series-counterflow model delivers exceptional full load efficiency
- Automatic backup with at least 60% of the chiller design capacity available on single circuit units and 50% on dual circuit units
- Positive pressure R-134a design has a significantly smaller footprint than R-123 designs

Physical Data—Model WSC Series Single Compressor Chiller

Chiller model	Nominal capacity tons (kW)	Dimensions (in) ¹			Max. unit operating weight (lb) ¹
		Maximum length	Maximum width (w/o starter)	Maximum height	
WSC 063	200–300 (700–1050)	175 (4445)	96 (2438)	96 (2438)	16,769 (7606)
WSC 079/087	300–600 (1050–2100)	175 (4445)	80 (2032)	105 (2667)	24,999 (11,340)
WSC 100/113/126	600–1300 (2100–4550)	181 (4597)	104 (2642)	106 (2692)	43,017 (19,513)

1. Lengths in inches (mm), weight in pounds (kg).

Physical Data—Models WDC and WCC Dual Compressor Chiller

Chiller model	Nominal capacity tons (kW)	Dimensions (in) ¹			Max. unit operating weight (lb) ¹
		Maximum length	Maximum width (w/o starter)	Maximum height	
WDC 063	400–600 (1400–2100)	221 (5623)	64 (1619)	90 (2280)	28,815 (13,070)
WDC 079	600–700 (2100–2450)	224 (5698)	74 (1865)	106 (2686)	38,515 (17,470)
WDC 087	700–1200 (2450–4200)	224 (5698)	74 (1865)	106 (2686)	39,875 (18,087)
WCC100/113/126	1200–2700 (4200–8750)	230 (5848)	110 (2792)	116 (2956)	68,996 (31,296)
WCC100/113/126	1200–2700 (4200–9450)	278 (7071)	104 (2651)	110 (2084)	65,806 (29,849)

1. Lengths in inches (mm), weight in pounds (kg).

Water-Cooled Chillers

Single Circuit vs. Dual Circuit – What’s the best dual compressor model for your system?

Dual Compressor, Single Circuit

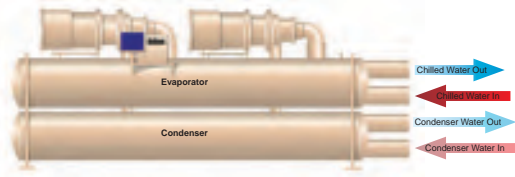

Single Circuit, WDC Chillers have a single-refrigerant circuit for the evaporator and condenser with two compressors running in parallel and are available in one, two or three-pass configurations. Their salient feature is that at single-compressor, part load operation, the running compressor can utilize the entire chiller’s heat transfer surface, providing outstanding part load performance.

- Overall lowest energy consumption with best part load performance
- Smaller chilled water plant where unit unloading is expected
- Floor space is limited (16-foot vessel length compared to 20-foot for WCC unit)
- Two or three pass vessels are required, typical of retrofit applications
- Built-in redundancy—a single compressor will provide 60% of full load capacity

Dual Compressor, Dual Circuit

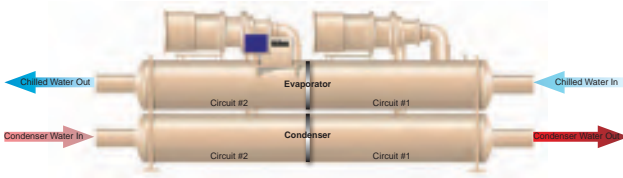

Dual Circuit, WCC Counterflow Chillers have a separate refrigerant circuit for each compressor. They are available in single pass only. They provide the high full load efficiency advantage of two separate chillers arranged for counterflow operation in a single, compact unit.

- Lowest kW per ton performance at full load
- Large central plant where cycling chillers for system capacity reduction is expected (three or more chillers)
- High chilled water delta-T and single pass low water pressure drops
- Built-in redundancy—a single compressor will provide 50% of full load capacity
- High efficiency and large capacity with series flow

This page intentionally left blank.

Templifier™ Water Heater Product Summary Chart

Model:

TGZ

Templifier™ Water Heater

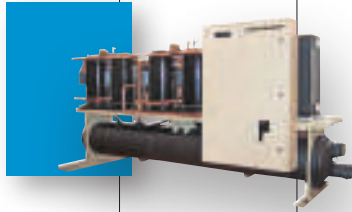

600 — 3,100 MBh

TSC

Templifier™ Water Heater

3,000 — 18,000 MBh

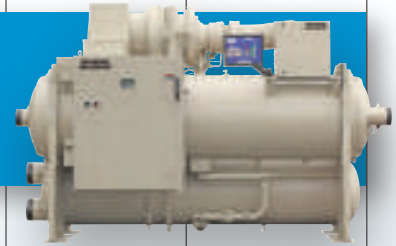

MBh

0 1,500 3,000 4,500 6,000 7,500 9,000 10,500 12,000 13,500 15,000 16,500 18,000

Templifier Water Heaters

Templifier™ Water Heaters—600 to 18,000 MBh

- Designed to economically turn waste heat into useful heat for loads such as space heating and domestic hot water
- Heats water more economically than fossil fuel or electric resistance heaters
- Can reduce the burden on overloaded boilers and/or cooling towers, thereby delaying or eliminating the capital expenditure required to increase their capacity
- Model TSC Templifier units are equipped with centrifugal compressors. Capacities range from 3,000 to 18,000 MBh with hot water temperatures up to 140°F (60°C)
- Model TGZ Templifier units are equipped with scroll compressors using R-134a. Capacities range from 600 to 3,100 MBh with hot water temperatures up to 160°F (71°C)
- Controls flexibility—MicroTech® II controls with our Open Choices™ feature for easy integration with the BAS of your choice

For more detail, refer to Catalog 614.

For the most current information, refer to DaikinApplied.com.



Model TSC Templifier Water Heater
3,000 to 18,000 MBh (880 to 6,300 kW), R-134a



Model TGZ Templifier Water Heater
600 to 3,100 MBh (175 to 900 kW), R-134a



Templifier Water Heaters

Which Daikin Templifier Model is Right for You?



TGZ Scroll Templifier



TSC Centrifugal Templifier

Heating Capacity	600 to 3,100 MBh (175 to 900 kW)	3,000 to 18,000 MBh (880 to 5,214 kW)
Maximum hot water temperature	160°F (71°C)	140°F (60°C)
Refrigerant	R-134a	R-134a
Communication options	BACnet®, Modbus®, LonWORKS®	

TSC Centrifugal Compressor Templifier Water Heater

Physical Data— TSC 063 through 126

TSC unit size	TSC 063	TSC 079	TSC 087	TSC 100	TSC 126
Compressor					
Model	CE 063	CE 079	CE 087	CE 100	CE 126
Number	1	1	1	1	1
Motor speed 60/50 Hz	3550/2960	3550/2960	3550/2960	3550/2960	3550/2960
Condenser					
Diameter/length, in/ft	22/12	26/12	36/12	36/12	36/12
Diameter/length, (mm/mm)	(559/3658)	(660/3658)	(914/3658)	(914/3658)	(914/3658)
Water volume, gal (L)	76 (290)	111 (419)	234 (884)	234 (884)	234 (884)
Two pass connection size, in (mm)	8 (203)	8 (203)	12 (305)	12 (305)	12 (305)
Working press., water, psi (kPa)	150 (1034)	150 (1034)	150 (1034)	150 (1034)	150 (1034)
Working press., refig, psi (kPa)	300 (2070)	300 (2070)	300 (2070)	300 (2070)	300 (2070)
Evaporator					
Diameter/length, in/ft	26/12	30/12	42/12	42/12	48/12
Diameter/length, (mm/mm)	(660/3658)	(762/3658)	(1067/3658)	(1067/3658)	(1219/3658)
Water volume, gal (L)	72 (273)	101 (381)	222 (841)	222 (841)	327 (1237)
Two pass connection size, in (mm)	8 (203)	10 (254)	14 (356)	14 (356)	18 (457)
Working press., water, psi (kPa)	150 (1034)	150 (1034)	150 (1034)	150 (1034)	150 (1034)
Working press., refig, psi (kPa)	200 (1380)	200 (1380)	200 (1380)	200 (1380)	200 (1380)
Dimensions					
Length, in (mm)	169 (4293)	175 (4445)	175 (4445)	175 (4445)	175 (4445)
Width w/o starter, in (mm)	48 (1219)	56 (1422)	86 (2184)	86 (2184)	104 (2642)
Height, in (mm)	80 (2032)	88 (2235)	111 (2819)	99 (2515)	99 (2515)
Weights, (w/starter)					
Shipping, lb (kg)	12,777 (5796)	15,835 (7183)	24,657 (11,170)	27,657 (13,545)	33,224 (15,070)
Operating, lb (kg)	14,017 (6358)	17,501 (7938)	28,460 (12,892)	31,460 (14,270)	38,823 (17,610)
Weights, (w/o starter)					
Shipping, lb (kg)	11,577 (5251)	14,635 (6638)	23,457 (10,626)	26,457 (12,001)	32,024 (14,526)
Operating, lb (kg)	12,517 (5678)	16,301 (7394)	27,260 (12,349)	30,260 (13,726)	37,623 (17,066)

Templifier Water Heaters

TGZ Scroll Compressor Templifier Water Heaters

Physical Data—TGZ 040B through 100B, R-134a

TGZ Unit Model	TGZ040B		TGZ050B		TGZ060B		TGZ080B		TGZ100B	
No. of Circuits	2		2		2		2		2	
Compressors										
Nominal Horsepower	10	10	13	13	15	15	20	20	25	25
Number per Circuit	2	2	2	2	2	2	2	2	2	2
Unloading Steps, %	25/50/75/100		25/50/75/100		25/50/75/100		25/50/75/100		25/50/75/100	
Oil Charge per compressor, oz (l)	110 (3.3)		110 (3.3)		110 (3.3)		158 (4.7)		200 (5.9)	
Condenser										
Number	1		1		1		1		1	
No. Refrigerant Circuits	2		2		2		2		2	
Diameter, in. (mm)	10.75 (273)		10.75 (273)		10.75 (273)		14 (356)		14 (356)	
Tube Length, in (mm)	122 (3099)		122 (3099)		122 (3099)		122 (3099)		122 (3099)	
Design water pressure, psig (kPa):										
Refrigerant Side	500 (3447)		500 (3447)		500 (3447)		500 (3447)		500 (3447)	
Water Side	232 (1599)		232 (1599)		232 (1599)		232 (1599)		232 (1599)	
Relief Valve Setting, psig (kPa)	500 (3447)		500 (3447)		500 (3447)		500 (3447)		500 (3447)	
No. Of Water Passes - Standard	4		4		4		4		4	
No. Of Water Passes - Optional	2		2		2		2		2	
Water Volume, gallons (l)	13.6 (51.5)		13.6 (51.5)		16.3 (61.8)		27.5 (104)		27.5 (104)	
Pump-Down Capacity lb., (kg)	121.7 (55.2)	121.7 (55.2)	121.7 (55.2)	121.7 (55.2)	107.3 (48.7)	107.3 (48.7)	186 (84)	186 (84)	186 (84)	186 (84)
Connections										
Water In & Out, in., (mm) (4 Pass)	3 (76)		3 (76)		3 (76)		4 (102)		4 (102)	
Water In & Out, in., (mm) (2 Pass)	4 (102)		4 (102)		4 (102)		4 (102)		4 (102)	
Relief Valve, Flare in., (mm)	5/8 (15.9)		5/8 (15.9)		5/8 (15.9)		5/8 (15.9)		5/8 (15.9)	
Purge Valve, Flare in., (mm)	5/8 (15.9)		5/8 (15.9)		5/8 (15.9)		5/8 (15.9)		5/8 (15.9)	
Vent & Drain, in (mm) FPT	1/2 (12.7)		1/2 (12.7)		1/2 (12.7)		1/2 (12.7)		1/2 (12.7)	
Liquid Sub-cooling	Integral		Integral		Integral		Integral		Integral	
Evaporator, brazed-plate										
Number	1		1		1		1		1	
No. Refrigerant Circuits	2		2		2		2		2	
Water Volume, gallons (l)	3.7 (14.0)		5.0 (18.9)		5.0 (18.9)		8.7 (32.9)		8.7 (32.9)	
Refrigerant Side D.W.P., psig (kPa)	450 (3102)		450 (3102)		450 (3102)		450 (3102)		450 (3102)	
Relief Valve Setting, psig (kPa)	450 (3102)		450 (3102)		450 (3102)		450 (3102)		450 (3102)	
Water Side D.W.P., psig (kPa)	450 (3102)		450 (3102)		450 (3102)		450 (3102)		450 (3102)	
Water connections:										
In & Out, in. (mm) Victaulic	3 (76)		3 (76)		3 (76)		3 (76)		3 (76)	
Drain & Vent in Field Piping	Field Supplied		Field Supplied		Field Supplied		Field Supplied		Field Supplied	
Unit dimensions										
Length, in. (mm)	138 (3506)		138 (3506)		138 (3506)		149.1 (3787)		150.7 (3828)	
Width, in. (mm)	33 (838)		33 (838)		33 (838)		35.2 (894)		35.2 (894)	
Height, in. (mm)	63.4 (1610)		63.4 (1610)		63.4 (1610)		65.5 (1664)		65.5 (1664)	
Unit weights										
Operating weight, lb. (kg)	2604 (1181)		2644 (1199)		2699 (1224)		4422 (2006)		4749 (2154)	
Shipping weight, lb. (kg)	2434 (1104)		2464 (1118)		2496 (1132)		4116 (1867)		4418 (2004)	
R-134a Ref. Charge, lb. (kg)	45 (20.4)	45 (20.4)	45 (20.4)	45 (20.4)	50 (22.7)	50 (22.7)	85 (38.6)	85 (38.6)	90 (40.8)	90 (40.8)

Templifier Water Heaters

Physical Data—TGZ 110B through 190B, R-134a

TGZ Unit Model	TGZ110B		TGZ120B		TGZ150B		TGZ170B		TGZ190B	
No. Of Circuits	2		2		2		2		2	
Compressors										
Nominal Horsepower	25	30	30	30	25	25	25	30	30	30
Number per Circuit	2	2	2	2	3	3	3	3	3	3
Staging, 4 Stages, Circuit #1 in Lead	23/50/73/100		25/50/75/100		—		—		—	
Staging, 4 Stages, Circuit #2 in Lead	27/50/77/100		25/50/75/100		—		—		—	
Staging, 6 Stages, Circuit #1 in Lead	—		—		17/33/50/67/83/100		15/33/48/67/81/100		17/33/50/67/83/100	
Staging, 6 Stages, Circuit #2 in Lead	—		—		17/33/50/67/83/100		19/33/52/67/85/100		17/33/50/67/83/100	
Oil Charge per compressor, oz. (l)	200 (5.9)	213 (6.3)	213 (6.3)		200 (5.9)		200 (5.9)	213 (6.3)	213 (6.3)	
Condenser										
Number	1		1		1		1		1	
No. Refrigerant Circuits	2		2		2		2		2	
Diameter, in. (mm)	16.0 (406.4)		16.0 (406.4)		16 (406.4)		16 (406.4)		16 (406.4)	
Tube Length, in (mm)	120 (3048)		120 (3048)		144 (3658)		144 (3658)		144 (3658)	
Design water pressure, psig (kPa):										
Refrigerant Side	500 (3447)		500 (3447)		500 (3447)		500 (3447)		500 (3447)	
Water Side	232 (1599)		232 (1599)		232 (1599)		232 (1599)		232 (1599)	
Relief Valve Setting, psig (kPa)	500 (3447)		500 (3447)		500 (3447)		500 (3447)		500 (3447)	
No. Of Water Passes - Standard	4		4		4		4		4	
No. Of Water Passes - Optional	2		2		2		2		2	
Water Volume, gallons (l)	35.4 (134)		35.4 (134)		42.5 (160.9)		47.1 (178.4)		47.1 (178.4)	
Pump-Down Refrigerant Capacity, lb. (kg)	252 (114)	252 (114)	252 (114)	252 (114)	302 (137)	302 (137)	277 (126)	277 (126)	277 (126)	277 (126)
Connections										
Water In & Out, in., (mm) (4 Pass)	4 (102)		4 (102)		4 (102)		4 (102)		4 (102)	
Water In & Out, in., (mm) (2 Pass)	5 (127)		5 (127)		5 (127)		5 (127)		5 (127)	
Relief Valve, Flare in., (mm)	5/8 (15.9)		5/8 (15.9)		5/8 (15.9)		5/8 (15.9)		5/8 (15.9)	
Purge Valve, Flare in., (mm)	5/8 (15.9)		5/8 (15.9)		5/8 (15.9)		5/8 (15.9)		5/8 (15.9)	
Vent & Drain, in (mm) FPT	1/2 (12.7)		1/2 (12.7)		1/2 (12.7)		1/2 (12.7)		1/2 (12.7)	
Liquid Sub-cooling	Integral		Integral		Integral		Integral		Integral	
Evaporator, brazed-plate										
Number	1		1		1		1		1	
No. Refrigerant Circuits	2		2		2		2		2	
Water Volume, gallons (l)	9.7 (36.7)		9.7 (36.7)		57.6 (218)		56.9 (215.4)		56.9 (215.4)	
Refrigerant Side D.W.P., psig, (kPa)	450 (3102)		450 (3102)		450 (3102)		450 (3102)		450 (3102)	
Relief Valve Setting, psig (kPa)	450 (3102)		450 (3102)		150 (1034)		150 (1034)		150 (1034)	
Water Side D.W.P., psig, (kPa)	450 (3102)		450 (3102)		450 (3102)		450 (3102)		450 (3102)	
Water connections:										
In & Out, in. (mm) Victaulic	3 (76)		3 (76)		8 (203)		8 (203)		8 (203)	
Drain & Vent in Field Piping	Field Supplied		Field Supplied		1/2 (12.7)		1/2 (12.7)		1/2 (12.7)	
Unit dimensions										
Length, in. (mm)	148.8 (3780)		148.8 (3780)		170.1 (4321)		170.1 (4321)		170.1 (4321)	
Width, in. (mm)	35.2 (894)		35.2 (894)		36.8 (935)		36.8 (935)		36.8 (935)	
Height, in. (mm)	67 (1702)		67 (1702)		77.7 (1974)		77.7 (1974)		77.7 (1974)	
Unit weights										
Operating WT., lb., (kg)	5373 (2437)		5319 (2413)		7877 (3573)		7991 (3625)		7972 (3616)	
Shipping WT., lb. (kg)	4967 (2253)		4913 (2229)		7019 (3184)		7101 (3221)		7082 (3212)	
R-134a Ref. Charge, lb. (kg)	110 (49.9)	110 (49.9)	110 (49.9)	110 (49.9)	140 (63.5)	140 (63.5)	150 (68)	150 (68)	150 (68)	150 (68)

Modular Central Plant

Modular Central Plants—75 to 720 Tons Per Single Package, up to 3,750 Total Tons

- The high efficiency, low cost alternative to site-built central plants
- Combines chiller, cooling tower, pumps, and interconnecting condenser water piping in pre-engineered and pre-assembled modules
- Sizes from 75 to 750 tons in a single compact package with a modular design that allows central plants up to 3,750 tons
- Reduces trade coordination costs and site assembly time
- Lower costs per ton compared to traditional site-built plants
- Available with Daikin water-cooled scroll, screw, centrifugal, and magnetic bearing compressor chillers

For more detail, refer to ASP 31-355.

For the most current information, refer to DaikinApplied.com.



Modular Central Plant



Modular Central Plant

The High Efficiency, Low Cost Alternative to Site-Built Central Plants

The Daikin Modular Central Plant (MCP) combines a chiller and/or boiler, cooling tower, pumps and interconnecting condenser water piping in a pre-engineered and pre-assembled module.

Daikin Advantages

Quality - The MCP factory fabrication and assembly provides quality that exceeds outside field practices. Galvanized finish on all structural steel and condenser water piping is standard.

Efficiency –The Daikin chillers used in the MCP are industry leaders in efficiency. In addition, the MCP comes standard with cooling tower VFDs for enhanced part load performance.

Simplicity – Single source OEM supplier.

Reliability – ETL inspected and certified.



Data Centers



Schools and Colleges

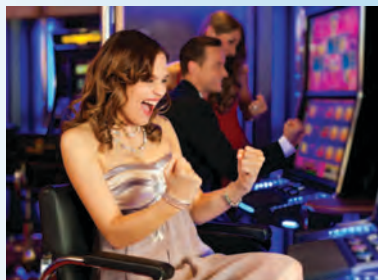

Hospitality



Healthcare

Where the MCP Shines

- Fast track projects with critical deadlines and tight construction schedules.
- Limited space facilities where you don't want to sacrifice interior space to house a central chiller plant or a boiler room.
- Cost conscious projects because the MCP has a lower cost per ton than a brick-and-mortar central plant.
- High growth buildings or businesses with a strong likelihood of expansion. The modular design of the Modular Central Plant allows plants up to 3,750 tons with standard catalog product and virtually limitless with customized product.

Innovation Inside and Outside the Box

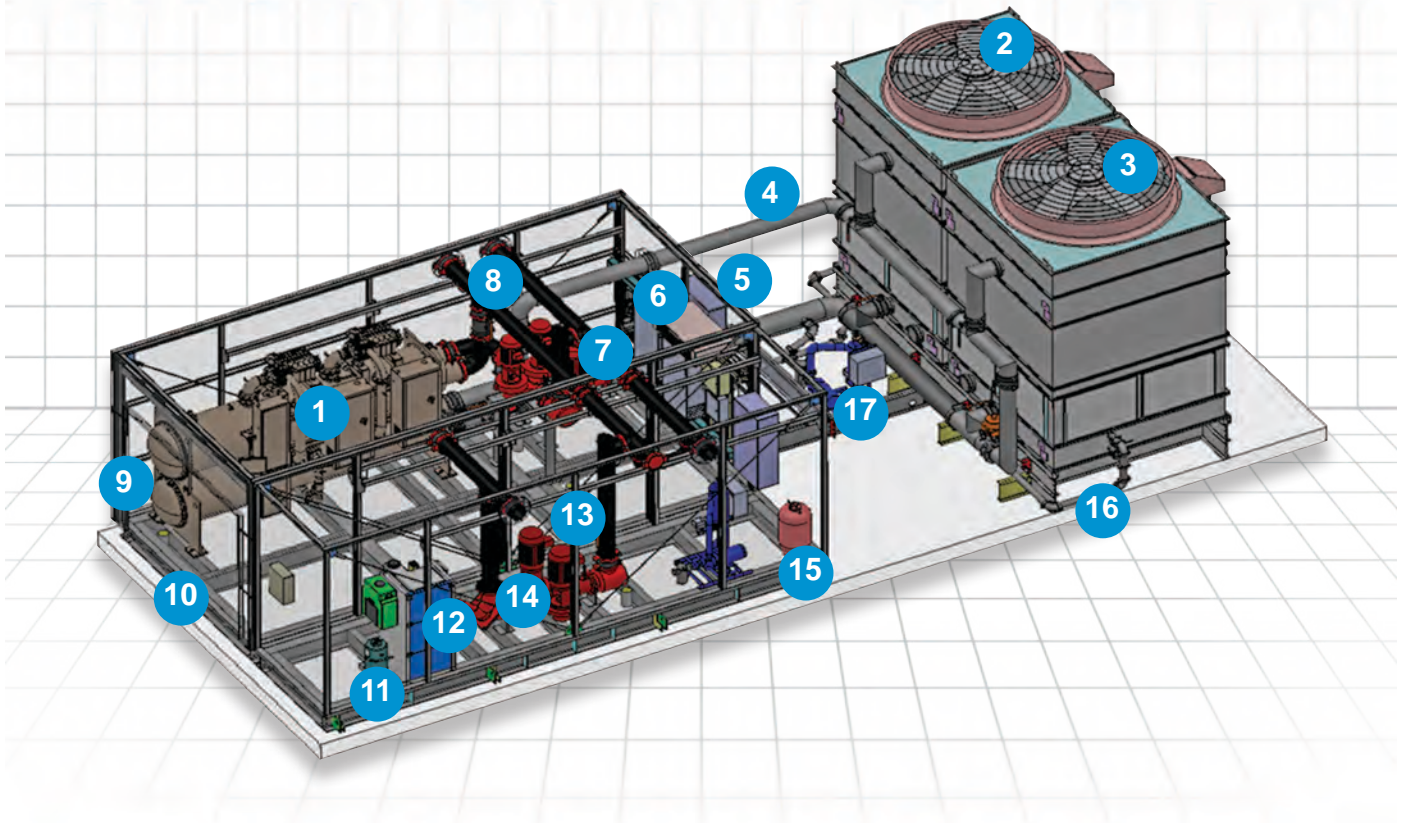

Standard Features and Options

- | | | |
|--|---|---|
| <ul style="list-style-type: none"> 1 Daikin chiller, 100 to 1,000 tons per module 2 Cooling tower with VFD 3 Redundant cooling tower (optional) 4 Schedule 40 steel condenser piping, hot dipped galvanized finish 5 Electrical distribution panel, single point power per module 6 Enclosure HVAC 7 MCP controls | <ul style="list-style-type: none"> 8 Schedule 40 steel system piping welded with mechanical coupling connections 9 Motor roll-up access door 10 Fully welded steel structure, galvanized finish 11 Internal floor drains piped to single discharge 12 Water treatment equipment and eyewash 13 Vertical in-line pump suction guide, 3-way valve 14 Redundant pump (optional) | <ul style="list-style-type: none"> 15 Expansion tank and make-up water 16 Tower drain and make-up water piping 17 Tower basin filtration (optional) <p>For a complete list of available options, see page 172.</p> <p>Daikin chillers can integrate with a building automation system using standard open protocols.</p> |
|--|---|---|

Modular Central Plant

Packaged installation – ideal for fast-track projects



Boiler Module



Pump Module



MCP with Dual Chillers Inside

Available Options

- Redundant primary and condenser water pumps
- Redundant cooling towers
- Tower basin filtration
- Tower basin heater
- Stainless steel hot and cold water basins
- Complete stainless steel tower construction
- Winterized MCP for cold climate applications
- Variable primary pumping
- Primary/secondary pumping
- Air separator
- Air and dirt separator
- 65,000 AIC breakers
- MCP extended parts and labor warranty
- Waterside economizer
- Chilled and condenser water pipe insulation
- Sealed combustion boilers for heating and domestic hot water applications
- Zone 4 seismic construction
- Single point power connection

Custom requirements – we can meet most special customer requirements such as N+1 redundancies for data centers.

Fan Coils

Fan Coil Product Summary Chart

Model:

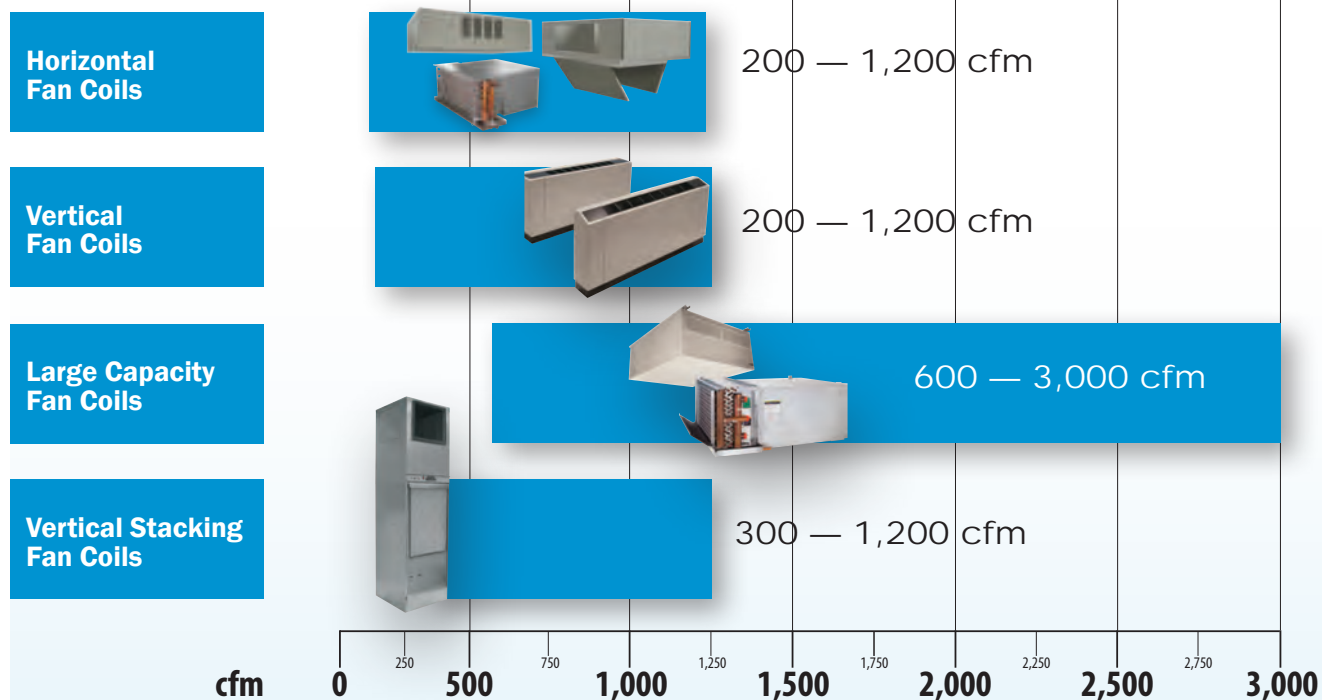

Model:

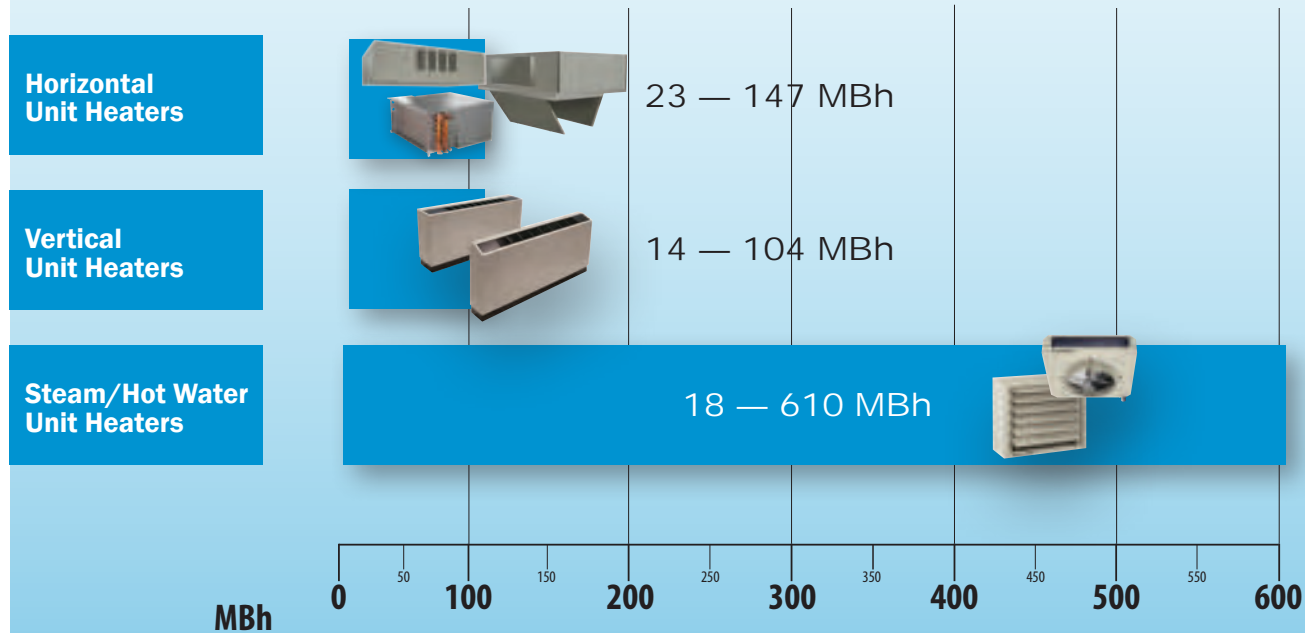

Fan Coils

Concealed Economy Ceiling Fan Coils—200 to 1,200 cfm

- Compact, lightweight design conserves space
- Coil design provides good air mixing for high thermal efficiency
- High-efficiency centrifugal fan assembly minimizes vibration and noise
- Field-flexible design for easy, low cost installation
- Service-friendly design
- Full faced, insulated plenum with rear return
- 1" supply air duct collar, removable from both sides and bottom
- 1" throwaway filter
- Units available in stock
- AHRI certified performance
- ETL and CETL safety agency approval listing
- Low-cost alternative

For more detail, refer to Catalog 700.

For the most current information, refer to DaikinApplied.com.

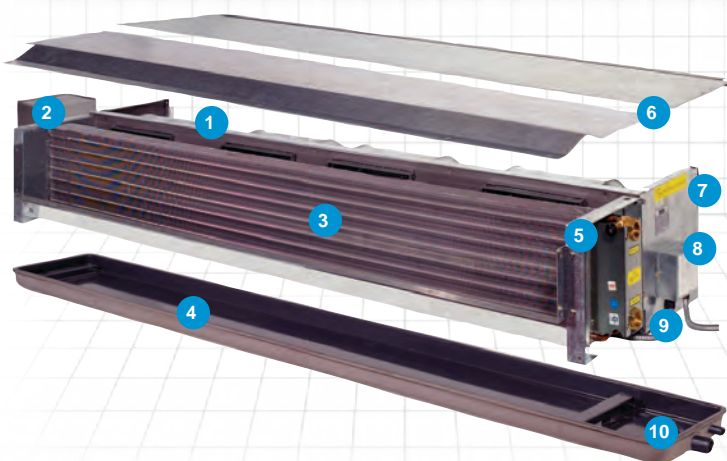

- 1 Quiet centrifugal fan assembly
- 2 LV-3SP interface control junction box (optional)
- 3 High-efficiency coil with standard protective coating
- 4 Removable, cleanable and positively sloped drain pan designed to promote good indoor air quality
- 5 Service friendly manual air vent
- 6 Top panels have foil face insulation to prevent fibers from entering airstream for high IAQ
- 7 Insulated return air plenum
- 8 Terminal box (basic)
- 9 Field-flexible piping connections
- 10 Overflow drain connection

Performance Data—FTHC Fan Coils

Model	FTHCH02		FTHCH03		FTHCH04		FTHCH06		FTHCH08		FTHCH10		FTHCH12		
	2-pipe	4-pipe	2-pipe	4-pipe	2-pipe	4-pipe	2-pipe	4-pipe	2-pipe	4-pipe	2-pipe	4-pipe	2-pipe	4-pipe	
Air flow (cfm) ³	200		300		400		600		800		1000		1200		
AHRI total cooling cap. (Btuh) ¹	8500		11,100		14,500		21,200		22,700		25,300		34,200		
AHRI sensible clog. cap. (Btuh)	6100		8400		10,800		16,100		18,000		20,000		27,000		
AHRI heating cap. (Btuh) ²	14,900	11,500	20,300	16,300	26,800	20,400	37,600	29,600	42,400	36,100	48,300	40,300	68,800	49,800	
Water flow—3-row (gpm)	1.94		2.51		3.26		4.70		5.14		5.70		7.75		
Water flow—1-row (gpm)	N/A	0.64	N/A	0.91	N/A	1.12	N/A	1.65	N/A	2.00	N/A	2.24	N/A	2.76	
Water PD—3-row (ft WC)	5.10		3.26		5.80		12.82		3.68		4.76		8.29		
Water PD—1-row (ft WC)	N/A	1.47	N/A	2.89	N/A	5.32	N/A	10.72	N/A	3.24	N/A	4.07	N/A	6.45	
Fan(s)	Centrifugal fan (forward curved galvanized steel fan wheel)														
	Type	Galvanized steel													
	Number	1		1		2		2		3		3		4	
Coil	Fan housing	Water													
	Type	Water													
	Rows ⁴	3-row	3/1-row	3-row	3/1-row	3-row	3/1-row	3-row	3/1-row	3-row	3/1-row	3-row	3/1-row	3-row	3/1-row
	Testing press.	425 psi for 1 minute; leak test: 225 psi for 5 minutes													
Motor(s)	Type	PSC													
	Number	1		1		1		1		2		2		2	
	Power supply	115/60/1, 208-230/50-60/1, 277/60/1													
Watts—high speed	50 HHBB	62		91		109		171		242		249		321	
	60 HHBB	75		109		131		205		291		299		385	
	Coil connection	3/4" FPT													
	Drain pipe	3/4" MPT													
	Ship weight (lbs.) ⁵	61.00	63.00	69.00	73.00	83.00	88.00	97.00	102.00	127.00	134.00	137.00	143.00	146.00	153.00

1. Conditions: Cooling capacity: Entering air temperature 80°F (OB), 67°F (WB); Entering water temperature 45°F, Leaving Water Temperature 55°F.

2. Heating capacity: Entering air temperature 70°F (OB); Entering water temperature 140°F, the same amount of water flow as with cooling.

3. Nominal air flow: Under dry coil conditions; Fan speed high.

4. 3-Row = 3-row chilled water/hot water coil; 4-Row = 3-row chilled water, 1-row hot water coil.

5. Weight includes return air plenum and packing.

Fan Coils

Dimensional Data—Ceiling Concealed Fan Coils

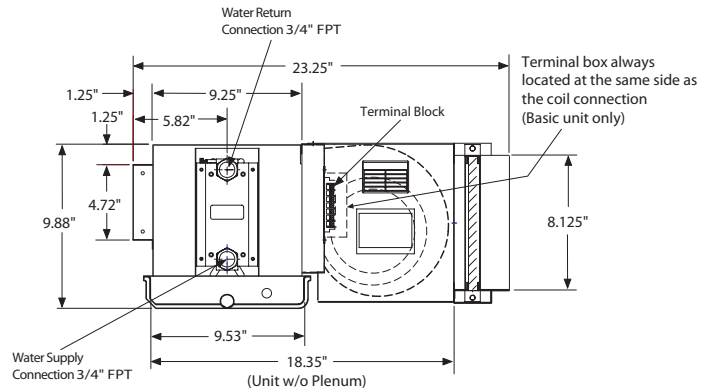
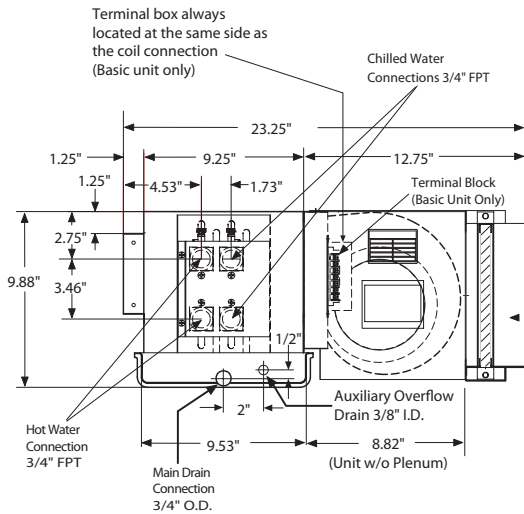
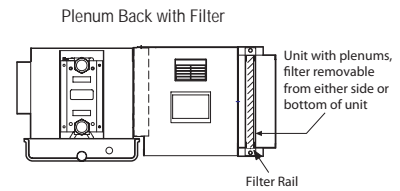
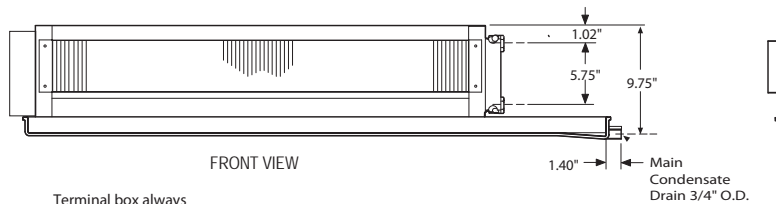
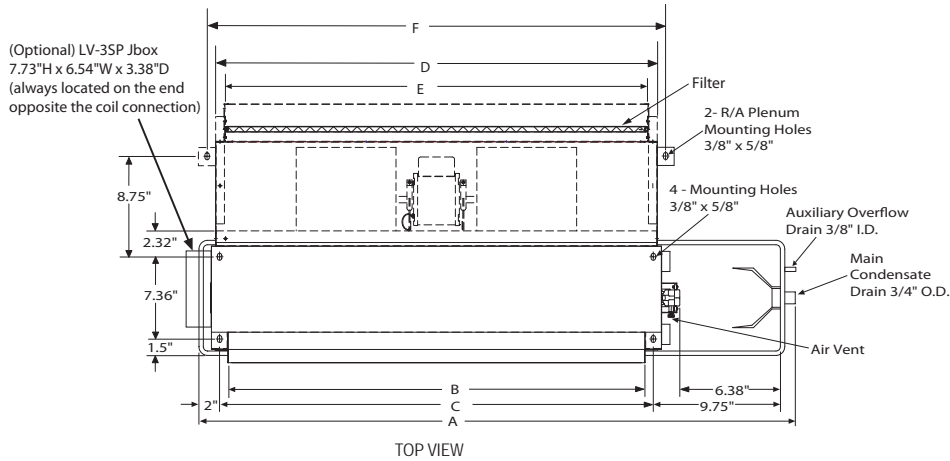

Available options:

- Two-pipe or four-pipe systems
- Low voltage junction box
- Three-speed control switch
- Wall mounted, low and high-voltage thermostats
- A variety of field installed valve packages, line or low voltage
- Stainless steel drain pan with overflow drain connection
- Condensate overflow detection kits
- Transformers
- Anticorrosion fin coil coating

Dimensional Data—FTHC Fan Coils

Model	A	B	C	D	E	Number of Fans	Filters	
							Size ¹	Qty
FTHCH02	32.05"	17.64"	19.17"	19.96"	18.46"	1	18-1/8" x 8" x 1"	1
FTHCH03	38.74"	24.33"	25.87"	26.65"	25.15"	1	24-7/8" x 8" x 1"	1
FTHCH04	43.86"	29.45"	30.98"	31.77"	30.20"	2	29-7/8" x 8" x 1"	1
FTHCH06	51.73"	37.32"	38.86"	39.65"	38.07"	2	18-7/8" x 8" x 1"	2
FTHCH08	61.57"	47.17"	48.70"	49.49"	47.91"	3	23-3/4" x 8" x 1"	2
FTHCH10	65.51"	51.10"	52.64"	53.43"	51.85"	3	25-3/4" x 8" x 1"	2
FTHCH12	75.75"	61.34"	62.87"	63.66"	62.09"	4	30-7/8" x 8" x 1"	2

1. Dimensions based on unit with return air plenum and filter.

ThinLine™ Horizontal Fan Coils—200 to 1,200 cfm

- Seven unit sizes from 200 to 1,300 cfm
- Heavy-gauge galvanized steel construction for longer life
- Fully concealed, exposed or recessed applications
- 2-pipe or 4-pipe configuration
- 2-, 3- and 4-row primary coil option
- Standard or high capacity secondary coil; reheat or preheat
- Electric heat, both total and auxiliary
- Mixing box/economizer option
- AHRI-certified performance, ETL and CETL safety agency approval listing
- Factory-installed valve packages with secondary drain pans
- Multiple control options, including MicroTech III controllers
- Fiberglass or close-cell insulation option

For more detail, refer to Catalog 724.

For the most current information, refer to DaikinApplied.com.

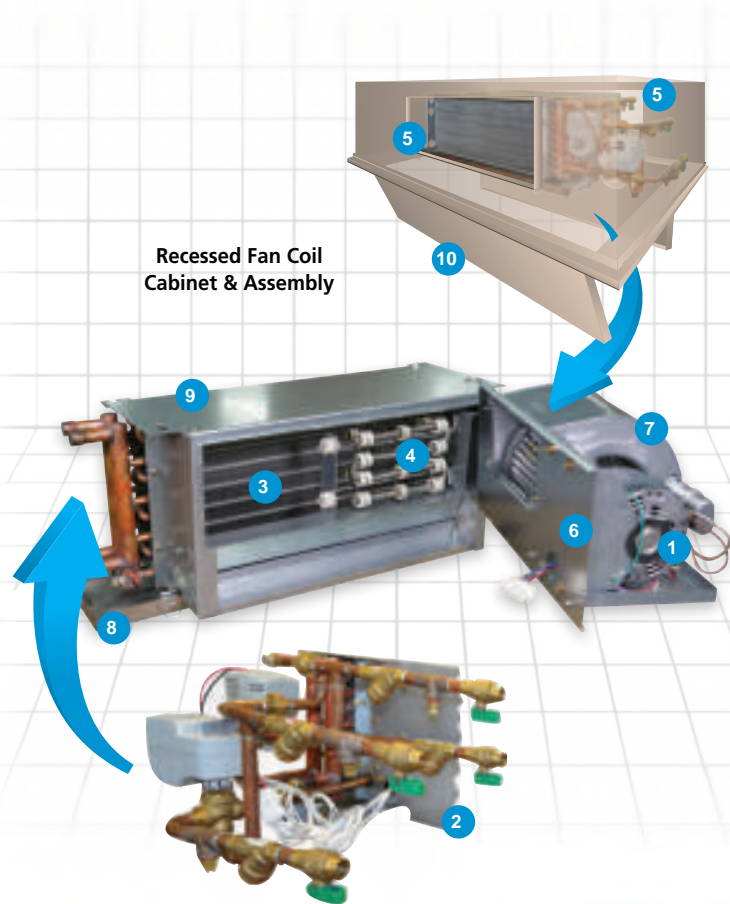

Recessed Fan Coil Cabinet & Assembly

- 1 3-Speed PSC or ECM motor(s)
- 2 Software selectable/factory-installed valve packages
- 3 Primary (2, 3, 4-row) and secondary coils (preheat or reheat)
- 4 Total or auxiliary electric heat
- 5 Front/bottom discharge, bottom/rear return configurations
- 6 Easily removable fan deck/drain pan(s)
- 7 Quiet forward curved blower(s)
- 8 Galvanized or ss primary and secondary drain pan
- 9 Heavy-gauge galvanized steel construction
- 10 Large access doors (exposed/recessed units)

Available options:

- MicroTech controller
- Low-voltage/line-voltage control packages
- Multiple filters including MERV13
- Multiple capacity steam or hot water coil
- Choice of 5 cabinet colors



Exposed ceiling unit



Recessed ceiling unit



Hideaway unit

Fan Coils

Performance Data—ThinLine Horizontal Fan Coils

Cooling and Heating Performance: Standard Rating 2-Pipe

Unit Model	Unit Size	Nominal Air Flow SCFM	Number of Primary Rows	Cooling Performance		Heating Performance MBH	Chilled Water Flow gpm	CW Pressure Drop ft
				Total, MBH	Sensible, MBH			
FCHH	02	200	3	8.9	7.0	28.1	1.8	1.0
	03	300	3	10.7	8.5	32.9	2.2	1.3
	04	400	3	13.9	10.6	40.5	2.8	2.4
	06	600	3	20.4	15.4	63.8	4.1	6.1
	08	800	3	23.6	17.6	71.4	4.7	8.4
	10	1000	3	34.7	26.1	100.6	7.0	13.5
	12	1200	3	45.2	33.7	124.1	9.1	26.6
FCHC	02	200	3	8.5	6.7	27.1	1.7	0.9
	03	300	3	10.6	8.3	32.5	2.1	1.3
	04	400	3	13.4	10.2	39.2	2.7	2.3
	06	600	3	19.7	14.9	61.6	4.0	5.8
	08	800	3	21.5	15.8	64.2	4.3	7.2
	10	1000	3	30.8	22.8	88.4	6.1	9.9
	12	1200	3	39.5	28.9	107.2	7.9	19.6

Cooling: EAT (WB/DB) = 80°F/67°F; EWT/LWT = 45°F/55°F; Heating: EAT=70; EWT/LWT=180°F/150°F
 Hideaway unit without plenum at 0.05" ESP;
 Cabinet unit with 1" Throwaway filter, bottom return / front discharge configuration at 0" ESP

Cooling and Heating Performance: Standard Rating 4-Pipe

Unit Model	Unit Size	Nominal Air Flow SCFM	Number of Primary Rows	Cooling Performance				Heating Performance			
				Total, MBH	Sensible, MBH	Chilled Water Flow gpm	CW Pressure Drop, ft	Standard Capacity Coil, MBH	High Capacity Coil, MBH	Hot Water Flow (Hi Cap), gpm	Hot Water Pressure Drop (Hi Cap), ft
FCHH	02	200	3	8.3	6.5	1.7	0.9	8.1	11.6	0.8	1.6
	03	300	3	10.1	8.0	2.0	1.2	8.8	12.7	0.9	1.9
	04	400	3	13.1	10.0	2.6	2.2	12.2	19.1	1.3	5.3
	06	600	3	19.4	14.6	3.9	5.6	18.6	27.8	1.9	12.6
	08	800	3	22.5	16.6	4.5	7.7	21.0	31.9	2.1	16.8
	10	1000	3	33.1	24.7	6.6	12.0	33.7	42.9	2.9	36.2
	12	1200	3	43.0	31.8	8.6	23.2	40.5	57.8	3.9	71.1

Hideaway unit without plenum at 0.05" ESP; 115/1/60 PSC motor at High speed setting
 Free discharge
 Cooling: EAT (WB/DB) = 80°F/67°F; EWT/LWT = 45°F/55°F; dry coil Heating: EAT=70; EWT/LWT=180°F/150°F

Units with ECM Cooling and Heating Performance 2- & 4-Pipe

Unit Model	Unit Size	Air Flow SCFM	Number of Primary Rows	Cooling Performance		Heating Performance		
				Total, MBH	Sensible, MBH	Primary Coil, MBH	Secondary Std Capacity Coil, MBH	Secondary High Capacity Coil, MBH
FCHH, FCHC, FCHR any configuration	02	329	3	9.6	7.5	28.6	8.4	12.2
	03	393	3	11.1	8.8	32.7	8.9	13.1
	04	459	3	14.6	11.3	41.1	12.6	19.9
	06	704	3	21.5	16.4	65.3	19.2	29.1
	08	755	3	24.5	18.3	71.2	21.3	32.9
	10	1124	3	36.0	27.2	101.2	34.4	44.4
	12	1464	3	47.5	35.7	126.4	41.6	60.2

ECM motor at High speed setting, any external static pressure up to 0.5"
 Unit of any configuration with standard throwaway (MERV 4) filter
 Cooling: EAT (WB/DB) = 80°F/67°F; EWT/LWT = 45°F/55°F; Heating: EAT=70; EWT/LWT=180°F/150°F

The ratings above are shown for 3-row primary coil only. For other coil configurations, refer to Catalog 724 or Daikin Tools selection software.

Fan Coils

Dimensional Data

Hideaway fan coil, front discharge – free return

Reheat coil shown

Top View

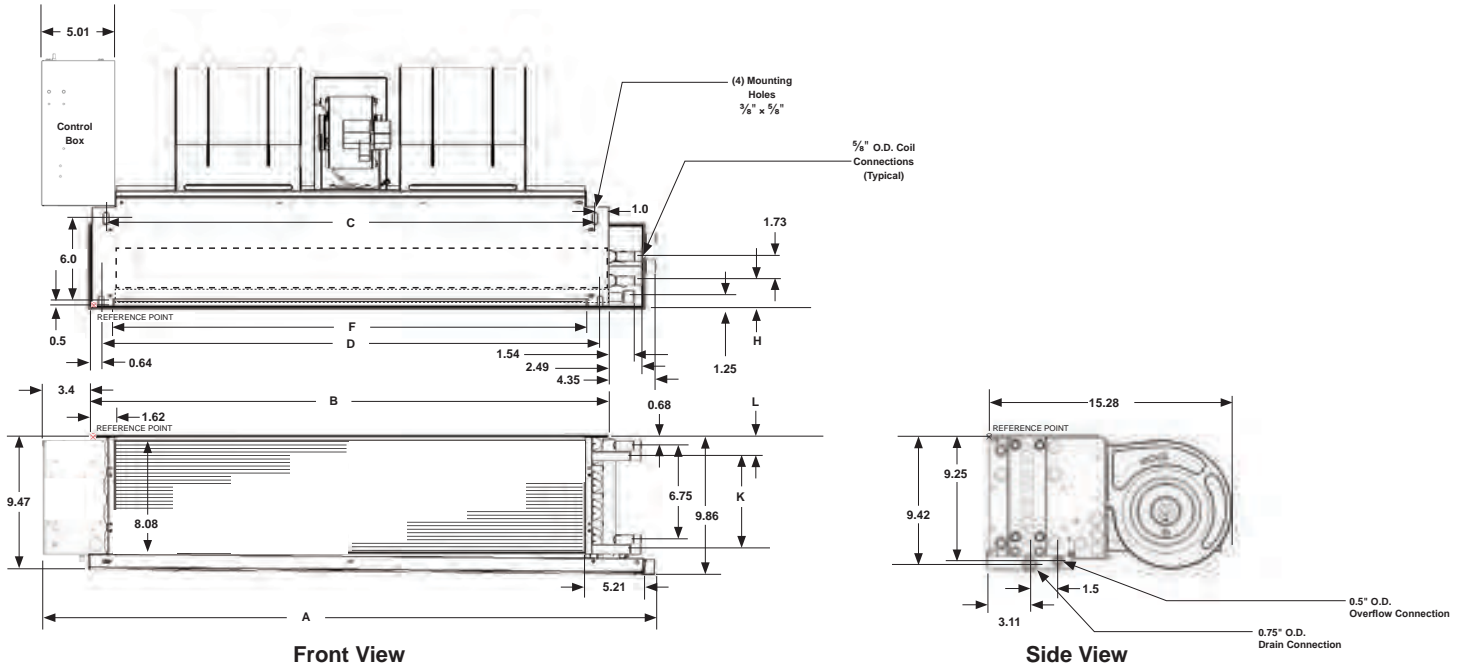

Fan Coils

Dimension		S02	S03	S04	S06	S08	S10	S12
		inch (mm)	inch (mm)	inch (mm)	inch (mm)	inch (mm)	inch (mm)	inch (mm)
Overall Unit Width	A	28.48 (723)	28.48 (723)	33.98 (863)	44.98 (1142)	50.48 (1282)	61.48 (1562)	72.48 (1841)
Chassis Width	B	20.63 (524)	20.63 (524)	26.13 (664)	37.13 (943)	42.63 (1083)	53.63 (1362)	64.63 (1641)
Mounting Hole Distance (Rear)	C	18.64 (473)	18.64 (473)	24.14 (613)	35.14 (892)	40.64 (1032)	51.64 (1312)	62.44 (1702)
Mounting Slot Location (Front)	D	19.35 (491)	19.35 (491)	24.85 (631)	35.85 (911)	41.35 (1050)	52.35 (1330)	63.35 (1609)
Discharge Opening - Width	F	17.39 (442)	17.39 (442)	22.84 (581)	33.89 (867)	39.39 (1000)	50.39 (1280)	61.39 (1559)
Primary Coil Location	H	1.81 (46) for 2- or 3-row primary coil; 2.81 (71) for 4-row primary coil						
Secondary Coil - Standard Capacity	L	2.86 (73)						
Secondary Coil - High Capacity		0.86 (22)						
Secondary Coil - Standard Capacity	K	5.0 (127)						
Secondary Coil - High Capacity		7.0 (178)						

Fan Coils

Dimensional Data

Cabinet fan coil, front discharge – rear return

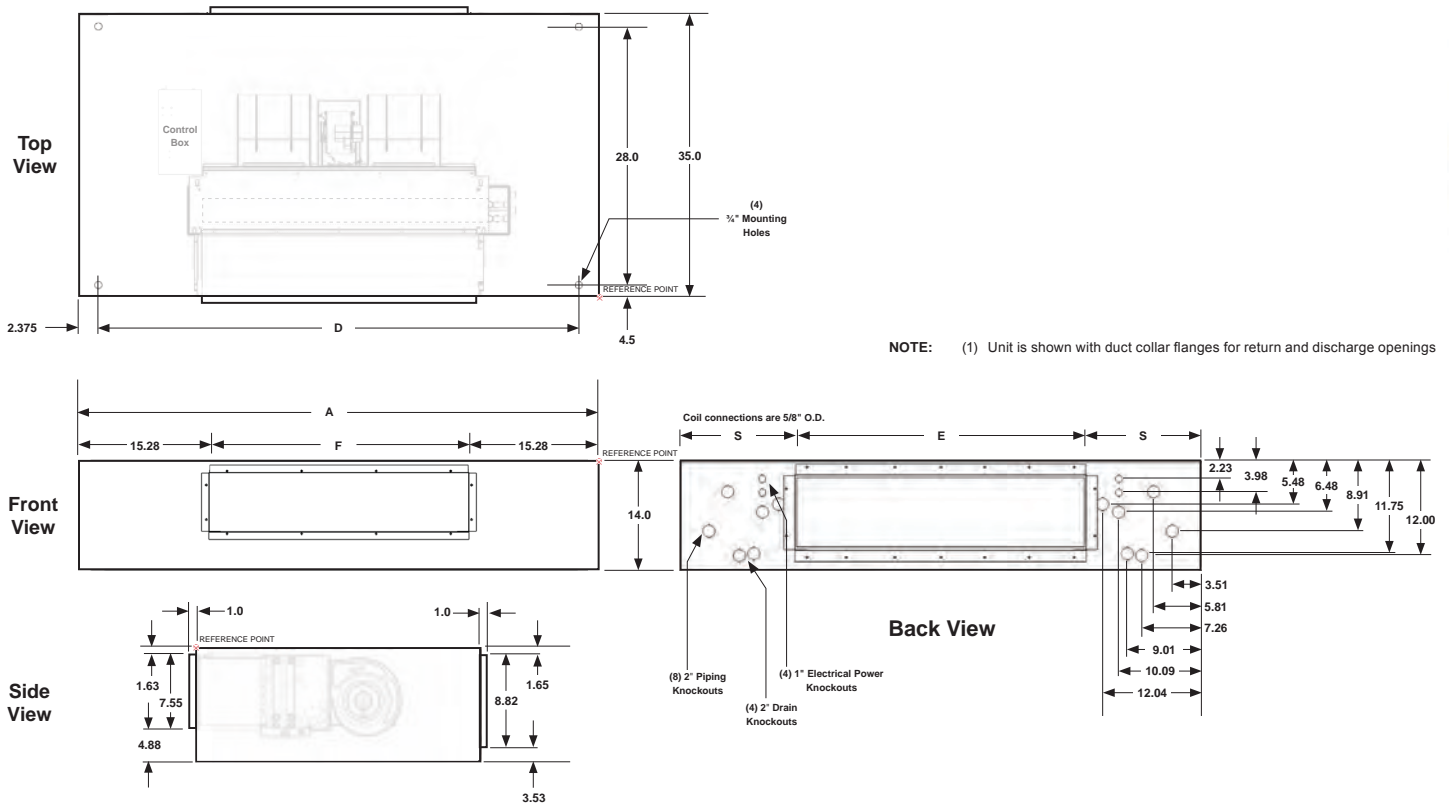

Dimension		S02	S03	S04	S06	S08	S10	S12
		inch (mm)	inch (mm)	inch (mm)	inch (mm)	inch (mm)	inch (mm)	inch (mm)
Overall Unit Width	A	47.64 (1210)	47.64 (1210)	53.14 (1350)	64.14 (1629)	69.64 (1769)	80.63 (2048)	91.64 (2328)
Mounting Hole Distance	D	40.64 (1032)	40.64 (1032)	46.14 (1172)	57.14 (1451)	62.64 (1591)	73.64 (1870)	84.64 (2150)
Return Air Opening - Width	E	19.0 (483)	19.0 (483)	22.9 (581)	34.5 (876)	38.4 (975)	50.0 (1270)	61.6 (1565)
Discharge Opening - Width	F	17.09 (434)	17.09 (434)	22.59 (574)	33.59 (853)	39.09 (993)	50.09 (1272)	61.09 (1552)
Return Air Opening Location	S	14.32 (364)	14.32 (364)	15.13 (384)	14.82 (376)	15.63 (397)	15.32 (389)	15.01 (381)

ThinLine™ Vertical Fan Coils—200 to 1,200 cfm

- Seven unit sizes from 200 to 1,200 cfm
- 2-pipe or 4-pipe configurations
- Heavy-gauge galvanized steel construction for longer life
- Closed-cell insulation standard
- Electric heat, total or auxiliary
- Fully concealed, exposed or recessed applications
- AHRI certified performance
- ETL and CETL safety agency approval listing

For more detail, refer to Catalog 722.

For the most current information, refer to DaikinApplied.com.

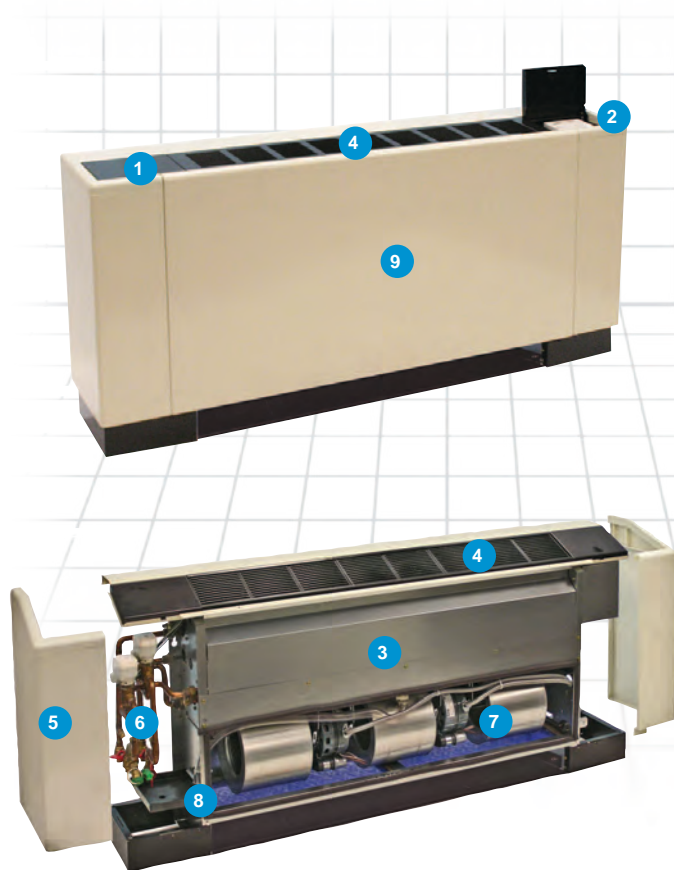

- Configuration options**
 - Flat Top
 - Sloped Top
 - Hideaway
 - Control options**
 - 3-speed switch or low voltage interface board
 - Analog or digital thermostat
 - Remote or unit mounted
 - 3-speed or staged fan control
 - Coil options**
 - 2, 3, or 4-row main coil
 - 1 or 2-row preheat or 1-row reheat coil
 - Hot water or steam
 - Same or opposite end connections
 - Grille options**
 - Stamped or multi-directional outlet grilles
 - Return grille option
 - Extended end pockets**
 - 4" each side
 - 8" one side
 - Diverse, flexible valve and piping packages**
 - Software selectable factory-mounted, wired, and tested, or
 - Factory-assembled and shipped loose for field-mounting
 - Normally closed or open, on/off or modulating valves
 - Easily removed drain pan and motor assembly**
 - For easy maintenance and service
 - Sloped, polymer drain pan for good IAQ
 - Optional secondary drain pan**
 - Noncorrosive plastic or stainless steel option
 - Easily removed
 - Cabinet color options**
 - Antique Ivory
 - Cupola White
 - Soft Gray
 - Off-White
 - Putty Beige
- Electric heat options:**
- Singlepoint power connections
 - Total or auxiliary heat

Cooling and Heating Performance—Two-Pipe Systems

Unit Size	Main Coil Rows	SCFM	Cooling Performance				Heating Performance	
			Total MBh (kW)	Sensible MBh (kW)	Gpm (L/s)	WPD ft of H ₂ O (kPa)	MBh (kW)	Gpm (L/s)
02	4 Row	200	5.9 (1.7)	4.7 (1.4)	1.2 (0.08)	0.6 (1.8)	19.2 (5.6)	1.2 (0.08)
03	4 Row	265	9.4 (2.8)	6.9 (2.0)	1.9 (0.12)	1.5 (4.5)	27.2 (8.0)	1.9 (0.12)
04	4 Row	374	14.3 (4.2)	10.2 (3.0)	2.9 (0.18)	3.4 (10.2)	38.9 (11.4)	2.9 (0.18)
06	4 Row	554	22.4 (6.6)	15.2 (4.5)	4.6 (0.29)	9.0 (26.9)	52.6 (15.4)	4.6 (0.29)
08	4 Row	634	26.4 (7.7)	17.8 (5.2)	5.5 (0.35)	14.8 (44.2)	64.3 (18.8)	5.5 (0.35)
10	4 Row	795	32.4 (9.5)	21.9 (6.4)	6.7 (0.42)	11.1 (33.2)	80.8 (23.7)	6.7 (0.42)
12	4 Row	1022	40.2 (11.8)	27.0 (7.9)	8.3 (0.52)	18.3 (54.7)	103.8 (30.4)	8.3 (0.52)

* Rated in accordance with AHRI Standard 440. Cooling performance is based on 80/67°F (27/19°C) entering air temperature, 45°F (7°C) entering chilled water temperature with a 10°F (5.5°C) ΔT. Heating performance is based on 70°F (21°C) entering air temperature, 180°F (82°C) entering hot water temperature with a 30°F (17°C) ΔT

* Ratings shown are for 2-pipe systems with 4-row coil. For ratings with 4-pipe systems and other coil configurations, consult catalog 722.

Fan Coils

Performance Data—Unit Dimensions

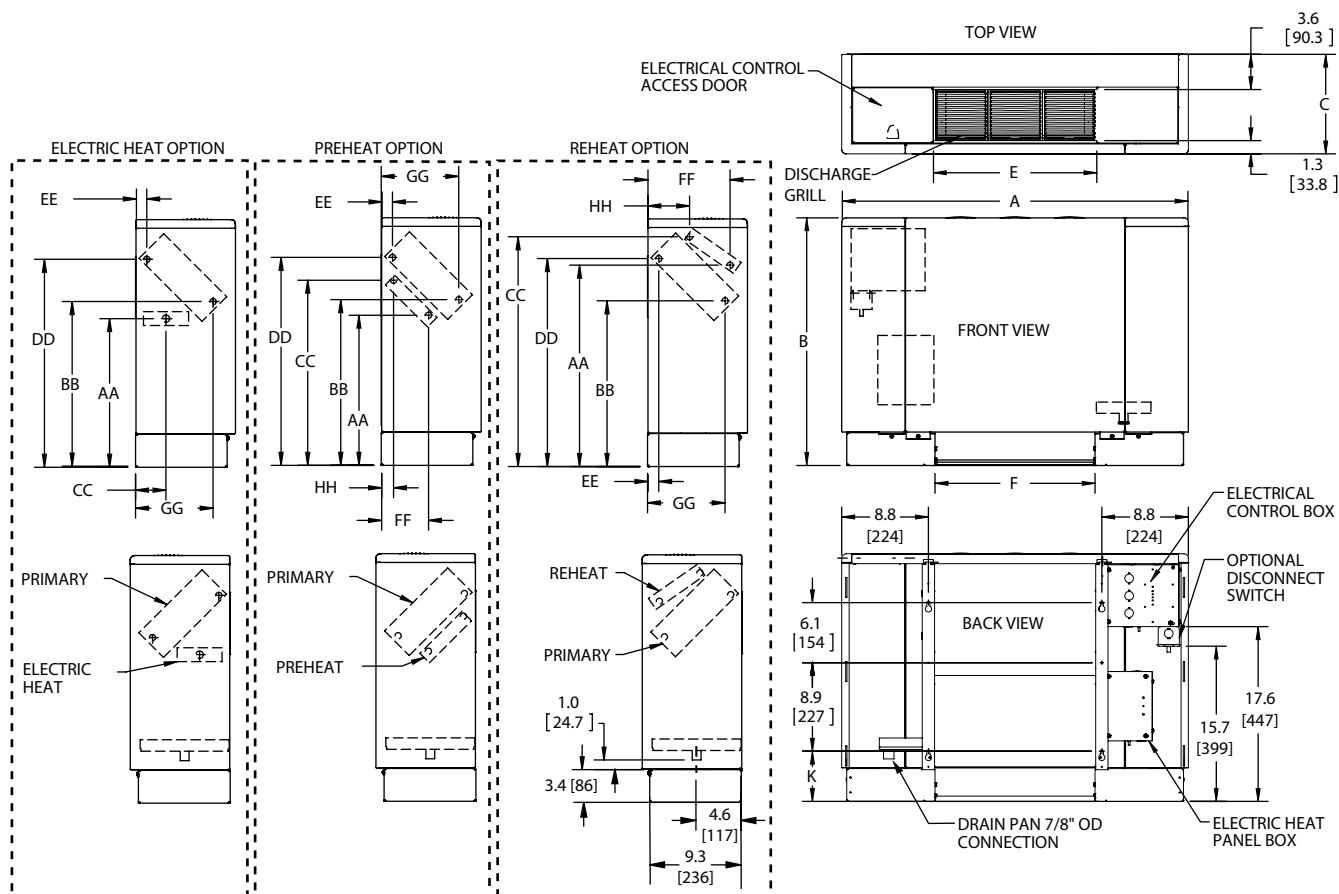

Dimension		S02		S03		S04		S06		S08		S10		S12	
		inch	mm	inch	mm	inch	mm	inch	mm	inch	mm	inch	mm	inch	mm
Unit Width	A	35.0	889	40.5	1029	46.0	1168	57.0	1448	62.5	1588	73.5	1867	84.5	2146
Unit Height	B	25.0	635	25.0	635	25.0	635	25.0	635	25.0	635	25.0	635	25.0	635
Unit Depth	C	10.0	254	10.0	254	10.0	254	10.0	254	10.0	254	10.0	254	10.0	254
Discharge Grille - Width	E	16.3	414	21.8	554	27.3	693	38.3	973	43.8	1113	54.8	1392	65.8	1671
Return Air Opening - Width	F	16.2	411	21.7	551	27.2	691	38.2	970	43.7	1110	54.7	1389	65.7	1669
Primary Coil - Water Supply	BB	16.7	424	16.7	424	16.7	424	16.7	424	16.7	424	16.7	424	16.7	424
	GG	7.8	198	7.8	198	7.8	198	7.8	198	7.8	198	7.8	198	7.8	198
Primary Coil - Water Return	DD	21	533	21	533	21	533	21	533	21	533	21	533	21	533
	EE	1.1	28	1.1	28	1.1	28	1.1	28	1.1	28	1.1	28	1.1	28
Preheat Coil - Water Return	CC	18.7	475	18.7	475	18.7	475	18.7	475	18.7	475	18.7	475	18.7	475
	HH	1.2	30	1.2	30	1.2	30	1.2	30	1.2	30	1.2	30	1.2	30
Preheat Coil - Water Supply	AA	15	381	15	381	15	381	15	381	15	381	15	381	15	381
	FF	4.7	119	4.7	119	4.7	119	4.7	119	4.7	119	4.7	119	4.7	119
Reheat Coil - Water Return	CC	23.2	589	23.2	589	23.2	589	23.2	589	23.2	589	23.2	589	23.2	589
	HH	4.2	107	4.2	107	4.2	107	4.2	107	4.2	107	4.2	107	4.2	107
Reheat Coil - Water Supply	AA	20.3	516	20.3	516	20.3	516	20.3	516	20.3	516	20.3	516	20.3	516
	FF	8.3	211	8.3	211	8.3	211	8.3	211	8.3	211	8.3	211	8.3	211
Electric Heat Connection	AA	15.1	384	15.1	384	15.1	384	15.1	384	15.1	384	15.1	384	15.1	384
	CC	3.0	76	3.0	76	3.0	76	3.0	76	3.0	76	3.0	76	3.0	76

HiLine™ Vertical Stacking Fan Coils—300 to 1,200 cfm

- Four unit sizes from 300 to 800 cfm, blow-through configuration
- Two unit sizes, 1,000 and 1,200 cfm, draw-through configuration
- Low cfm design for individual rooms
- Quiet operation
- AHRI certified performance

For more detail, refer to Catalog 770.

For the most current information, refer to DaikinApplied.com.

Low sound level operation

- Quiet, energy efficient motor and fan assembly within a fully insulated cabinet

Twin units

- Two adjacent room units can be connected to a single set of risers and still retain individual room temperature control

Fast and simple installation

- Installs by stacking one unit above another
- Unique couplings require only one person for setting and connecting

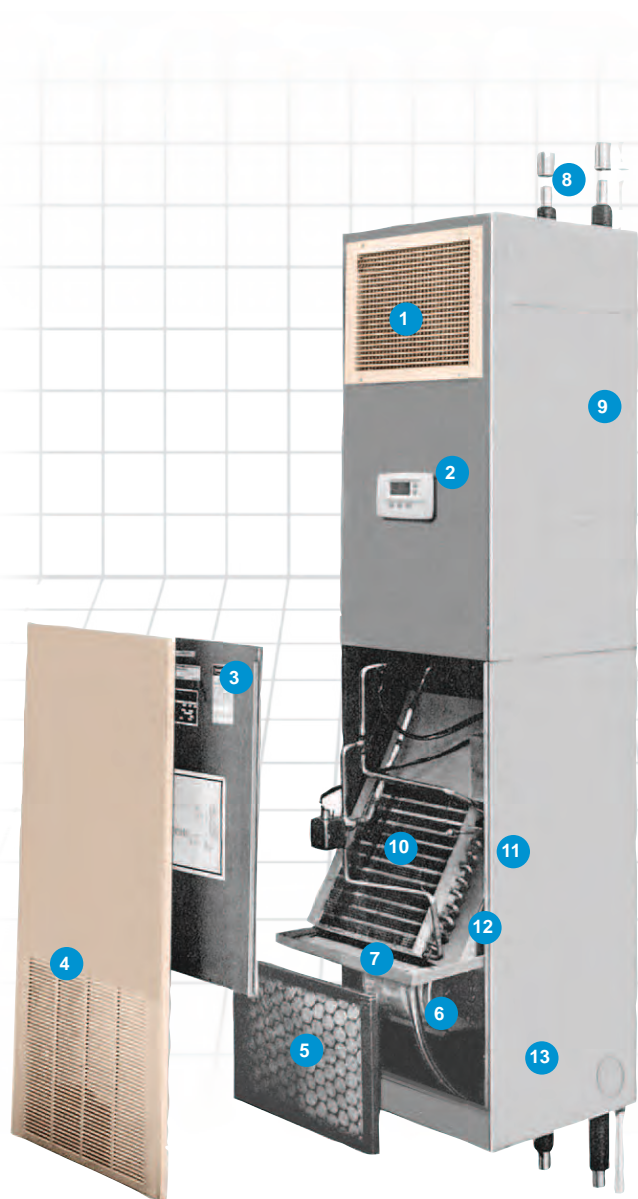

- 1 Discharge arrangements**
 - Single, double, triple and top discharge arrangements
- 2 Controls**
 - Face-mounted or remote thermostat
- 3 Access and sound baffle**
 - Insulated galvanized steel
 - Easily removed for complete access
 - Reduces sound level
- 4 Return air grille panel**
 - Heavy gauge steel with stamped grille and attractive finish
- 5 Filter**
 - Easily accessible by simple removal of air grille panel
- 6 Motor and fan assembly**
 - Energy efficient and quiet
 - Fan motor is easily removed
 - ECM motor option available
- 7 Drain pan options**
 - Galvanized (standard)
 - Stainless steel
 - Overflow detection
- 8 Risers**
 - Risers from 100–115" long. No on-the-job cutting required. Supply and return risers are factory insulated and have sweat ball valves (union ball valve combination optional)
- 9 Cabinet**
 - Heavy gauge galvanized steel
 - Fully insulated
 - Aluminum foil face or closed cell insulation available
- 10 Coils**
 - High efficiency type
 - AHRI certified performance
- 11 Valve packages**
 - Low-voltage or line-voltage
 - Factory installed or field mounted preassembled kits
- 12 Removable chassis**
 - All components mounted on a single removable chassis
 - Different capacity chassis can be installed in the future if required
- 13 Fresh air damper**
 - Two-position
 - Motorized or manual

Note: Picture above is for 300 to 800 cfm only.

Fan Coils

Performance Data—HiLine Vertical Stacking Fan Coils

AHRI Certified Standard Ratings

Standard coil water cooling capacity ratings.¹ Capacity rating details available in Catalog 770.

Unit size	Cooling capacity ²		Water flow (gpm)	Water flow p.d. ft. w.c.
	Total Btuh	Sensible Btuh		
S03	10,500	7,200	2.0	14.6
S04	17,000	11,400	3.5	44.7
S06	22,200	14,200	4.6	28.8
S08	28,800	20,180	5.7	44.1
S10	39,600	26,600	7.9	29.7
S12	44,900	30,400	8.9	39.6

1. Rated in accordance with AHRI Standard 440. Cooling capacities based on 80°F DB/67°F WB entering air, 45°F entering water, 10°F water temperature rise and high fan speed with standard 115/60/1 motor.

2. For cooling coil capacity ratings at conditions other than those listed, consult your Daikin representative. Riser sizes available from 3/4" to 2 1/2".

Dimensional Data—sizes 03 to 08

Right hand unit shown. Hand of unit determined by facing return air opening.

Risers on right = Right hand of unit; Risers on left = Left hand of unit; Risers on back = Neutral unit.

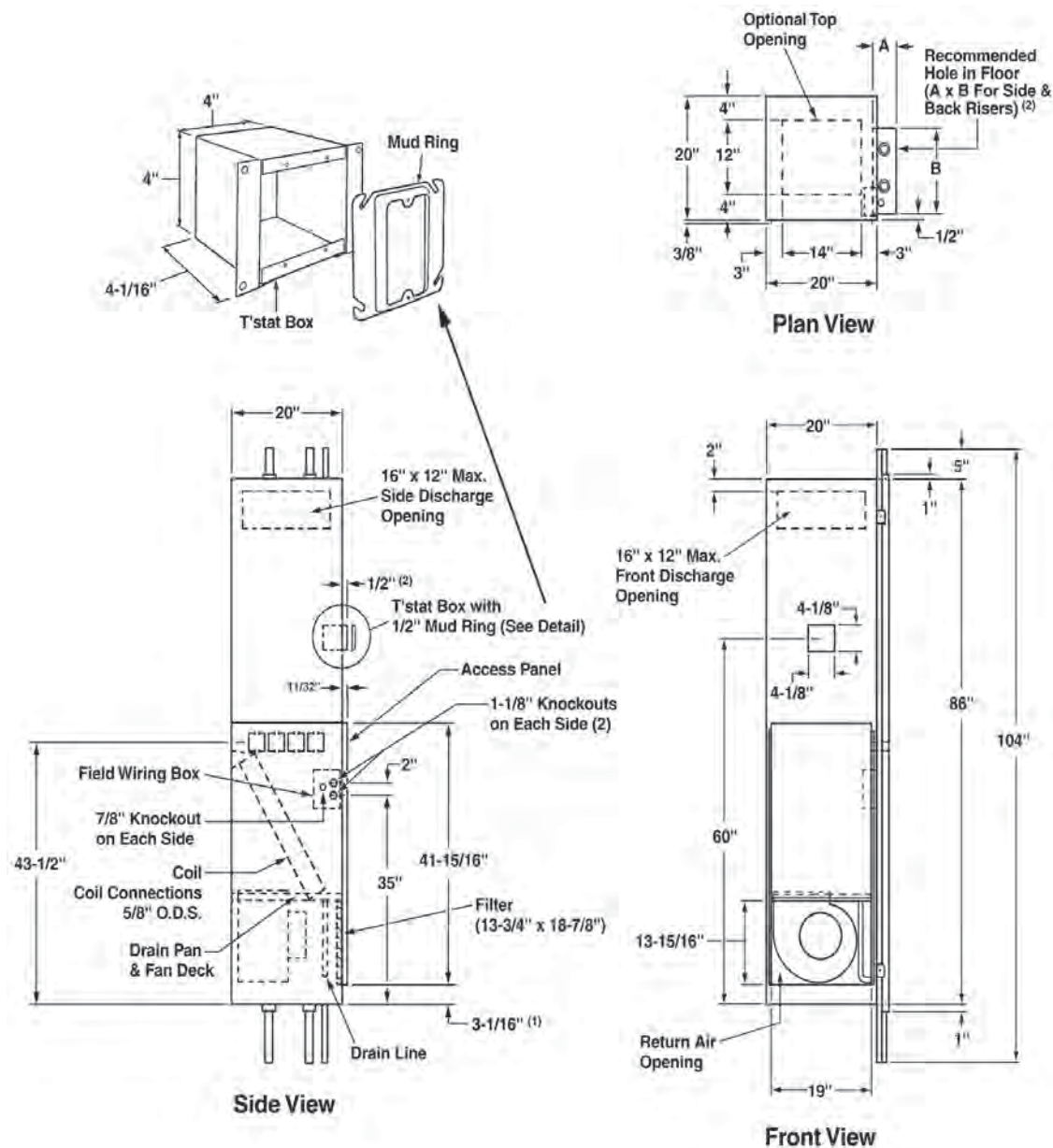

Large Capacity Fan Coils—600 to 3,000 cfm

- Five direct drive hideaway or cabinet ceiling unit sizes from 600 to 2,000 cfm
- Five belt drive hideaway or cabinet ceiling unit sizes from 800 to 3,000 cfm
- 3-row to 6-row primary coil; 1-row or 2-row secondary heating coil
- Heavy-gauge, galvanized steel construction for longer life
- UL listing

For more detail, refer to Catalog 735.

For the most current information, refer to DaikinApplied.com.

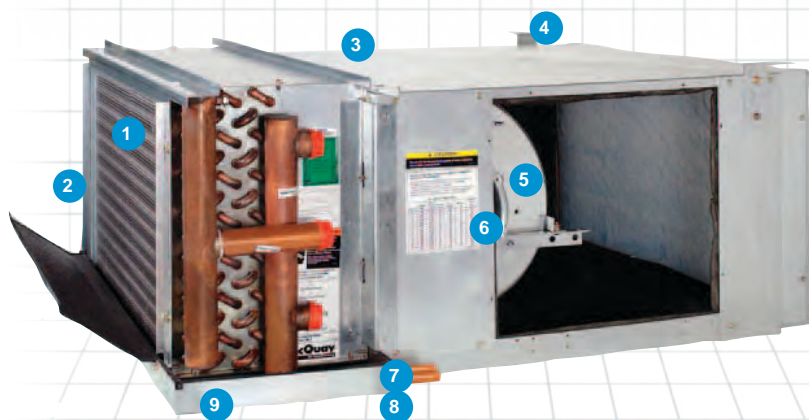

- 1 Vertically-mounted copper tube, aluminum fin coil
- 2 Discharge duct collar
- 3 Heavy-gauge galvanized steel construction with 1" neoprene coated glass fiber insulation
- 4 Full-size mounting slots in heavy-gauge hangers
- 5 Large diameter fan wheels and housings
- 6 Multi-speed PSC motor
- 7 3/4" O.D. copper overflow drain connection (optional, standard with stainless steel pan)
- 8 7/8" O.D. copper drain connection
- 9 Full width insulated drain pan, available in galvanized or stainless steel with overflow drain connection

Available options:

- Stainless steel drain pan with overflow drain connection
- Deluxe valve package low or high-voltage for field mounting
- 1 or 2-row hot water or steam coils (preheat position)
- Condensate overflow detection kits
- Disconnect and/or low voltage-3 speed junction box

Direct drive hideaway unit

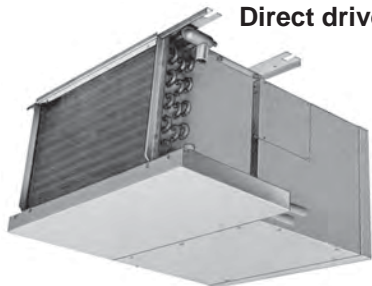

Direct drive cabinet ceiling unit



Fan Coils

Performance Data—Large Capacity Fan Coils, Direct Drive

Standard Coil Water Cooling Capacity Ratings¹

High capacity and heating capacity detail is available in Catalog 720.

Unit types	Size	Cooling capacity ²		Water flow (gpm)	Water flow p.d. (ft. w.c.)
		Total Btuh	Sensible Btuh		
HCDB, HHDB	S06	17,600	14,500	3.5	3.7
HCDB, HHDB	S08	26,000	19,700	5.2	3.5
HCDB, HHDB	S12	37,000	26,800	7.4	8.1
HCDB, HHDB	S16	53,000	40,000	10.6	3.2
HCDB, HHDB	S20	61,000	48,000	12.2	3.2

1. Cooling capacities based on 80°F DB/67°F WB entering air, 45°F entering water, 10°F water temperature rise in HHDB unit with plenum operating at high fan speed with no external static pressure.

2. For cooling coil capacity ratings at conditions other than those listed, consult your Daikin representative.

Performance Data—Large Capacity Fan Coils, Belt Drive

Standard Coil Water Cooling Capacity Ratings¹

Unit types	Size	Airflow (cfm)	Cooling capacity ²		Water flow (gpm)	Water flow p.d.(ft. w.c.)
			Total Btuh	Sensible Btuh		
Cabinet and hideaway	S08	800	24,000	17,700	4.8	3.1
		900	25,615	19,241	5.1	3.4
	S12	1200	37,265	27,027	7.5	8.2
		1300	38,898	28,581	7.8	8.8
	S16	1600	48,421	35,472	9.7	2.7
		1800	51,521	38,482	10.3	3.0
	S20	2000	57,596	45,014	11.5	2.9
		2200	60,565	48,102	12.1	3.1
	S30	3000	91,633	66,864	18.3	2.9
		3200	94,813	69,923	19.0	3.1

1. Cooling capacities based on 80°F DB/67°F WB entering air, 45°F entering water, 10°F water temperature rise.

2. For cooling coil capacity ratings at conditions other than those listed, consult your Daikin representative.

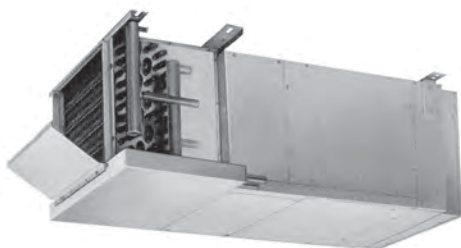

Belt drive hideaway unit



Belt drive cabinet ceiling unit

Fan Coils

Dimensional Data—Large Capacity Fan Coils, Cabinet, Direct-Drive

Right-hand unit shown. (Hand of unit determined by cooling unit connection *when facing discharge*.)

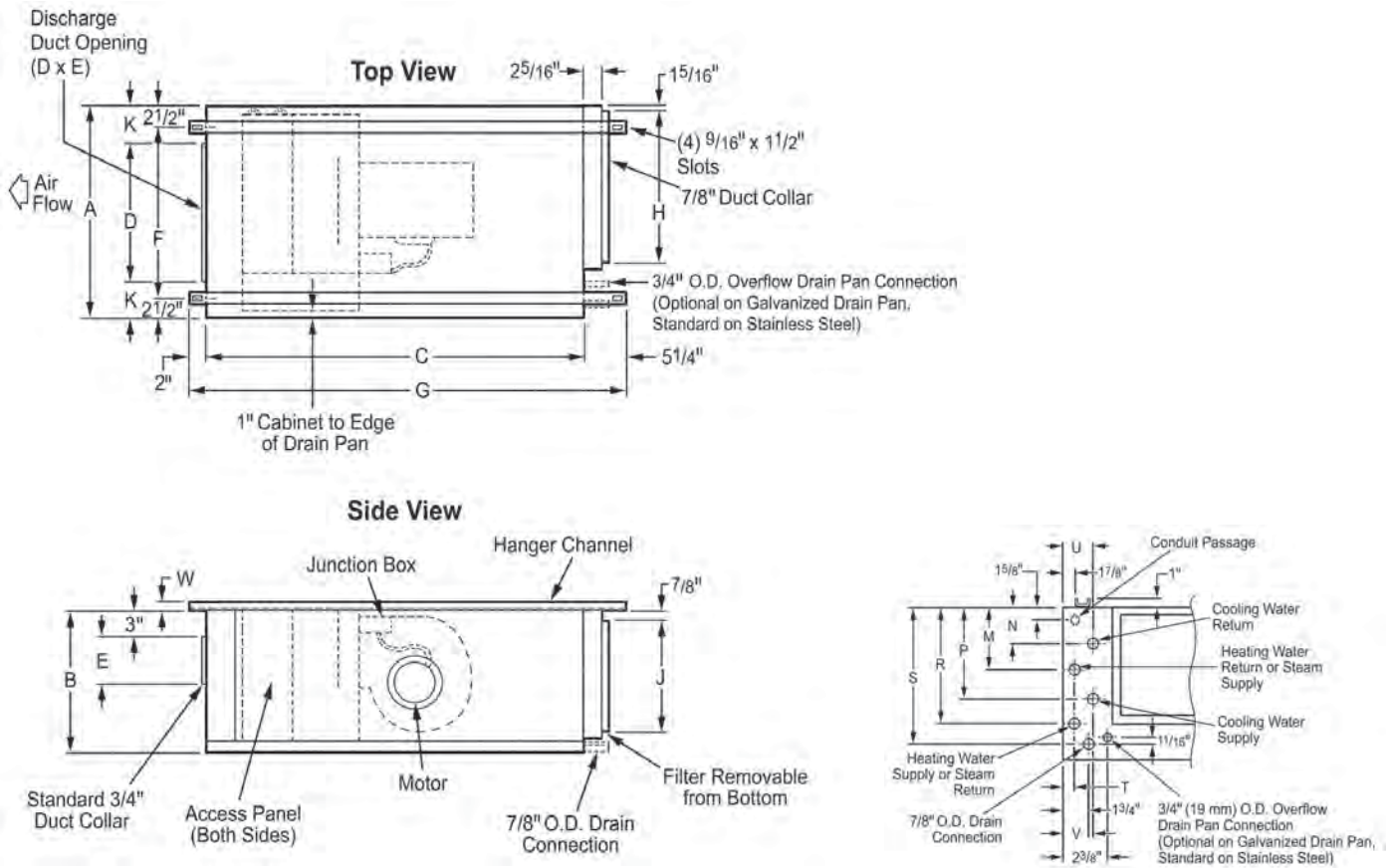

HCDB model	Unit dimensions (in) ¹																		
	A	B	C	D	E	F	G	H	J	K	M	N	P	R	S	T	U	V	W
S06	24	17-5/8	37	20	4	19	44-1/4	18-1/2	14-5/8	2	4-7/16	2-11/16	9-9/16	11-3/8	14-1/4	1-9/16	1-9/16	1-9/16	1
S08	26	17-5/8	46	20	6	21	53-1/4	18-1/2	14-5/8	3	4-7/16	4-7/16	12-1/16	13-7/8	16-3/4	1-9/16	1-9/16	3-3/4	1
S12	33	17-5/8	46	24	8	28	53-1/4	23-1/2	14-5/8	4-1/2	4-7/16	4-7/16	12-1/16	13-7/8	16-3/4	1-9/16	1-9/16	3-3/4	1
S16	44	17-5/8	46	36	8	39	53-1/4	38-1/2	14-5/8	4	4-7/16	4-7/16	8-3/16	13-3/4	16-3/4	2-1/4	2-1/4	2-1/4	1
S20	46	21-1/8	50	41-3/4	6	41	57-1/4	38-1/2	18-5/8	2-1/8	5-1/16	4-1/8	9-7/16	16-1/4	19-1/4	2-1/4	4-3/16	4-3/16	1-1/4

1. All dimensions approximate. Certified drawings available upon request.

Fan Coils

Dimensional Data—Large Capacity Fan Coils, Hideaway, Direct-Drive

Right-hand unit shown. (Hand of unit determined by cooling unit connection *when facing discharge*.)

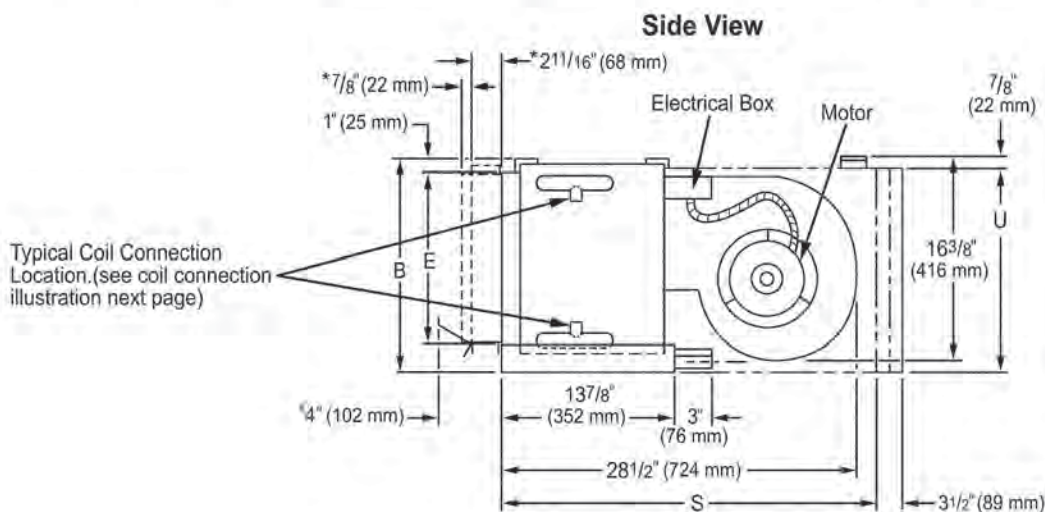
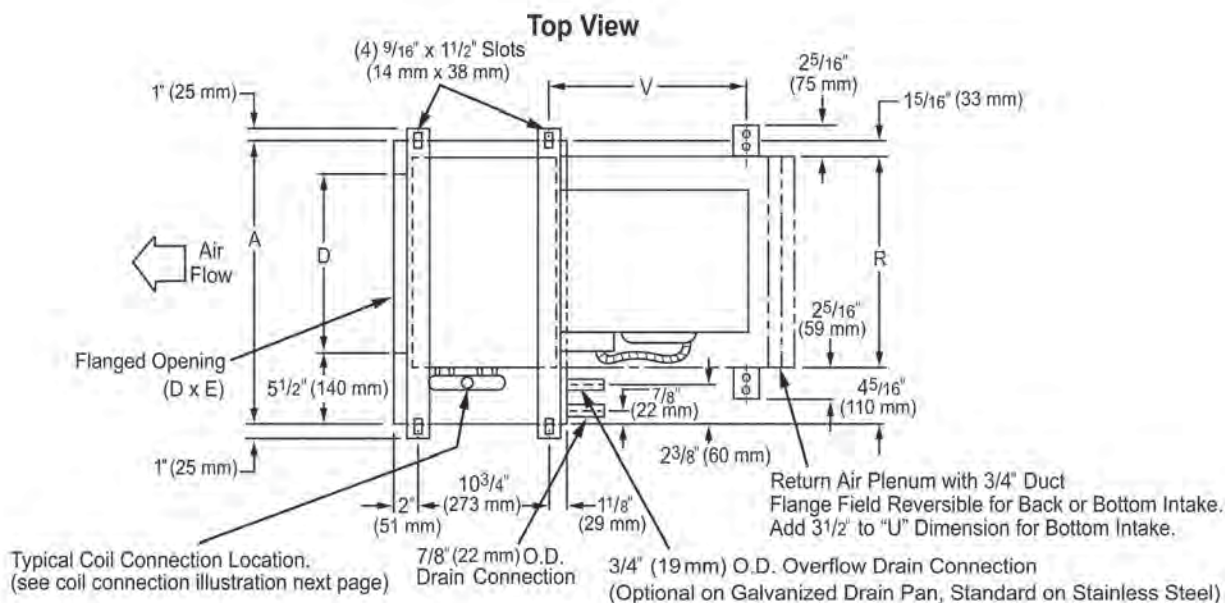

HHDB model	Unit dimensions (in) ¹							
	A	B	D	E	R	S	U	V
S06	22	14	14	10-7/8	16-3/8	29-5/8	15-3/4	15-3/8
S08	24	16-1/2	16	13-3/8	18-3/8	29-5/8	15-3/4	15-3/8
S12	31	16-1/2	23	13-3/8	25-3/8	29-5/8	15-3/4	15-3/8
S16	39	16-1/2	31	13-3/8	33-3/8	29-5/8	15-3/4	15-3/8
S20	41	19	33	15-5/8	35-3/8	32-1/8	18-1/4	17-3/8

1. All dimensions approximate. Certified drawings available upon request.

Fan Coils

Dimensional Data—Large Capacity Fan Coils, Hideaway, Belt-Drive

Right-hand unit shown. (Hand of unit determined by cooling unit connection *when facing discharge*.)

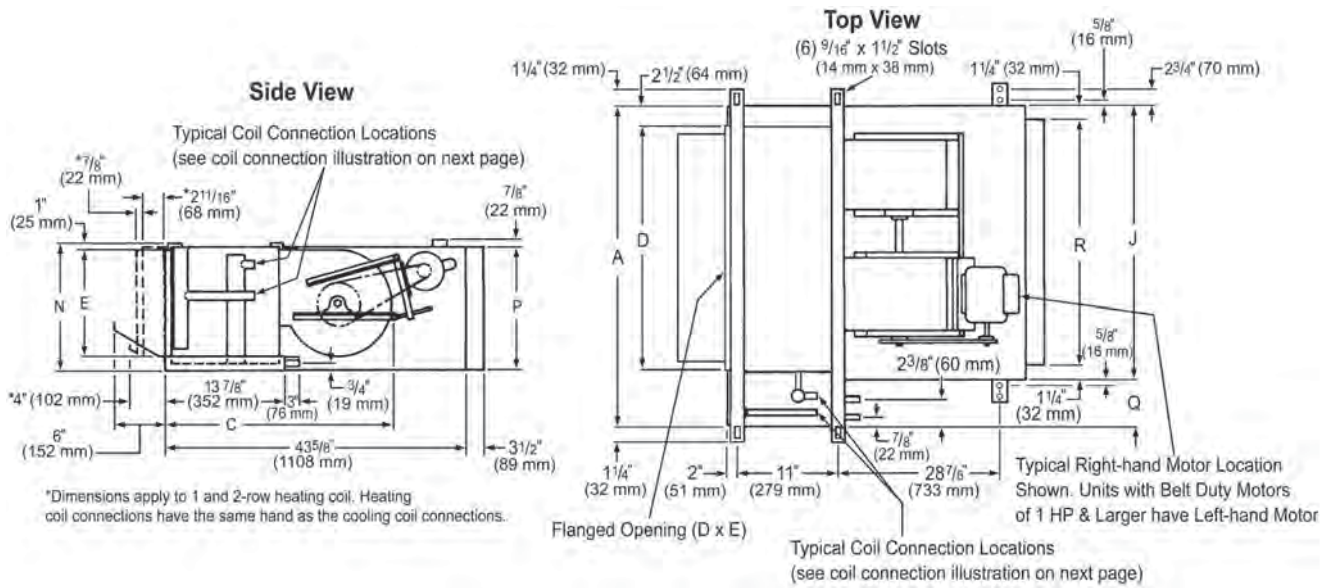

Rear View S06 & S08

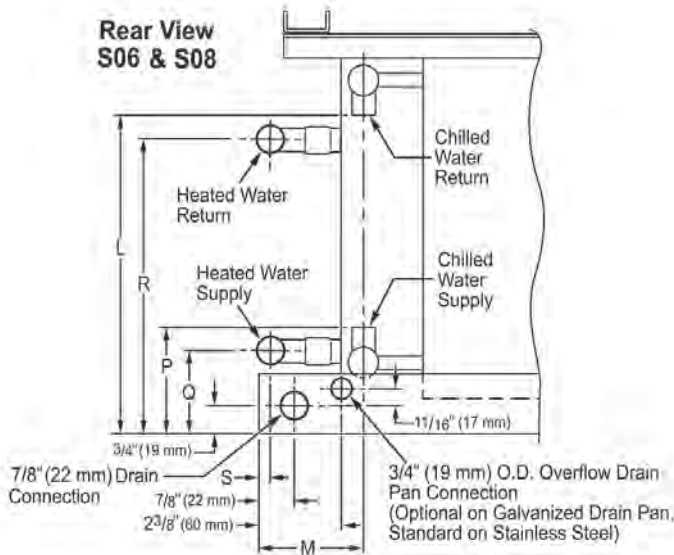

Rear View S16, S20, S30

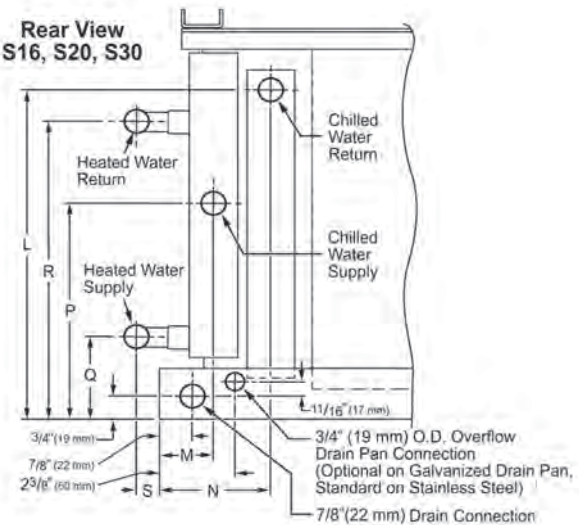

HHBB model	No. of fans	Unit dimensions (in) ¹									
		A	C	D	E	F	J	N	P	Q	R
S08	1	24	28-1/2	16-1/4	13-3/8	24	21	16-1/2	15-3/4	3	18-1/2
S12	1	31	28-1/2	23	13-3/8	31	28	16-1/2	15-3/4	3	25-1/2
S16	2	39	28-1/2	31	13-3/8	39	36	16-1/2	15-3/4	3	33-1/2
S20	2	41	28-1/2	33-1/4	15-3/8	41	38	18-3/4	18-1/4	3	35-1/2
S30	2	60	30	49	15-3/8	57	54	18-3/4	18-1/4	6	51-1/2

1. All dimensions approximate. Certified drawings available upon request.

Fan Coils

Dimensional Data—Large Capacity Fan Coils, Cabinet, Belt-Drive

Right-hand unit shown. (Hand of unit determined by cooling unit connection *when facing discharge*.)

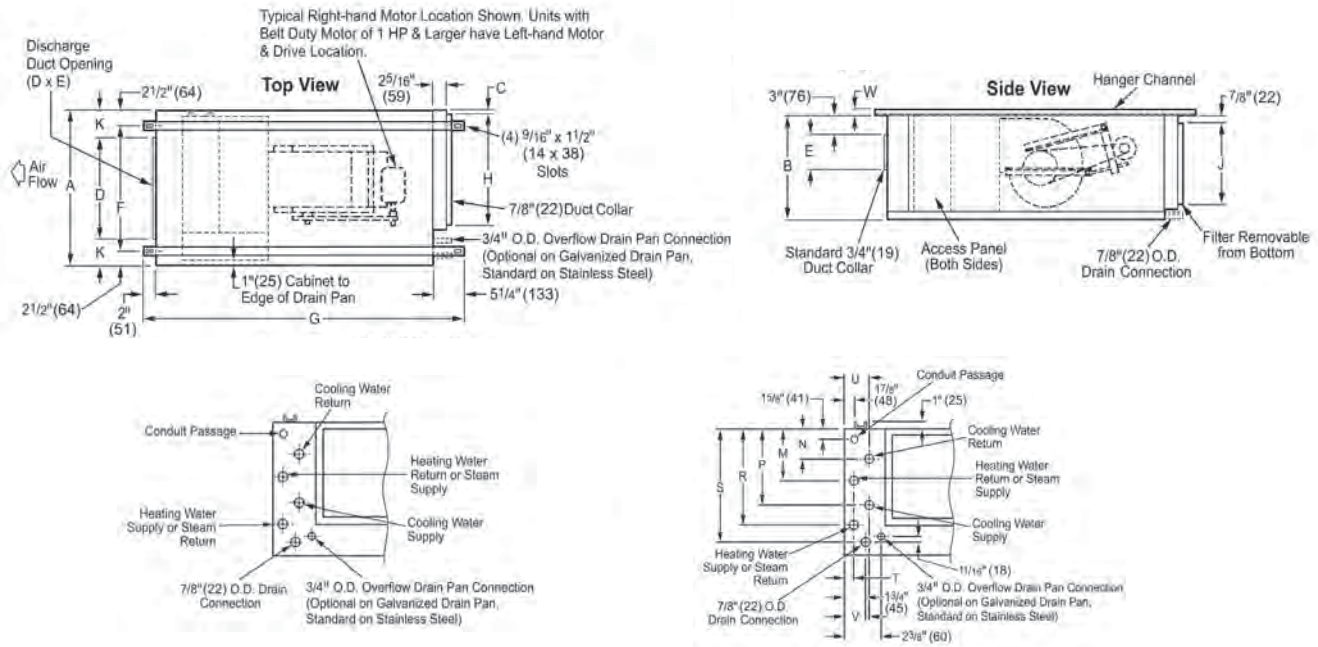

HCBB model	No. of fans	Unit dimensions (in) ¹									
		A	C	D	E	F	J	N	P	Q	R
S08	1	24	28-1/2	16-1/4	13-3/8	24	21	16-1/2	15-3/4	3	18-1/2
S12	1	31	28-1/2	23	13-3/8	31	28	16-1/2	15-3/4	3	25-1/2
S16	2	39	28-1/2	31	13-3/8	39	36	16-1/2	15-3/4	3	33-1/2
S20	2	41	28-1/2	33-1/4	15-3/8	41	38	18-3/4	18-1/4	3	35-1/2
S30	2	60	30	49	15-3/8	57	54	18-3/4	18-1/4	6	51-1/2

1. All dimensions approximate. Certified drawings available upon request.

ThinLine™ Vertical Cabinet Unit Heaters

- Seven unit sizes from 200 to 1,200 cfm
- Heavy-gauge galvanized steel construction for longer life
- Closed-cell insulation standard
- Auxiliary electric heat
- Fully concealed, exposed or recessed applications
- AHRI certified performance
- ETL and CETL safety agency approval listing

For more detail, refer to Catalog 722.

For the most current information, refer to DaikinApplied.com.

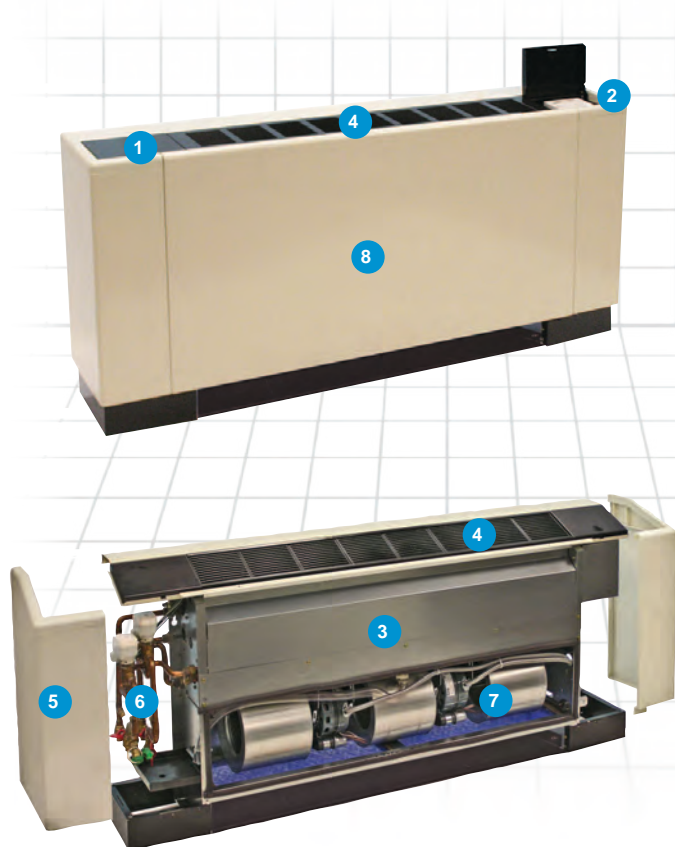

- Options**
 - Flat Top
 - Sloped Top
 - Hideaway
 - Control options**
 - 3-speed switch or low voltage interface board
 - Analog or digital thermostat
 - Remote or unit mounted
 - 3-speed or staged fan control
 - Hot water coil options**
 - 2, 3, or 4-row
 - Grille options**
 - Stamped or multi-directional outlet grilles
 - Return grille option
 - Extended end pockets**
 - 4" each side
 - 8" one side
 - Diverse, flexible valve and piping packages**
 - Software selectable factory-mounted, wired, and tested, or
 - Factory-assembled and shipped loose for field-mounting
 - Normally closed or open, on/off or modulating valves
 - Easily removed motor assembly**
 - For easy maintenance and service
 - Cabinet color options**
 - Antique Ivory
 - Cupola White
 - Soft Gray
 - Off-White
 - Putty Beige
- Electric heat options:**
- Auxiliary heat
 - Singlepoint power connections

Heating Performance—Hot Water Coil

Unit Size	Main Coil Rows	SCFM	Heating Performance			
			MBh (kW)	Q/ITD	Gpm (L/s)	WPD ft of H ₂ O (kPa)
02	4 Row	200	19.2 (5.6)	0.175 (0.092)	1.2 (0.08)	0.6 (1.8)
03	4 Row	265	27.2 (8.0)	0.247 (0.131)	1.9 (0.12)	1.5 (4.5)
04	4 Row	374	38.9 (11.4)	0.354 (0.187)	2.9 (0.18)	3.4 (10.2)
06	4 Row	554	52.6 (15.4)	0.478 (0.252)	4.6 (0.29)	9.0 (26.9)
08	4 Row	634	64.3 (18.8)	0.585 (0.308)	5.5 (0.35)	14.8 (44.2)
10	4 Row	795	80.8 (23.7)	0.735 (0.388)	6.7 (0.42)	11.1 (33.2)
12	4 Row	1022	103.8 (30.4)	0.944 (0.497)	8.3 (0.52)	18.3 (54.7)

* All performance measured on high speed tap, 115 V, zero ESP, with a throwaway filter. Heating performance is based on 70°F (21°C) entering air temperature, 180°F (82°C) entering hot water temperature with a 30°F (17°C) DT.

* Capacities shown are for 4-row coil configuration. For other configurations, consult catalog 723.

Fan Coils

Dimensional Data—Flat Top Unit Heaters

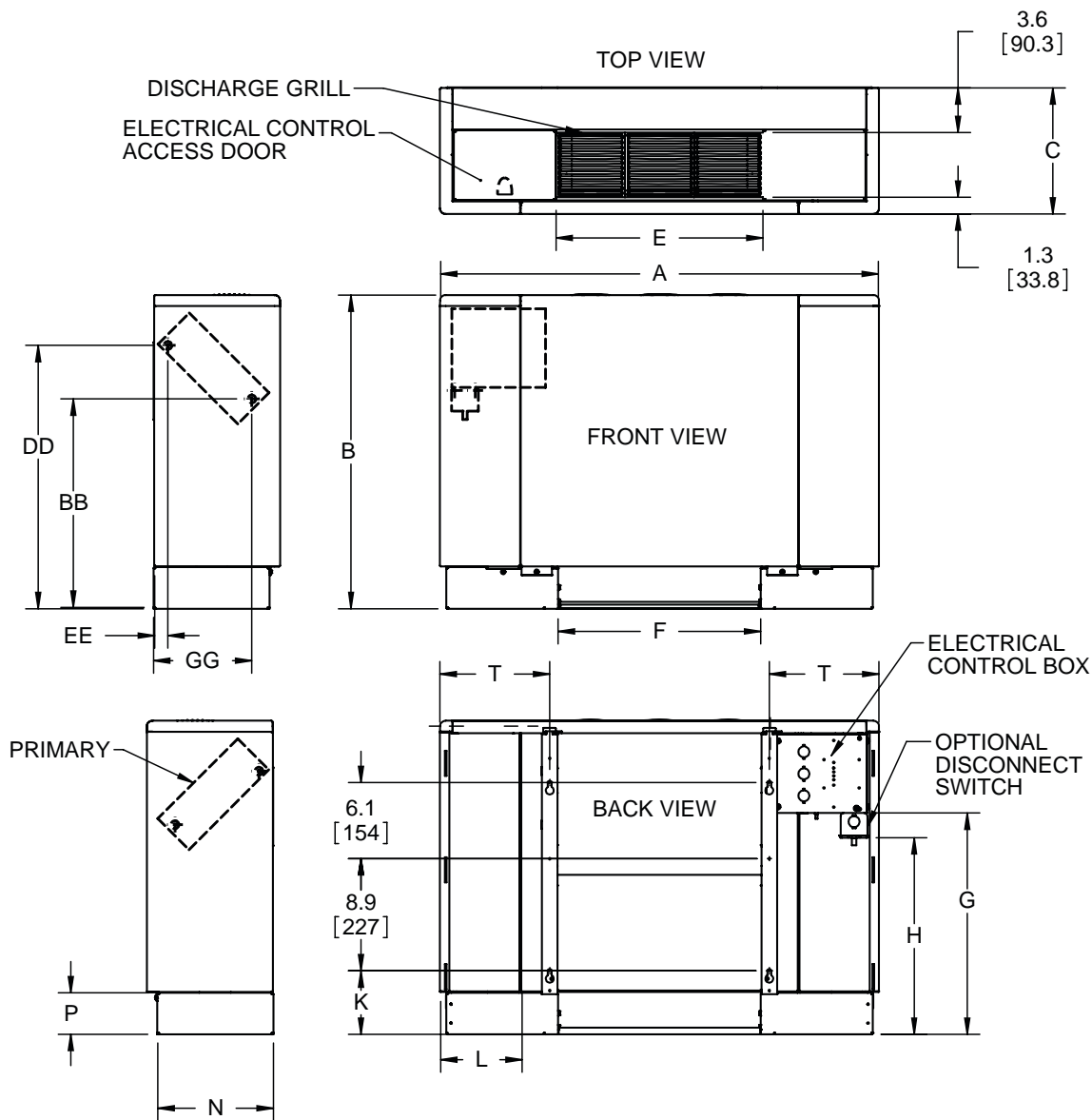

Dimension		S02		S03		S04		S06		S08		S10		S12	
		inch	mm	inch	mm	inch	mm	inch	mm	inch	mm	inch	mm	inch	mm
Unit Width	A	35.0	889	40.5	1029	46.0	1168	57.0	1448	62.5	1588	73.5	1867	84.5	2146
Unit Height	B	25.0	635	25.0	635	25.0	635	25.0	635	25.0	635	25.0	635	25.0	635
Unit Depth	C	10.0	254	10.0	254	10.0	254	10.0	254	10.0	254	10.0	254	10.0	254
Discharge Grille - Width	E	16.3	414	21.8	554	27.3	693	38.3	973	43.8	1113	54.8	1392	65.8	1671
Return Air Opening - Width	F	16.2	411	21.7	551	27.2	691	38.2	970	43.7	1110	54.7	1389	65.7	1669
Floor to Bottom Mtg Hole	K	5	127	5	127	5	127	5	127	5	127	5	127	5	127
Water Supply	BB	16.7	424	16.7	424	16.7	424	16.7	424	16.7	424	16.7	424	16.7	424
	GG	7.8	198	7.8	198	7.8	198	7.8	198	7.8	198	7.8	198	7.8	198
Water Return	DD	21	533	21	533	21	533	21	533	21	533	21	533	21	533
	EE	1.1	28	1.1	28	1.1	28	1.1	28	1.1	28	1.1	28	1.1	28

ThinLine™ Horizontal Cabinet Unit Heaters

- Seven unit sizes from 200 to 1,300 cfm
- Fully concealed, exposed or recessed applications
- 2-, 3- and 4-row main coil options
- Auxiliary electric heat
- Mixing box/economizer option
- AHRI-certified performance, ETL and CETL safety agency approval listing
- Factory-installed valve packages
- Multiple control options, including MicroTech controller
- Fiberglass or close-cell insulation options

For more detail, refer to Catalog 724.

For the most current information, refer to DaikinApplied.com.

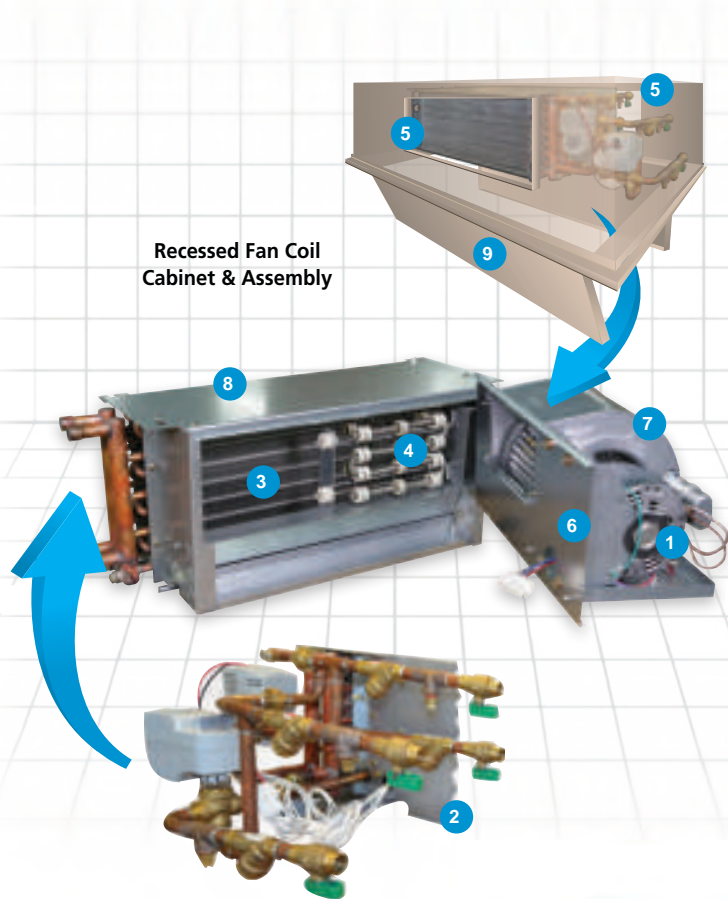

Recessed Fan Coil Cabinet & Assembly

- 1 3-Speed PSC or ECM motor(s)
- 2 Software selectable/factory-installed valve packages
- 3 Main hot water (2, 3, 4-row) coils
- 4 Auxiliary electric heat
- 5 Front/bottom discharge, bottom/rear return
- 6 Easily removable fan deck
- 7 Quiet forward curved blower(s)
- 8 Heavy-gauge galvanized steel construction
- 9 Large access doors (exposed/recessed units)

Available options:

- MicroTech controller
- Multiple filters including MERV13
- Low-voltage/line-voltage controls
- Choice of 5 cabinet colors



Exposed ceiling unit



Recessed ceiling unit



Hideaway unit

Fan Coils

Performance Data—ThinLine Horizontal Unit Heaters

Heating Performance: Standard Rating Coil

Unit Model	Unit Size	Nominal Air Flow SCFM	Number of Heating Rows	Heating Performance MBH	Hot Water Flow gpm	HW Pressure Drop ft
FHHH	02	200	3	29.9	2.0	0.9
	03	300	3	35.1	2.4	1.3
	04	400	3	42.3	2.9	2.0
	06	600	3	65.2	4.4	5.9
	08	800	3	73.6	5.0	8.2
	10	1000	3	104.8	7.1	8.3
	12	1200	3	133.6	9.1	15.0
FHHC	02	200	3	28.8	1.9	0.9
	03	300	3	34.6	2.3	1.2
	04	400	3	40.9	2.8	1.9
	06	600	3	62.9	4.3	5.5
	08	800	3	66.2	4.5	6.6
	10	1000	3	92.1	6.2	6.5
	12	1200	3	115.3	7.8	11.3

Hideaway unit without plenum at 0.05" ESP; Cabinet unit with 1" Throwaway filter, bottom return/front discharge configuration at 0" ESP
Heating: EAT=70; EWT/LWT=180°F/150°F

Units with ECM Heating Performance

Unit Model	Unit Size	Air Flow SCFM	Number of Primary Rows	Heating Performance		
				Heating Capacity, MBH	Hot Water Flow, gpm	Water Pressure Drop, ft
FHHH, FHHC, FHHR any configuration	02	329	3	30.4	2.0	1.0
	03	393	3	34.7	2.3	1.2
	04	459	3	42.8	2.9	2.1
	06	704	3	64.2	4.4	5.7
	08	755	3	74.5	5.1	8.4
	10	1124	3	105.4	7.1	8.4
	12	1464	3	135.9	9.2	15.5

ECM motor at High speed setting, any external static pressure up to 0.5"
Unit of any configuration with standard throwaway (MERV 4) filter
Heating: EAT=70; EWT/LWT=180°F/150°F

Dimensional Data

Hideaway Cabinet Unit Heater, front discharge – free return

Top View

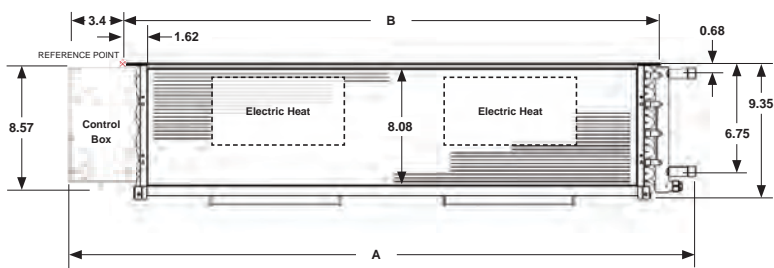
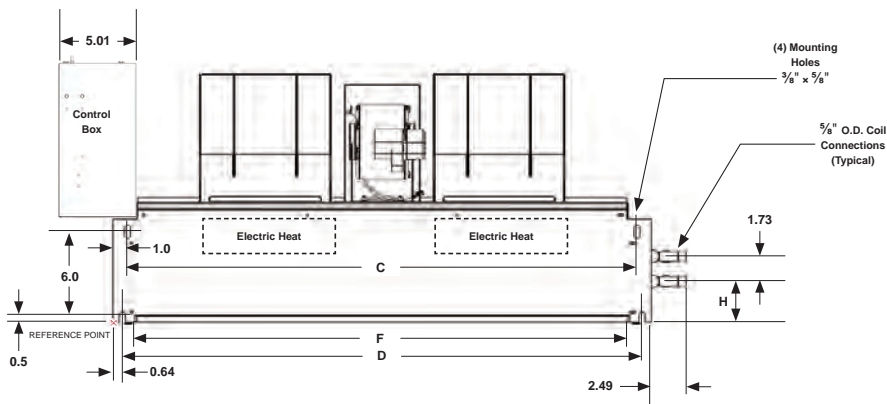

Front View

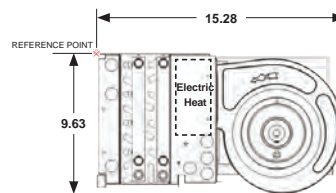

Side View

Dimension		S02	S03	S04	S06	S08	S10	S12
		inch (mm)	inch (mm)	inch (mm)	inch (mm)	inch (mm)	inch (mm)	inch (mm)
Overall Unit Width	A	28.48 (723)	28.48 (723)	33.98 (863)	44.98 (1142)	50.48 (1282)	61.48 (1562)	72.48 (1841)
Chassis Width	B	20.63 (524)	20.63 (524)	26.13 (664)	37.13 (943)	42.63 (1083)	53.63 (1362)	64.63 (1641)
Mounting Hole Distance (Rear)	C	18.64 (473)	18.64 (473)	24.14 (613)	35.14 (892)	40.64 (1032)	51.64 (1312)	62.44 (1702)
Mounting Slot Location (Front)	D	19.35 (491)	19.35 (491)	24.85 (631)	35.85 (911)	41.35 (1050)	52.35 (1330)	63.35 (1609)
Discharge Opening - Width	F	17.39 (442)	17.39 (442)	22.84 (581)	33.89 (867)	39.39 (1000)	50.39 (1280)	61.39 (1559)
Primary Coil Location	H	1.81 (46) for 2- or 3-row primary coil; 2.81 (71) for 4-row primary coil						
Secondary Coil - Standard Capacity	L	2.86 (73)						
Secondary Coil - High Capacity	L	0.86 (22)						
Secondary Coil - Standard Capacity	K	5.0 (127)						
Secondary Coil - High Capacity	K	7.0 (178)						

Fan Coils

Dimensional Data

Exposed Cabinet Unit Heater, front discharge – rear return

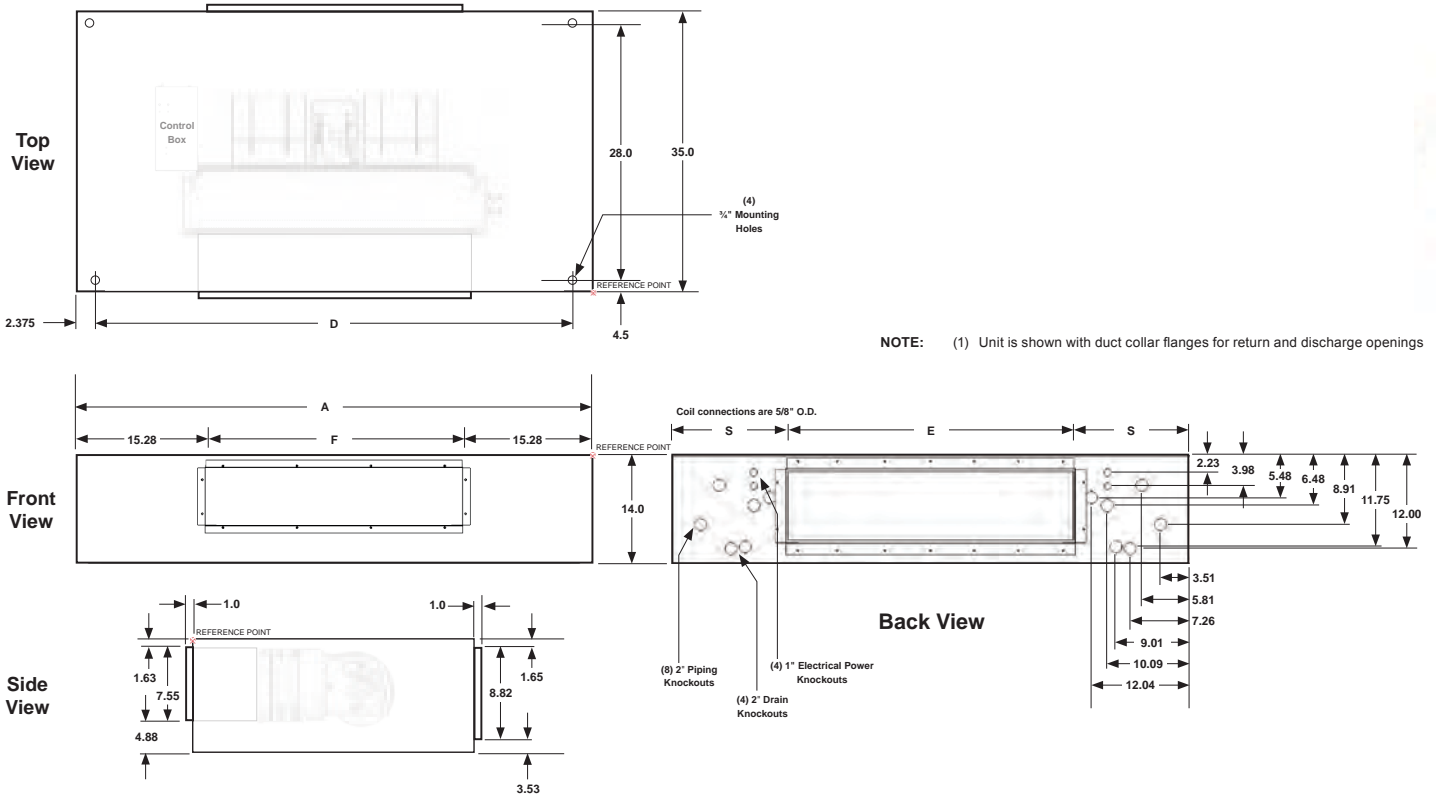

Dimension		S02	S03	S04	S06	S08	S10	S12
		inch (mm)	inch (mm)	inch (mm)	inch (mm)	inch (mm)	inch (mm)	inch (mm)
Overall Unit Width	A	47.64 (1210)	47.64 (1210)	53.14 (1350)	64.14 (1629)	69.64 (1769)	80.63 (2048)	91.64 (2328)
Mounting Hole Distance	D	40.64 (1032)	40.64 (1032)	46.14 (1172)	57.14 (1451)	62.64 (1591)	73.64 (1870)	84.64 (2150)
Return Air Opening - Width	E	19.0 (483)	19.0 (483)	22.9 (581)	34.5 (876)	38.4 (975)	50.0 (1270)	61.6 (1565)
Discharge Opening - Width	F	17.09 (434)	17.09 (434)	22.59 (574)	33.59 (853)	39.09 (993)	50.09 (1272)	61.09 (1552)
Return Air Opening Location	S	14.32 (364)	14.32 (364)	15.13 (384)	14.82 (376)	15.63 (397)	15.32 (389)	15.01 (381)

Steam/Hot Water Unit Heaters, Vertical and Horizontal

- 2-pipe applications, up to 150 psig steam or 220 psig, 375°F water
- Copper coils, 1/2" diameter, with aluminum fins (12 per inch)
- Horizontal louvers standard, vertical louvers an option on all models
- Intermittent or continuous fan operation controls (optional)
- Standard 115/60/1 PSC motors, enclosed with thermal overload protection
- 230/60/1; 200/60/3; 230/460/60/3 motors available
- Explosion proof motors available (FUDX and FUHX models)
- Finger-proof fan guards standard
- CSA Listed
- Baked-on, textured paint
- Optional air deflectors: cone jet, truncone, louvers and 3 or 4 cone anemostat

For more detail, refer to Catalog 702.

For the most current information, refer to DaikinApplied.com.

Model FUDH



Model FUHH



Performance Data—Model FUHH and Model FUDH; 2 lbs Steam¹, 60°F Entering Air, High Motor Speed

Model	Btu/hr	Condensate lb/hr	Sq ft EDR	Cfm	Outlet velocity (fpm)	Final air temp (°F)	Air Data				Heat spread @ max height	Sound class	
							Max. mounting height (ft) ²	Heat spread @ max height	Sound class	Sound class			
Vertical Units													
FUDH-42	42,000	43	175	950	779	103	11	15	17	11	II	1/20	1550
FUDH-59	59,000	61	246	1150	943	111	13	18	20	13	II	1/20	1550
FUDH-78	78,000	81	325	1550	992	110	14	19	22	14	II	1/8	1550
FUDH-95	95,000	99	396	1775	1136	113	16	21	24	16	II	1/8	1550
FUDH-139	139,000	144	579	2500	1284	116	18	24	27	18	III	1/4	1075
FUDH-161	161,000	167	671	2900	1490	115	21	28	31	21	III	1/4	1075
FUDH-193	193,000	200	804	3900	1643	109	23	31	34	23	IV	1/2	900
FUDH-212	212,000	219	883	4300	1812	109	25	33	37	25	IV	1/2	1075
FUDH-247	247,000	256	1029	5130	1805	107	26	34	39	26	IV	5/8	900
FUDH-279	279,000	288	1163	5800	2040	107	30	37	45	30	V	5/8	1075
FUDH-333	333,000	345	1388	6600	1968	110	30	37	45	30	V	1	1075
FUDH-385	385,000	398	1604	7860	1930	106	30	36	45	30	VI	1	1140
FUDH-500	500,000	518	2083	10,790	2490	103	37	44	56	37	VI	1-1/2	1140
FUDH-610	610,000	631	2542	12,350	2345	106	36	43	54	36	VI	1-1/2	1140
Horizontal Units													
FUHH-18	18,000	18	75	400	510	102	9	15	17	11	II	1/30	1550
FUHH-24	24,000	25	100	450	580	109	9	18	18	13	II	1/30	1550
FUHH-33	33,000	35	138	630	510	109	10	19	20	14	II	1/15	1550
FUHH-47	47,000	49	196	730	600	120	12	21	25	16	III	1/15	1550
FUHH-63	63,000	66	263	1120	605	112	14	24	29	18	III	1/10	1550
FUHH-86	86,000	89	358	1340	730	119	15	28	31	21	III	1/10	1550
FUHH-108	108,000	111	450	1550	625	125	15	31	32	23	III	1/8	1075
FUHH-121	121,000	126	504	1775	715	123	16	34	33	25	III	1/8	1075
FUHH-165	165,000	170	688	2500	750	121	17	37	34	26	IV	1/4	1075
FUHH-193	193,000	200	804	2900	870	122	18	37	37	30	IV	1/4	1075
FUHH-258	258,000	267	1075	3900	920	121	19	36	40	30	V	1/3	1075
FUHH-290	290,000	300	1208	4300	1010	122	20	44	44	37	V	1/2	1100
FUHH-340	340,000	352	1417	5130	965	121	20	43	46	36	V	1/2	1100

1. For hot water performance data, see Catalog FC-FUHH00.
2. Applies to most popular motor.

Fan Coils

Dimensional Data—Steam/Hot Water Unit Heaters

Model FUDH

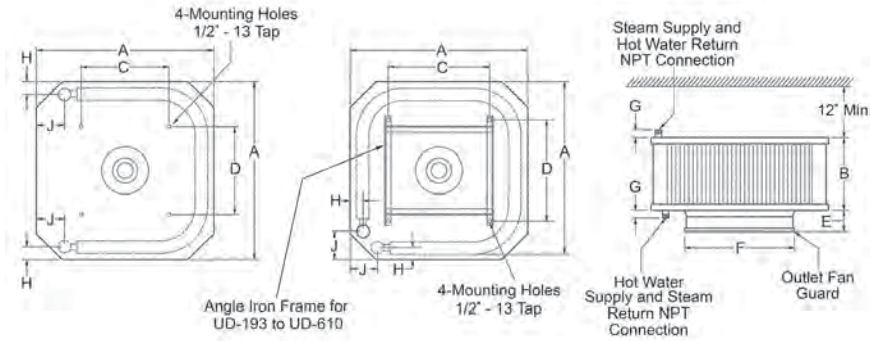

Model FUHH

Sizes 18—86

Sizes 108—340

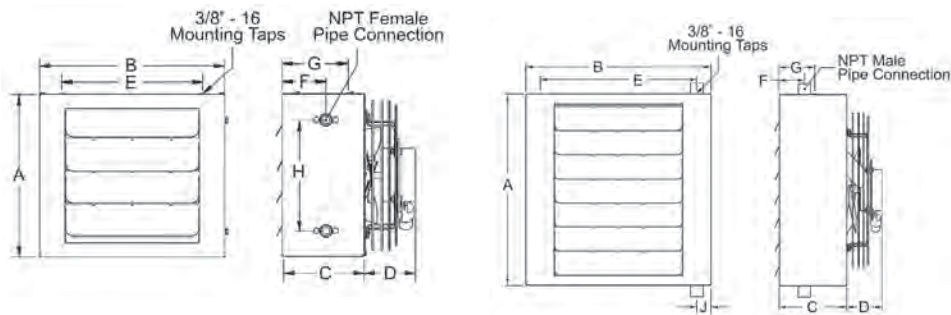

Model FUHH and Model FUDH Dimensions (inches)

Model	A	B	C	D	E	F	G	H	J	NPT connections	Fan dia.	Approx. shipping weight (lbs)
Vertical Units												
FUDH-42, FUDH-59	23	6-3/8	12	12	3-1/8	15	2-3/4	1-7/8	3-1/4	1-1/2	13-3/4	52
FUDH-78, FUDH-95	25	6-3/8	13	13	3-1/8	17	2-3/4	1-7/8	3-1/4	1-1/2	15-3/4	64
FUDH-139, FUDH-161	35	10-3/8	14-7/16	14-7/16	3-1/8	18-7/8	2-3/4	2	3-1/4	1-1/2	17-3/4	99
FUDH-193, FUDH-212	30	12-3/8	19	17	4	20-7/8	2-3/4	2	3-5/8	2	19-3/4	126
FUDH-247, FUDH-279	35	12-3/8	20	18	4	22-7/8	2-3/4	2	3-5/8	2	21-3/4	154
FUDH-333, FUDH-385	35	18-3/8	21	21	4	24-3/4	2-3/4	2-1/2	4-1/2	2-1/2	23-3/4	189
FUDH-510	43	18-3/8	25	25	4	28-3/4	2-3/4	2-1/2	4-1/2	2-1/2	27-3/4	270
FUDH-610	43	18-3/8	27	27	4	30-3/4	2-3/4	2-1/2	4-1/2	2-1/2	29-3/4	290
Horizontal Units												
FUHH-18	15	16-7/8	7-1/2	4-1/2	12	3-1/2	5	10	—	3/4	9	18
FUHH-24	15	16-7/8	7-1/2	4-1/2	12	3-1/2	5	10	—	3/4	9	19
FUHH-33	19	19-3/4	7-1/2	4-3/4	12	3-1/2	5	14	—	3/4	12	35
FUHH-47	19	19-3/4	7-1/2	4-3/4	12	3-1/2	5	14	—	3/4	12	36
FUHH-63	19	25-3/4	8-1/2	4-3/4	18	3-1/2	5	14	—	3/4	14	51
FUHH-86	19	25-3/4	8-1/2	4-3/4	18	3-1/2	5	14	—	3/4	14	52
FUHH-108	27	25-7/8	9-1/2	6-1/4	18	3-1/2	5-1/4	—	2	1-1/2	18	76
FUHH-121	27	25-7/8	9-1/2	6-1/4	18	3-1/2	5-1/4	—	2	1-1/2	18	77
FUHH-165	27	31-7/8	10	6-1/4	24-7/8	3-1/2	6-1/4	—	2	1-1/2	20	95
FUHH-193	27	31-7/8	10	8-3/8	24-7/8	3-1/2	6-1/4	—	2	1-1/2	20	96
FUHH-258	33	40-13/16	11	8-3/8	32-7/8	3-1/2	6-1/4	—	2-1/4	2	22	165
FUHH-290	33	40-13/16	11	8-3/8	32-7/8	3-1/2	6-1/4	—	2-1/4	2	22	167
FUHH-340	39	40-13/16	12	8-3/8	32-7/8	3-1/2	7-1/4	—	2-1/4	2	24	182

Unit Ventilators

AAF®-HermanNelson® Unit Ventilator Product Summary Chart

Model:

**Ceiling-Mounted
Fan Coil
Unit Ventilators**

**Floor-Mounted
Fan Coil
Unit Ventilators**

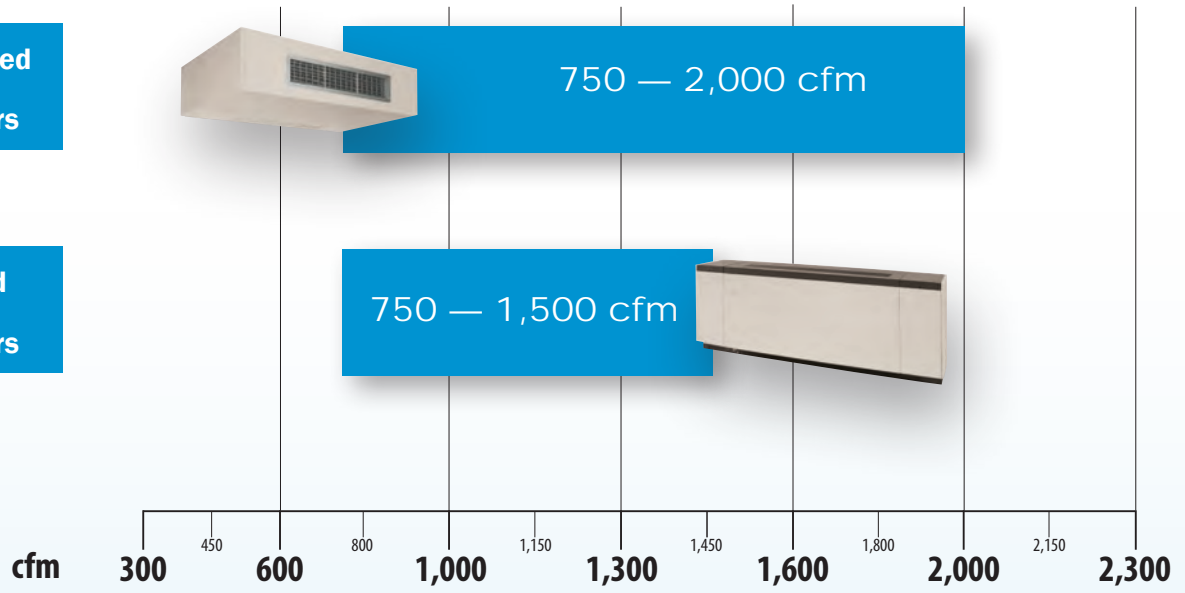

Model:

**Floor-Mounted
Self-Contained
Air Conditioner
and Air to Air
Heat Pump
Unit Ventilators**

**Water Source
Heat Pump
Unit Ventilators**

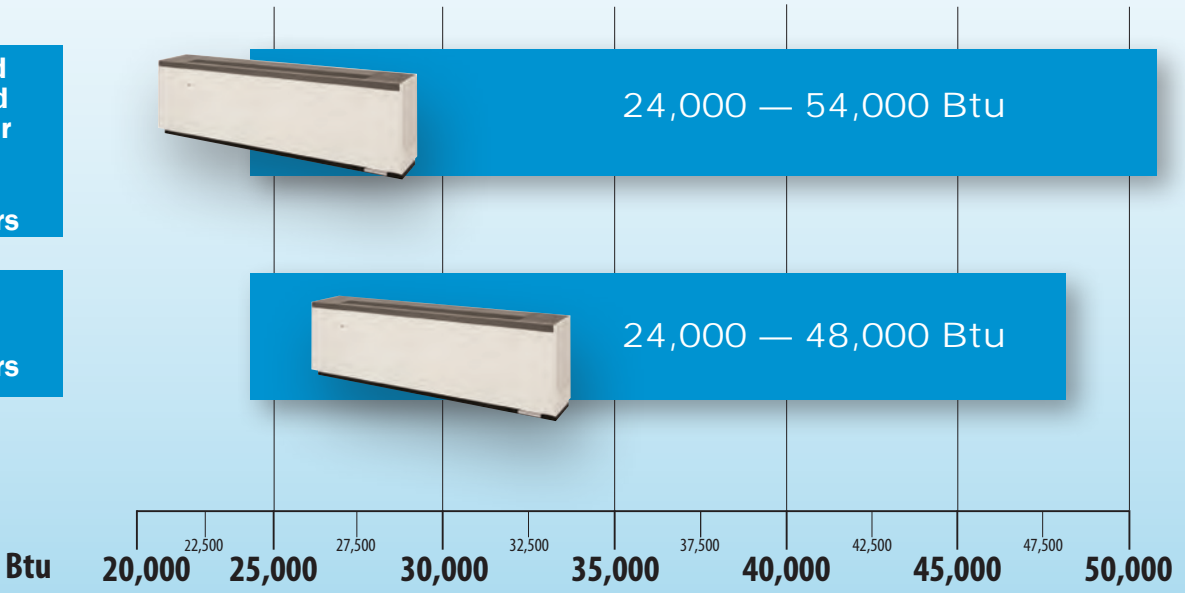

Unit Ventilators

AAF[®]-HermanNelson[®] Unit Ventilators

- Built-up floor and ceiling units, plus air source air conditioner, air-to-air heat pump or water source heat pump (boiler/tower and geothermal)
- Draw-through design with face and bypass damper control for superior temperature and dehumidification control
- GentleFlo™ air moving system for very quiet operation
- Welded frame construction and industrial strength cabinet and finish for long life
- Unique draw-thru design provides uniform air distribution across the coil for even discharge air temperatures
- Controls flexibility—MicroTech[®] II controls with our Open Choices™ feature for easy integration with the BAS of your choice
- Digital Ready™ feature provides industry standard Direct Digital Control (DDC) components for easy integration of unit controllers by others
- Economizer, Demand Control Ventilation (DCV) and Part Load, Variable Air options allow you to reduce operating costs while closely matching classroom comfort requirements

For more detail, refer to Catalogs UV1600 (AV), UV1610 (AH), UV1620 (AZ), UV1640 (AR, ER, & GR) and UV1650 (AE).

For the most current information, refer to DaikinApplied.com.



Models AHF, AHB, AHV, and AHR ceiling units
ECM motor standard



Models AVS, AVB, AVV, and AVR floor units



Models AZQ, AZR, AZU, AEQ, ARQ, ERQ and GRQ self-contained floor units



AAF®-HermanNelson® Fan Coil Unit Ventilators

Model AV-Vertical Fan Coil UV with Hot Water, Steam, Electric Heat or DX Cooling

AV/AH horizontal and vertical blade louvers

Models AV, AH

Model AH - Horizontal Fan Coil UV with Hot Water, Chilled Water, Steam, Electric Heat or DX Cooling



Outside

Inside

Louvers

- Constructed of heavy gauge aluminum (painted or unpainted) for maximum durability
- Designed to maximize outdoor air intake and keep rain and moisture out

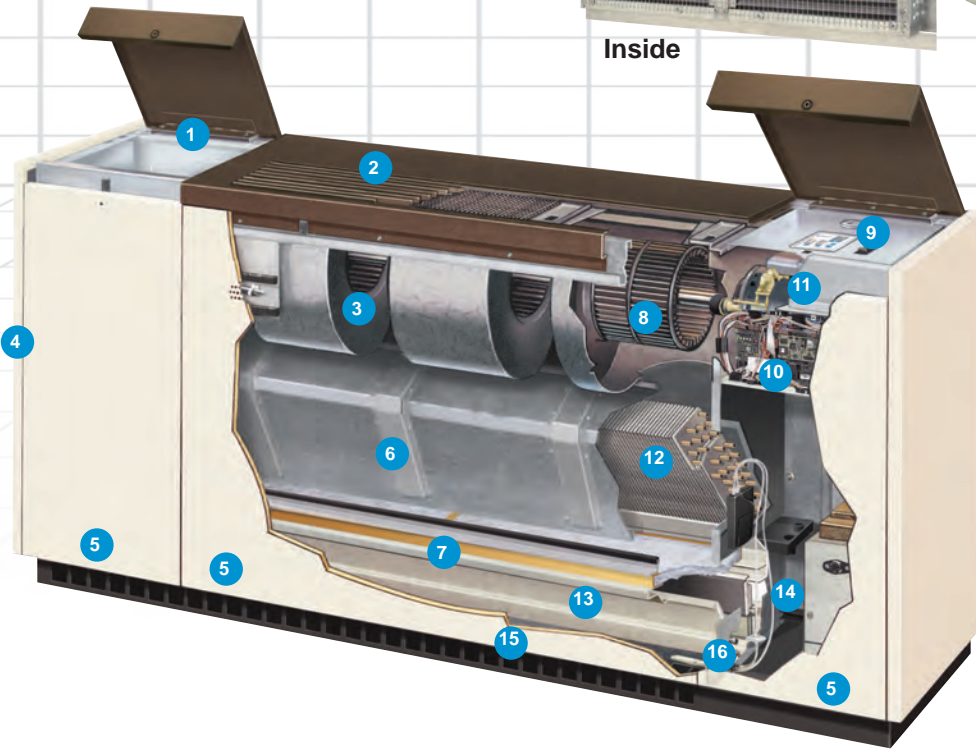

- 1 Dual top hinged access doors**
 - Provides easy access to motor and end bearing
- 2 Non-glare top**
 - Scuff resistant
- 3 Fan housing**
 - Logarithmic expansion for quieter operation
- 4 Welded frame construction**
 - Promotes long life
- 5 Three sectionalized front access panels**
 - Easy access to unit interior
- 6 Face and bypass damper**
 - Superior dehumidification control

- 7 Full length filter**
 - All air delivered into the classroom is filtered
 - One piece design makes filter changes quick and easy
- 8 Fan wheel design**
 - Larger and fewer blades move air quietly
- 9 MicroTech® II local user interface**
 - Displays unit condition
 - Diagnostics capability
 - Settable unit functions
- 10 MicroTech II controls**
 - LonWORKS®, BACnet®, Metasys® N2 Open communication capability

- 11 Maintainable motor location**
 - Motor location out of airstream for easy access
- 12 High heat transfer coil design**
 - Provides more cooling capacity
- 13 Integral drain pan**
 - Standard in all units to permit future cooling
- 14 Insulated, double-wall outdoor air damper**
 - Seals without twisting
- 15 Indoor return air damper**
 - Unique, free floating design to prevent cold air gusts from directly entering the classroom
- 16 Optional factory-mounted CO₂ sensor**

Two-Stage Self-Contained Unit Ventilators—Models AZ and AE

Model AZ – Air-Source Air Conditioner with Hot Water, Steam or Electric Heating
Unit sizes 024, 036, 044 & 054

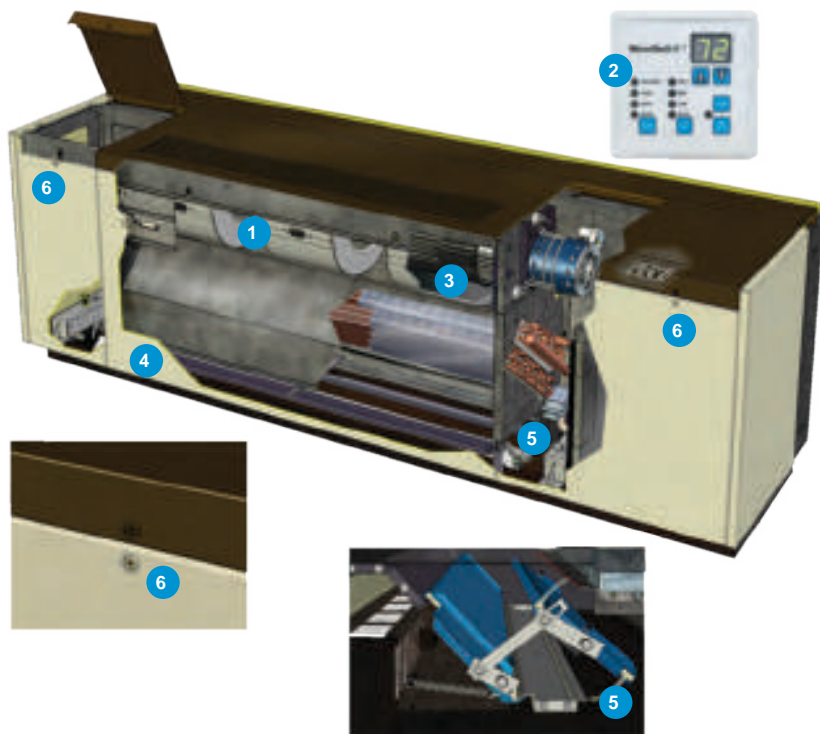

- 1 Modular fan section**
 - Improved balance and alignment
 - Easy accessibility
 - Removable
- 2 MicroTech® II factory-integrated controls**
 - Provide superior comfort control
 - Easily integrate into the building automation system of your choice
- 3 Superior airflow**
 - Quiet, aerodynamic fans utilizing GentleFlo technology
 - Unique Draw-Thru Design provides uniform air distribution across the coil for even discharge air temperatures
- 4 Easy installation and maintenance**
 - Center front panel provides easy access to full-length air filter
 - Side and end panels provide easy access to piping and drain pan
 - Hinged doors on top provide easy access to motor, electrical and control components
- 5 Insulated, double-wall outdoor air damper**
 - Provides superior mixture of outdoor air and room air for precise temperature control
 - Seals tightly without twisting
- 6 Tamper-resistant fasteners**

Model AE – Air-Source Heat Pump

Model AE utilizes refrigerant for cooling and heating. Size 024 is just right for new construction and for retrofit applications. Unit sizes 036, 044 and 054 are for replacement applications only.

Models AZ and AE wall sleeve

- Heavy duty construction
- Simplifies insulation and service



Inside

Models AZ and AE louvers

- Constructed of heavy gauge aluminum (painted or unpainted) for maximum durability
- Designed to maximize outdoor air intake and keep rain and moisture out

Water Source Heat Pump Self-Contained Unit Ventilators

Model AR – Standard Range
Model ER – Extended Range
Model GR – Geothermal Range
Unit sizes 024, 040 & 048

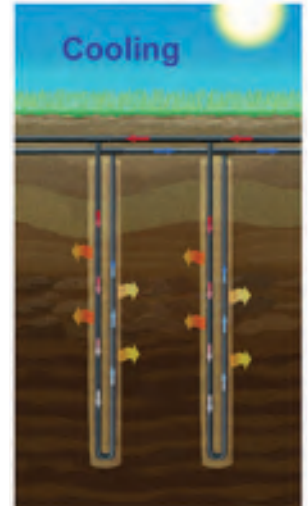
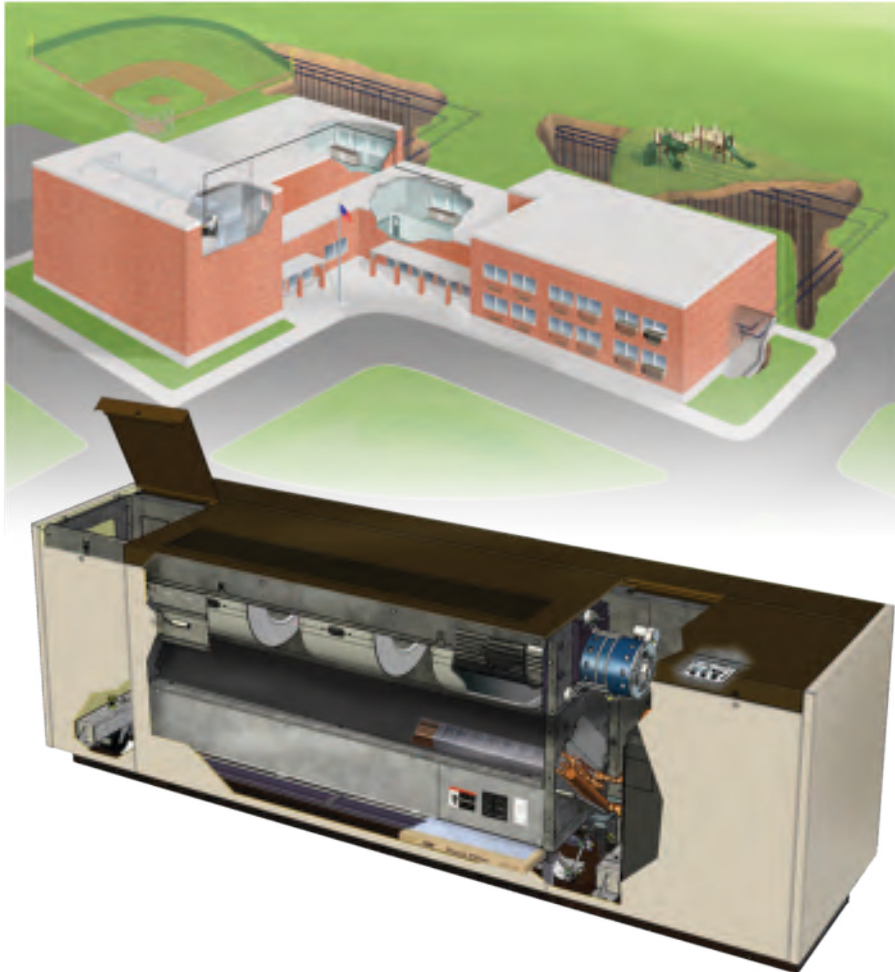

Rejection of heat into the ground



Addition of warmth from the ground

The Geothermal System (Model GRQ)

Model GRQ Ground Source heat pumps utilize the natural properties of the earth to provide heating and cooling to a building. Heat addition and rejection take place below the ground, inside hundreds of feet of high density polyethylene pipe, known as a ground loop. Fluid is circulated through the ground loop and into the geothermal units. The Geothermal heat pump unit simply amplifies and directs conditioned air to the desired location.

In the Heating Mode, the earth acts as a heat source, allowing the circulating fluid to extract natural heat from the earth and transfer it to the space where it can be used for heating.

In the Cooling Mode, the earth acts as a heat sink enabling the circulating fluid to transfer the excess heat, absorbed by the unit, from the building zones to earth where it is absorbed and stored for future heating requirements.

Features and Options

Three different economizer types for “free” cooling

- Basic—compares inside and outside temperature
- Expanded—compares inside and outside temperature, and outside air relative humidity to help prevent the entrance of humid outside air
- Leading Edge—compares temperature and relative humidity of inside and outside air (a true enthalpy economizer) to help prevent the entrance of humid outside air

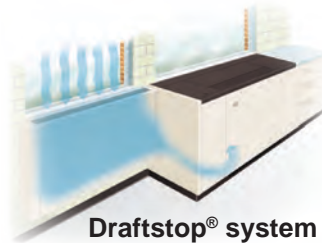

Draftstop® system (AV model only)

- Intercepts cold drafts from windows
- Not available with Self-contained unit models



Optional Time Clock

- As an option, stand-alone, non-servant unit ventilators can be equipped with a unit-mounted, digital, 24-hour/7-day time clock with 20 programs.
- Factory-wired to automatically place the unit into occupied or unoccupied mode based upon its schedule.
- Large keys with circular programming for easy schedule setup
- LCD display
- Manual 3-way override (On/Auto/Off)
- Capacitor backup to retain program memory during power outages.



MicroTech II DDC controls

- Precise, efficient operation
- User-friendly keypad with visual display
- Plug-in interface to BAS of your choice (LONWORKS® SCC, BACnet® MS/TP, Metasys® N2 Open)
- Part-load, variable air option varies fan speed automatically to meet room load, helping to provide comfort and reduce operating costs

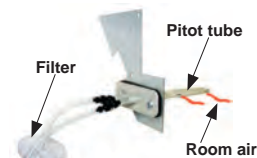

CO₂ sensor and unit-mounted sensing device

- Modulates amount of outside air to meet ASHRAE Standard 62.1-2004 requirements and lower operating costs



Optional remote room air sensor

- With tenant override



Optional expanded room air sensor

- With variable temperature adjustment (+/- 3 degrees)
- With tenant override



Optional deluxe room air sensor

- Individual room temperature control with variable temperature adjustment (54 to 82 degrees)
- Not available with self-contained unit models
- Not recommended for any DX system
- With tenant override

Unit Ventilators

Physical Data—Unit Ventilators

Built Up Floor Units—Models AV

Unit series			S07	S10	S13	S15
Nominal airflow, cfm (L/s)			750 (354)	1000 (472)	1250 (590)	1500 (708)
Filter data	Nominal size	inches	10 × 36-1/2 × 1	10 × 48-1/2 × 1	10 × 60-1/2 × 1	10 × 36-1/2 × 1
		mm	254 × 927 × 25	254 × 1232 × 25	254 × 1537 × 25	254 × 927 × 25
	Area	ft ² (m ²)	2.54 (0.24)	3.37 (0.31)	4.2 (0.39)	5.08 (0.47)
Quantity			1	1	1	2
Shipping weight, lb (kg) ¹	16 5/8" deep units		350 (158)	425 (193)	495 (225)	570 (259)
	21 7/8" deep units		370 (168)	445 (202)	525 (238)	600 (272)
Height, inches (mm)			30 1/8 (765)			
Depth, inches (mm)			16-5/8 (422)	16-5/8 (422)	16-5/8 (422)	16-5/8 (422)
			21-7/8 (556)	21-7/8 (556)	21-7/8 (556)	21-7/8 (556)
Width, inches (mm) ²			62 (1575)	74 (1880)	86 (2184)	98 (2489)

1. Approximate weights based on face and bypass damper controlled unit with 4-row cooling coil, high capacity hot water coil and MicroTech II controls.

2. Measurement is without end panels.

Built Up Ceiling Units—Models AH

Unit series			H07	H10	H13	H15	H20
Nominal airflow, cfm (L/s)			750 (354)	1000 (472)	1250 (590)	1500 (708)	2000 (994)
Filter data	Nominal size	inches	10 × 36-1/2 × 1	10 × 48-1/2 × 1	10 × 60-1/2 × 1	10 × 36-1/2 × 1	10 × 36-1/2 × 1
		mm	254 × 927 × 25	254 × 1232 × 25	254 × 1537 × 25	254 × 927 × 25	254 × 914 × 25
	Area	ft ² (m ²)	2.54 (0.24)	3.37 (0.31)	4.2 (0.39)	5.08 (0.47)	5.08 (0.47)
Quantity			1	1	1	2	2
Shipping weight, lb (kg) ¹	Discharge air arrangement	AH, AT, BD, FD, FG ²	385 (179)	465 (211)	540 (245)	600 (272)	680 (309)2
Height, inches (mm)			16-5/8 (422)	16-5/8 (422)	16-5/8 (422)	16-5/8 (422)	16-5/8 (422)
Depth, inches (mm)	AH, AT		36 (914)	36 (914)	36 (914)	36 (914)	—
	BD, FD, FG ²		40 (1016)	40 (1016)	40 (1016)	40 (1016)	40 (1016)
Width, inches (mm) ³			62 (1575)	74 (1880)	86 (2184) 98	98 (2489)	98 (2489)

1. Approximate weights based on face and bypass damper controlled unit with 4-row cooling coil, high capacity hot water coil and MicroTech II controls.

2. FD and FG are for 2000 cfm only.

3. Measurement is without end panels.

Self-Contained Floor Units—Models AZ & AE

Unit series			024	036	044	054
Nominal airflow, cfm (L/S)			1000 (472)	1250 (590)	1500 (708)	1500 (708)
Filter data	Nominal size	inches	10 × 48-1/2 × 1	10 × 60-1/2 × 1	10 × 36-1/2 × 1	10 × 36-1/2 × 1
		mm	254 × 1232 × 25	254 × 1537 × 25	254 × 927 × 25	254 × 927 × 25
	Area	ft ² (m ²)	3.37 (0.31)	4.2 (0.39)	5.08 (0.47)	5.08 (0.47)
Quantity			1	1	2	2
Shipping weight, lb (kg)			885 (402)	975 (442)	1075 (448)	1075 (448)
Height, inches (mm)			30 (762)	30 (762)	30 (762)	30 (762)
Room depth, inches (mm)			16-5/8 (422)	16-5/8 (422)	16-5/8 (422)	16-5/8 (422)
			21-7/8 (556)	21-7/8 (556)	21-7/8 (556)	21-7/8 (556)
			28 (711)	28 (711)	28 (711)	28 (711)
Width inches, (mm)			86 (2184)	98 (2489)	110 (2794)	110 (2794)

Measurement is without end panels.

Water Source Heat Pump Floor Units—Models AR, ER & GR

Unit series			024	040	048
Nominal airflow, cfm (L/S)			1000 (472)	1250 (590)	1500 (708)
Filter data	Nominal size	inches	10 × 48-1/2 × 1	10 × 60-1/2 × 1	10 × 36-1/2 × 1
		mm	254 × 1232 × 25	254 × 1537 × 25	254 × 927 × 25
	Area	ft ² (m ²)	3.37 (0.31)	4.2 (0.39)	5.08 (0.47)
Quantity			1	1	2
Shipping weight, lb (kg)			690 (310)	720 (325)	760 (340)
Height, inches (mm)			30 (762)	30 (762)	30 (762)
Room depth, inches (mm)			16-5/8 (422)	16-5/8 (422)	16-5/8 (422)
			21-7/8 (556)	21-7/8 (556)	21-7/8 (556)
			28 (711)	28 (711)	28 (711)
Width inches, (mm)			86 (2184)	98 (2489)	110 (2794)

Measurement is without end panels.

Unit Ventilators

Performance Data—Unit Ventilators

Nominal Capacity Data—Models AV/AH

Unit series ¹		S07 ⁶ , H07 ²	S10 ⁶ , H10 ²	S13 ⁶ , H13 ²	S15 ⁶ , H15 ²	S20 ⁶ , H20 ²
Cooling capacity (Btuh) ³	cfm	750	1000	1250	1500	2000
	2-row	17,900	23,600	31,500	38,800	44,900
	3-row	21,700	33,300	41,100	51,200	50,800
	4-row	27,800	35,600	43,400	56,700	62,200
	5-row ⁶	27,900	35,200	45,400	54,500	—
Steam heat (Btuh) ⁴	cfm	750	1000	1250	1500	2000
	Standard	50,300	75,200	89,000	111,500	140,800
	High	66,500	89,900	112,500	128,500	227,900
Electric heat (Btuh)	Low	20,500	27,300	34,100	41,000	41,000
	High	41,000	54,600	68,300	81,900	81,900
Hot water heat ⁵	1-row	37,000	49,500	57,000	66,000	69,800
	2-row	48,300	62,000	74,100	97,200	96,700
	3-row	56,800	72,000	84,500	97,500	115,000

- All data is for F Vintage units.
- Ceiling unit only.
- 80°F/67°F entering air temperature; 45°F entering water temperature; 10°F water temperature rise; 10 GPM.
- 0°F entering air temperature; 2 PSI steam at 218.5°F.
- 60°F entering air temperature; 160°F entering water temperature; 6 gpm water flow.
- Vertical unit only.

Nominal Capacity Data—Model AZ

Unit series			AZ024	AZ036	AZ044	AZ054
Full load cooling capacity ¹	Total	Btuh	22,100	36,800	44,000	52,100
		Watts	6478	10,786	12,986	15,271
	Sensible	Btuh	15,500	23,800	31,500	35,500
		Watts	4543	6976	9233	10,405
	Efficiency	EER	9.7	9.5	9.4	9.3
Power	kW	2.3	3.9	4.7	5.6	
Part load cooling capacity ²	Total	Btuh	18,000	28,000	36,300	42,700
		Watts	5276	8207	10,640	12,515
	Sensible	Btuh	12,200	19,000	24,900	27,500
		Watts	3576	5569	7298	8060
	Efficiency	EER	12.6	12.4	11.8	11.8
Power	kW	1423	2259	3060	3600	
Steam heat ³	Low capacity (68)	Btuh	52,000	64,000	77,800	77,800
		Watts	15,236	18,752	22,795	22,795
	High capacity (69)	Btuh	85,700	105,000	128,500	128,500
		Watts	25,110	30,765	37,650	37,650
Electric heat	Low	kW	8.0	10.0	12.0	12.0
		MBh	27.3	34.1	41.0	41.0
	High	kW	16.0	20.0	24.0	24.0
		MBh	54.6	68.3	81.9	81.9
Hot water heat ⁴	1-row coil	Btuh	49,500	57,000	66,000	66,000
		Watts	13,390	15,851	18,693	18,693
	2-row coil	Btuh	62,000	74,100	97,200	97,200
		Watts	18,313	21,536	25,959	25,959

- Conditions: Indoor 80°F (27°C) DB / 67°F (19°C) WB, Outdoor 95°F (35°C) DB / 75°F (24°C) WB
- Conditions: Indoor 80°F (27°C) DB / 67°F (19°C) WB, Outdoor 82°F (28°C) DB / 65°F (18°C) WB
- Steam Heating @ 2 psig Steam (13.8 KPa); 60°F (16°C) Entering Air Temperature.
- 60°F (16°C) Entering Air Temperature; 160°F (71°C) Entering Water Temperature; 6 gpm (22.7 Lpm) Water Flow.

Unit Ventilators

Nominal Capacity Data—Model AE

Unit series			AE024	AE036	AE044	AE054
Full load cooling capacity ¹	Total	Btuh	21,100	39,300	43,700	51,200
		Watts	6180	11,520	1,810	15,000
	Sensible	Btuh	15,700	25,500	30,000	34,400
		Watts	4530	7500	8790	10,080
	Efficiency	EER	9.1	9.7	9.1	9.1
Power	kW	2.3	4.1	4.8	5.6	
Part load cooling capacity ²	Total	Btuh	16,900	30,800	35,500	41,600
		Watts	4950	9030	10,410	12,180
	Sensible	Btuh	12,100	20,000	23,800	26,600
		Watts	3540	5850	6990	7770
	Efficiency	EER	11.7	11.7	11.8	11.5
Power	kW	1450	2630	3010	3620	
Full load heating capacity ³	Total	Btuh	20,700	35,000	41,600	49,700
		Watts	6090	10,230	12,180	14,580
	Efficiency	COP	3.0	2.6	2.6	2.5
Power	kW	2.1	3.9	4.6	5.8	
Part load heating capacity ⁴	Total	Btuh	17,700	29,100	36,100	43,000
		Watts	5160	8520	10,560	12,600
	Efficiency	COP	3.3	2.8	3.0	2.8
	Power	kW	1560	3055	3525	4500
Electric heat	Low	kW	8.0	10.0	12.0	12.0
		MBh	27.3	34.1	41.0	41.0
	High	kW	16.0	20.0	24.0	24.0
		MBh	54.6	68.3	81.9	81.9

1. Conditions: Indoor 80°F (27°C) DB / 67°F (19°C) WB, Outdoor 95°F (35°C) DB / 75°F (24°C) WB
2. Conditions: Indoor 80°F (27°C) DB / 67°F (19°C) WB, Outdoor 82°F (28°C) DB / 65°F (18°C) WB
3. Conditions: Indoor 70°F (21°C) DB / 60°F (16°C) WB, Outdoor 47°F (8°C) DB / 43°F (6°C) WB
4. Conditions: Indoor 70°F (21°C) DB / 60°F (16°C) WB, Outdoor 62°F (17°C) DB / 56.5°F (14°C) WB

Nominal Capacity Data—Water Loop at High Indoor Fan Speed—Models AR/ER

Unit series			AR/ER024	AR/ER040	AR/ER048	
Boiler/ tower	Water flow		Gpm	6.5	10.0	12.0
			L/s	0.41	0.63	0.76
	Cooling ¹	Total	Btuh	23,000	39,200	48,100
			Watts	6740	11,490	14,100
		Sensible	Btuh	17,600	28,000	35,900
			Watts	5160	8210	10,520
		Efficiency	EER	13.0	13.5	14.0
		Power	kW	1.8	2.9	3.4
	Nominal Airflow CFM (L/s)			1000 (472)	1250 (590)	1500 (708)
	Heating ²	Total	Btuh	28,500	45,900	56,000
			Watts	8350	13,450	16,410
		Efficiency	COP	4.5	4.2	4.4
		Power	kW	1.8	3.2	3.7
Electric heat	Low	kW	8.0	10.0	12.0	
		MBh	27.3	34.1	41.0	
	High	kW	16.0	20.0	24.0	
		MBh	54.6	68.3	81.9	

1. Based on ASHRAE and ISO 13256-1 conditions of 86°F (30°C) entering water temperature.
2. Based on ASHRAE and ISO 13256-1 conditions of 68°F (20°C) entering water temperature.

Unit Ventilators

Nominal Capacity Data—Water Loop at Medium Indoor Fan Speed—Models AR/ER

Unit series			AR/ER024	AR/ER040	AR/ER048	
Boiler/ tower	Water flow		Gpm	6.5	10.0	12.0
			L/s	0.41	0.63	0.76
	Cooling ¹	Total	Btuh	17,000	27,700	34,600
			Watts	4980	8120	10,140
		Sensible	Btuh	13,400	20,300	26,000
			Watts	3930	5950	7620
		Efficiency	EER	14.7	14.7	15.0
		Power	kW	1.2	1.9	2.3
	Heating ²	Total	Btuh	19,300	33,300	40,300
			Watts	5660	9760	11,810
		Efficiency	COP	4.8	4.4	4.7
		Power	kW	1.2	2.2	2.5
Nominal Airflow CFM (L/s)			750 (354)	1000 (472)	1150 (542)	
Electric heat	Low		kW	8.0	10.0	12.0
			MBh	27.3	34.1	41.0
	High		kW	16.0	20.0	24.0
			MBh	54.6	68.3	81.9

1. Based on ASHRAE and ISO 13256-1 conditions of 86°F (30°C) entering water temperature.

2. Based on ASHRAE and ISO 13256-1 conditions of 68°F (20°C) entering water temperature.

Nominal Capacity Data—Ground Loop at High Indoor Fan Speed—Model GR

Unit series			GR024	GR040	GR048	
Geothermal	Coolant flow		Gpm	6.5	10.0	12.0
			L/s	0.41	0.63	0.76
	Cooling ¹	Total	Btuh	23,800	40,300	49,800
			Watts	6980	11,810	14,600
		Sensible	Btuh	18,100	28,400	36,500
			Watts	5310	8320	10,700
		Efficiency	EER	14.6	15.0	15.6
		Power	kW	1.2	1.9	2.3
	Nominal Airflow CFM (L/s)			1000 (472)	1250 (590)	1500 (708)
	Heating ²	Total	Btuh	17,500	35,100	34,000
			Watts	5130	10,290	9970
		Efficiency	COP	3.3	3.5	3.3
Power		kW	1.6	2.9	3.0	
Electric heat	Low		kW	8.0	10.0	12.0
			MBh	27.3	34.1	41.0
	High		kW	16.0	20.0	24.0
			MBh	54.6	68.3	81.9

1. Based on ASHRAE and ISO 13256-1 conditions of 77°F (25°C) entering temperature of 15% brine solution.

2. Based on ASHRAE and ISO 13256-1 conditions of 32°F (0°C) entering temperature of 15% brine solution.

Unit Ventilators

Nominal Capacity Data—Ground Loop at Medium Indoor Fan Speed—Model GR

Unit series			GR024	GR040	GR048	
Geothermal	Coolant flow		Gpm	6.5	10.0	12.0
			L/s	0.41	0.63	0.76
	Cooling ¹	Total	Btuh	18,300	29,900	37,400
			Watts	5360	8760	10,960
		Sensible	Btuh	14,000	21,500	27,000
			Watts	4100	6300	7910
		Efficiency	EER	19.5	19.3	19.9
		Power	kW	0.9	1.6	1.9
	Nominal Airflow CFM (L/s)			1000 (472)	1250 (590)	1500 (708)
	Heating ²	Total	Btuh	13,600	25,600	27,600
			Watts	3990	7500	8090
		Efficiency	COP	3.5	3.6	3.5
		Power	kW	1.1	2.1	2.3
Electric heat	Low		kW	8.0	10.0	12.0
			MBh	27.3	34.1	41.0
	High		kW	16.0	20.0	24.0
			MBh	54.6	68.3	81.9

1. Based on ASHRAE and ISO 13256-1 conditions of 68°F (20°C) entering temperature of 15% brine solution.
 2. Based on ASHRAE and ISO 13256-1 conditions of 41°F (5°C) entering temperature of 15% brine solution.

PTAC/PTHP Product Summary Chart

Model:

16" × 42"
Angled/Flat Top

16" × 44"
Flat Top

16" × 42"
Top Mounted Hydronic

Type K
Replacement

Enersaver™
Legacy

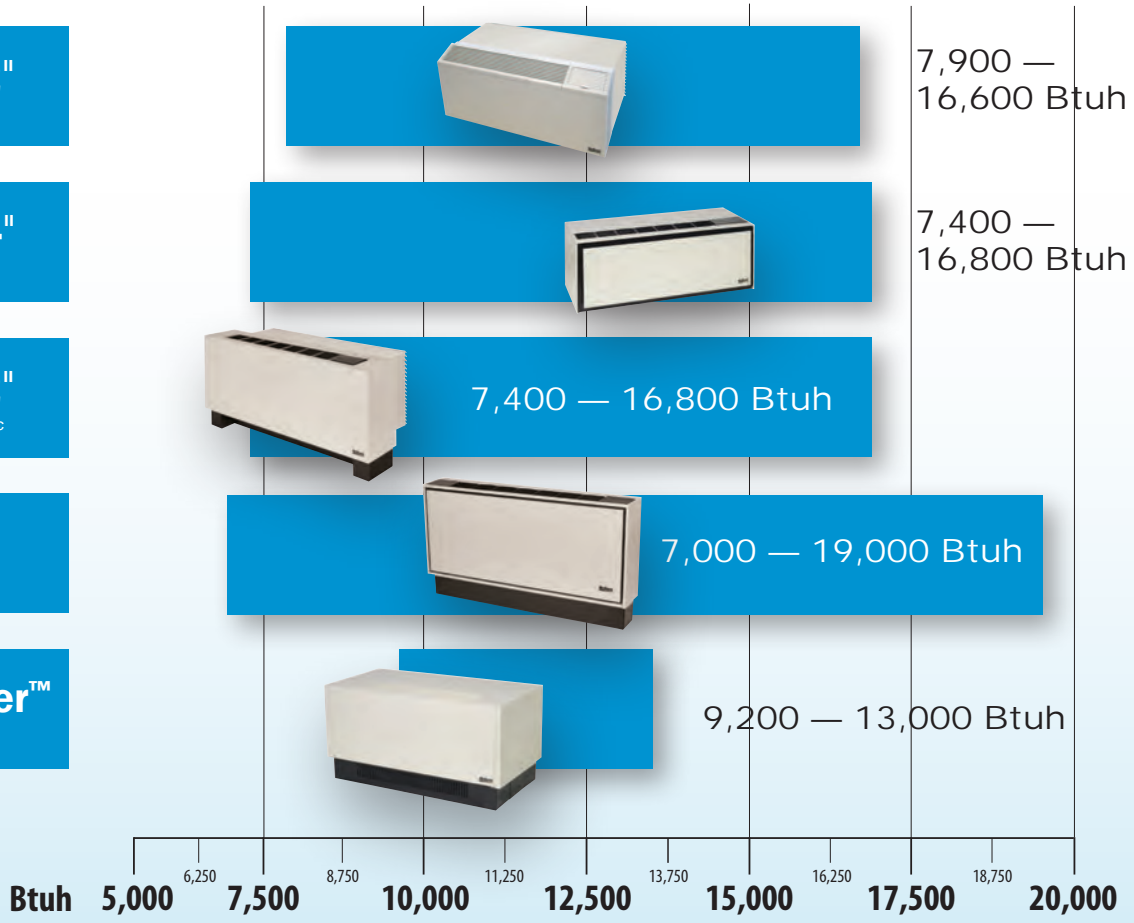

PTAC/PTHP

16" x 42" Applied Packaged Terminal Air Conditioners and Heat Pumps—7,400 to 16,800 Btuh

- Non CFC, R-410A refrigerant
- Ideal for new construction or replacement applications
- Fits standard 16" x 42" wall sleeve
- Broadest selection of features and customizable options allows you to choose the ideal unit for each space in your building
- Top-mounted or Subbase hydronic selections
- Meets or exceeds ASHRAE efficiency standards and COP ratings provide lower operating costs
- Exceptionally quiet, reliable cooling/heating operation to maximize comfort
- Easy to install and maintain
- Engineered and manufactured in the U.S.A.

**For more detail, refer to Catalog 1300.
For the most current information, refer to DaikinApplied.com.**



**Models PDAA and PDHA 16" x 42" Angled Top
(new construction or replacement)**

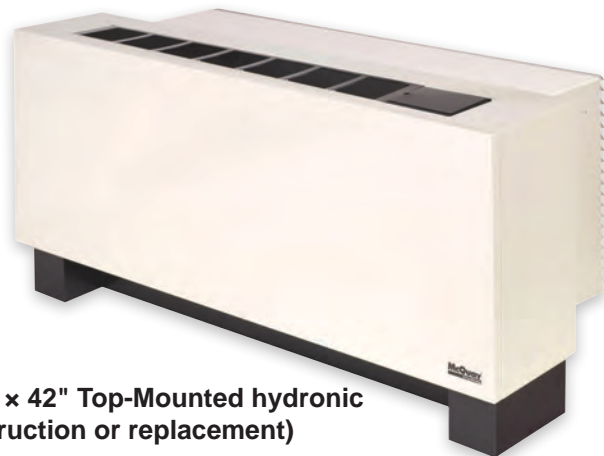

**Model PDAN 16" x 42" Top-Mounted hydronic
(new construction or replacement)**



**Models PDAF and PDHF 16" x 42" Flat Top
(new construction or replacement)**

PTAC/PTHP



Exceptionally Quiet Operation

Sound Comparison

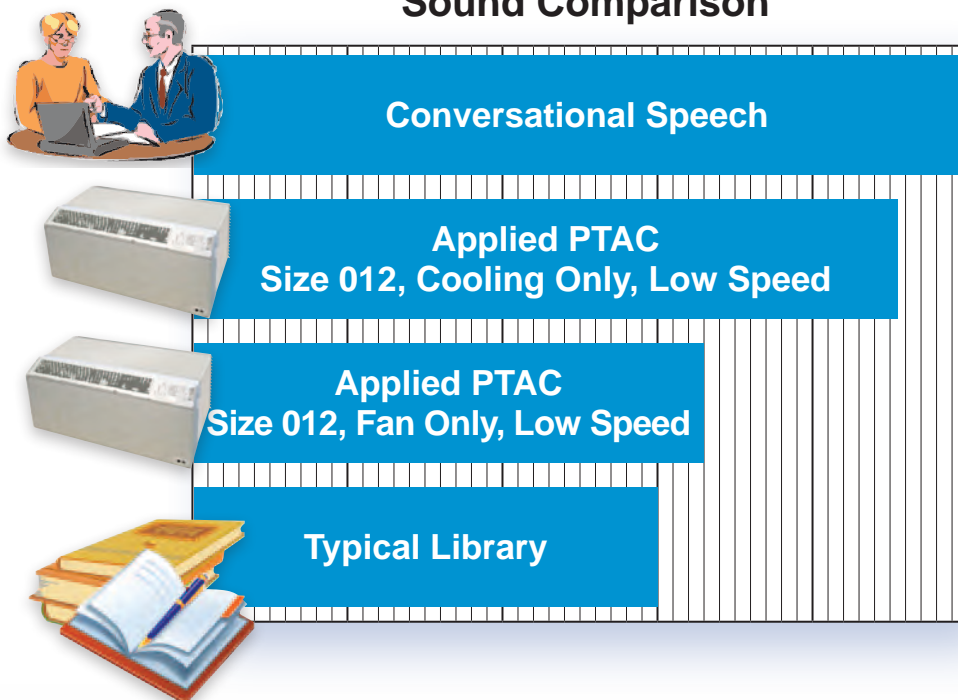

Tangential indoor fan

The GentleFlo™ cross-tangential fan wheel design of Applied PTAC/PTHP units provides whisper quiet operation while delivering maximum airflow required for proper air circulation.

PDAA/PDHA Features and Options

PDAA/PDHA
standard 16" x 42" Angled Top

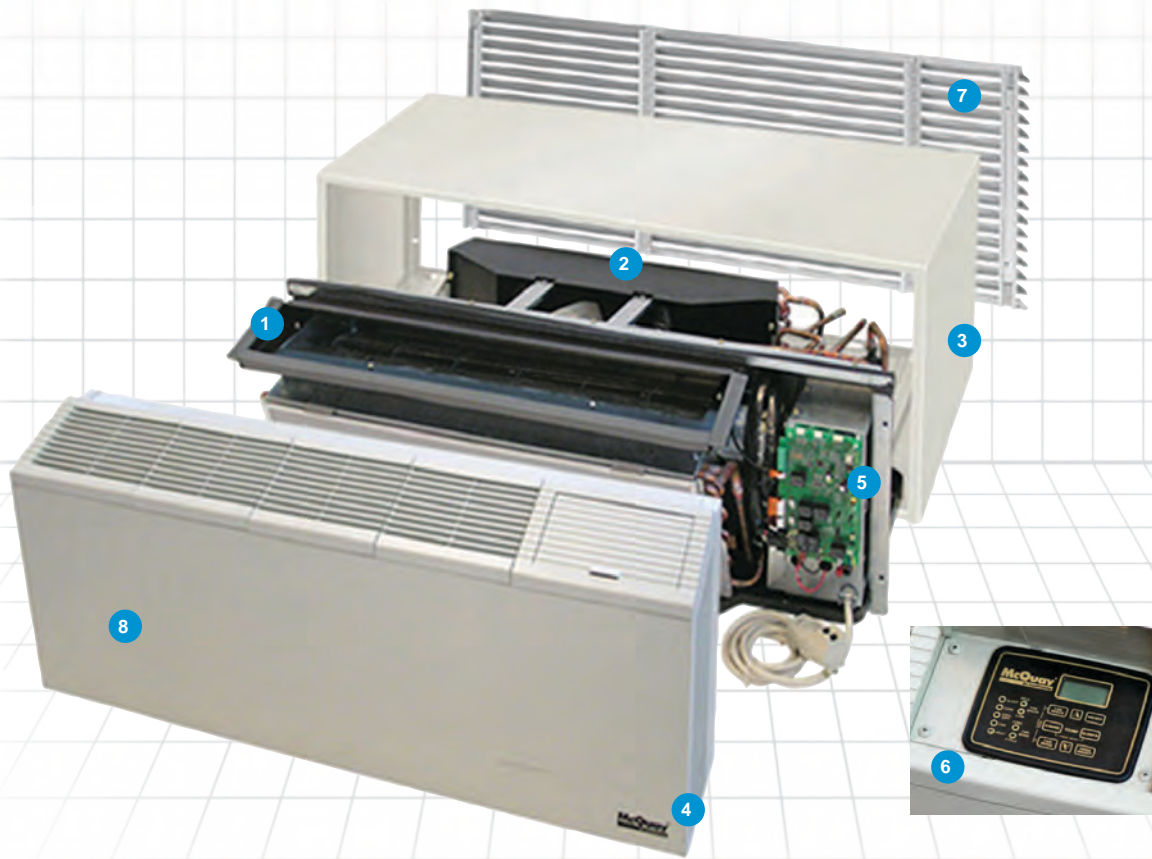

1 Heating/cooling chassis

- Heat pump or cooling with electric and/or hydronic heat

2 Condenser coil

- Optimized heat transfer technology maximizes comfort, reduces energy consumption

3 Wall sleeve, insulated

- Heavy-gauge steel construction
- Powder coat paint finish for maximum corrosion protection

4 Room cabinet

- Heavy-gauge steel construction
- Baked on powder coat paint provides maximum scratch and dent resistance

5 Digital control module

- Provides reliable control and diagnostic information
- Optional premium control with infra-red remote control capability (select models)
- Offers Remote, Wired or Wireless thermostat control option

6 Digital control touchpad

- Easy to use when selecting fan speed, mode of operation, and temperature setting.
- Digital temperature display provides guests with an exact comfort setting to avoid overheating/overcooling
- Fahrenheit or Celsius temperature display
- Standard (non-programmable) or optional premium (7-day programmable)
- Available in Manual (MCO) or Automatic Changeover (ACO)
- Continuous or cycle fan operation
- Automatic room freeze protection

7 Louver (accessory)

- Flush stamped or architectural style
- Anodized aluminum to resist corrosion

8 Front panel

- Heavy gauge steel construction
- Baked on powder coat paint provides maximum scratch and dent resistance

PDAF/PDHF Features and Options

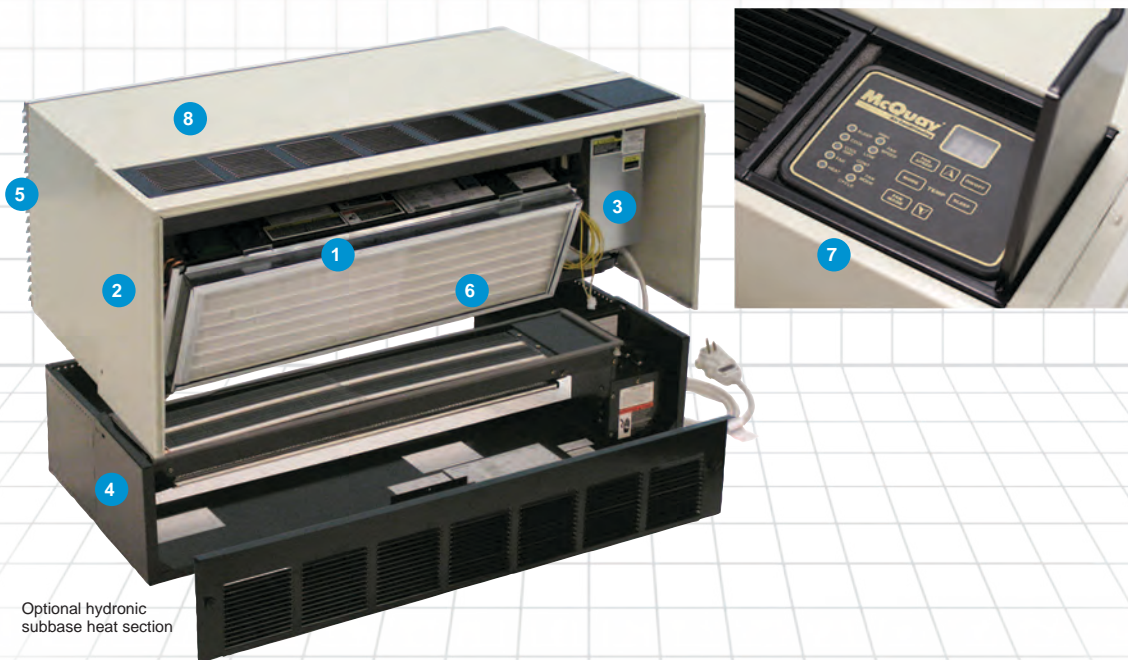
PDAF/PDHF
standard 16" x 42" Flat TopOptional hydronic
subbase heat section**1 Heating/cooling chassis**

- Heat pump or cooling with electric and/or hydronic heat

2 Room cabinet

- Flat top discharge, stamped steel grille
- Front panel raises and can be completely removed for service and chassis access
- Wrap-around cabinet completely encloses the chassis

3 Digital control module

- Provides reliable control and diagnostic information
- Optional premium control with infra-red remote control capability (select models)
- Offers Remote, Wired or Wireless thermostat control option

4 Hydronic subbase heat section (option)

- 2-row, finned/tube coil for either hot water or steam
- Louvered subbase front panel with quick opening latches and hinged for easy access to piping, valves and 1/2" permanent filter

5 Outside air louver

- Heavy-duty, architectural, extruded aluminum to resist weathering
- Option for recessed louver

6 Permanent cleanable filters

- Filters all return air to promote good indoor air quality
- Easy to access and maintain

7 Digital control touchpad

- Easy to use when selecting fan speed, mode of operation, and temperature setting.
- Digital temperature display provides guests with an exact comfort setting to avoid overheating/overcooling
- Fahrenheit or Celsius temperature display
- Standard (non-programmable) or optional premium (7-day programmable)
- Available in Manual or Automatic Changeover
- Continuous or cycle fan operation
- Automatic room freeze protection

8 Wall sleeve, insulated

- Heavy-gauge steel construction
- Powder coat paint finish for maximum corrosion protection

PDAN Features and Options

PDAN with Top-Mounted hydronic heat
standard 16" x 42" Flat Top

Wireless remote control (optional)
Only available on select models

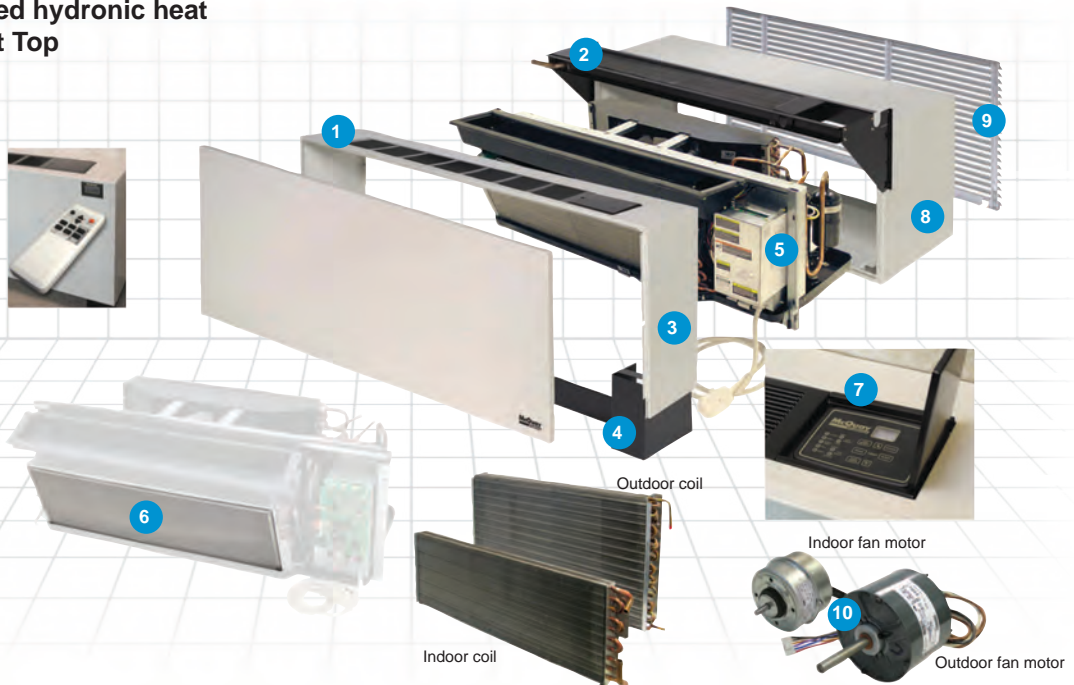
**1 Heavy-duty grille**

- Option for four-way adjustment allows air to be directed where it is needed
- Option for extruded aluminum grille

2 Heating chassis

- Top-mounted hydronic (hot water or steam) heat for easy installation
- Units can be ordered with intermediate electric heat to provide heating in the spring and fall when municipal steam or hot water is not available

3 Room cabinet

- Heavy-gauge steel with powder paint coating for maximum scratch and dent resistance
- Removable for easy access to filters, controls and piping for routine maintenance and service
- Option for custom cabinet colors
- Custom depth for varying wall thicknesses
- Available in front or bottom return configurations

4 Kick plate

- Adjustable height and custom colors for varying floor treatments

5 Digital control module

- Provides reliable control and diagnostic information
- Optional premium control with infrared remote control capability (select models)
- Remote, Wired or Wireless thermostat options

6 Permanent cleanable filter

- Permanent, washable polypropylene mesh filter

7 Digital control touchpad

- Easy to use when selecting fan speed, mode of operation, and temperature setting.
- Digital temperature display provides guests with an exact comfort setting to avoid overheating/overcooling
- Fahrenheit or Celsius temperature display
- Standard (non-programmable) or optional premium (7-day programmable)
- Available in Manual or Automatic Changeover
- Continuous or cycle fan operation
- Automatic room freeze protection

8 Wall sleeve

- Heavy-gauge steel with powder paint coating for maximum scratch, dent and corrosion resistance
- Custom wall sleeve depths available
- Options for brick or panel/curtain wall applications

9 Outside air louver

- Heavy-duty, architectural, extruded aluminum to resist weathering
- Option for recessed louver

10 Separate indoor and outdoor fans

- Provides lower operating costs and quieter operation
- Provides more flexibility for architectural louvers or special condenser air treatments

Replacement Guide

Manufacturer	Model	Wall opening dimensions		Discharge		Return air		Heat type	
		16-1/4" x 42-1/4"		Angled	Flat	Bottom	Front	Electric	Hydronic
		AC	HP						
Amana	PTC	•		•			•	•	•
	PTH		•	•			•	•	
Carrier	52PE	•		•			•	•	
	56PC	•		•			•		
	56PQ	•		•			•	•	
	52SC	•		•			•		
	52SE	•		•			•	•	
	52SQ		•	•			•	•	
Climate Master	PTA	•		•			•	•	
	PTP		•	•			•		•
	PTH	•		•			•	•	
CNI	PC	•		•			•	•	
	PH		•	•			•	•	
Friedrich	PDE	•		•			•	•	
	PDH		•	•			•	•	
	PE	•		•			•	•	
	PH		•	•			•	•	
	TE	•		•			•	•	
	TH		•	•			•	•	
	TW	•		•			•		•
GE	AZ	•	•	•			•	•	
Ice Air	RSK	•			•	•			•
Island Aire	ED	•			•	•		•	•
	NE				•	•		•	•
Daikin	PDE	•		•	•	•		•	•
	PDH		•	•	•	•			
	PSE	•		•		•		•	•
	PSH		•	•		•			
	MQE	•		•	•		•	•	•
	MQR		•	•		•		•	
	MQS	•	•	•	•	•		•	
	NR		•		•	•		•	
	PTAC	•		•			•	•	
PTHP		•	•			•	•		
Singer	N	•			•	•		•	
	NE	•			•	•		•	
	NH		•		•	•			•
	NR		•		•	•		•	
Trane	PTE	•		•			•	•	•
	PTH		•	•			•	•	

= Not applicable
• = Available by Daikin

Not finding what you are looking for? Consult your Daikin representative for information on other replacement PTAC/PTHP products from Daikin.

PDAA/PDHA and PDAF/PDHF Customized Options

Chassis Customization Options - Models PDAA/PDHA and PDAF/PDHF

Description		Unit Size				
Unit Type – PDAA/PDHA and PDAF/PDHF		007	009	012	015	017
Cabinet type	16" x 42" angled top	•	•	•	•	•
	16" x 42" flat top	•	•	•	•	•
Voltage	115/60/1	•	•	n/a	n/a	n/a
	208/230/60/1	•	•	•	•	•
	265/277/60/1	•	•	•	•	n/a
	208/230/60/1 w/standby 115/50/1	•	•	•	•	•
	265-277/60/1 w/standby 115/50/1	•	•	•	•	n/a
	208/208/60/1 w/standby (all sizes)	•	•	•	•	•
Cooling capacity Btuh		7,400	9,100	12,800	14,400	16,800
Heating options						
Electric heater (kW)	2.5	•	•	•	•	•
	3.5	•	•	•	•	•
	5.0	n/a	n/a	•	•	•
Hydronic - hot water or steam		•	•	•	•	•
Hydronic with intermediate electric (PDAA, PDAF and PDAN units only)		•	•	•	•	•
Heat pump		•	•	•	•	n/a
Heat pump with supplemental electric heat		•	•	•	•	n/a
Air flow cfm – high/low speed in heating	380/340	•	•	•	•	580/380
Outside air damper – vent – cfm –high/low speed	50/40	•	•	•	•	70/50
Damper						
Auto damper control (standard with hydronic heat)		•	•	•	•	•
Manual damper control (not available with hydronic heat)		•	•	•	•	•
Indoor air quality (IAQ) boost fan with auto damper		•	•	•	•	•
Unit control	Unit mounted non-programmable	•	•	•	•	•
	Unit mounted programmable	•	•	•	•	•
	Remote thermostat (wired or wireless)	•	•	•	•	•
Seacoast coating package		•	•	•	•	•

Other Customization Options

Custom sleeve

Extended depths, brick stops, or support legs can be added for panel wall or curtain wall applications

ExtendAire™

Cabinet extension to provide balanced cooling/heating in two rooms using one unit (flat top units only)

The Hydronic Experts

Daikin is a leading manufacturer of hydronic heat equipment with a host of configurable options.

- Cooling only mode with hydronic heat
- Cooling only mode with hydronic heat and supplemental electric heat
- Top mounted hydronic coil (steam or hot water)
- Subbase hydronic (steam or hot water)



Hydronic Subbase
For PDAA and PDAF series only

PTAC/PTHP

Performance Data - Models PDAA/PDHA, PDAF/PDHF, PDAN and PDAE/PDHE

Cooling Model													
		007			009			012		015		017	
Cooling	BTUH	7400			9100			12800		14400		16800	
	Sensible BTUH	6500			7500			9000		9600		11700	
	EER	11.6			11.1			10.0		9.5		9.3	
	Volts	115	208/230	265	115	208/230	265	208/230	265	208/230	265	208/230	
	FLA	7.43	4.07	3.34	9.33	5.45	4.04	7.15	6.09	8.21	6.69	10.03	
	Watts	679	679	679	850	850	850	1306	1306	1532	1532	1806	
Electric Heat	Volts	—	208/230	265	—	208/230	265	208/230	265	208/230	265	208/230	
	2.5 KW	KW	—	2.0/2.5	—	—	2.0/2.5	—	2.0/2.5	—	2.0/2.5	—	2.0/2.5
		Amps	—	9.7/10.7	—	—	9.7/10.7	—	9.7/10.7	—	9.7/10.7	—	9.7/10.7
	3.5 KW	KW	—	2.7/3.4	3.3	—	2.7/3.4	3.3	2.7/3.4	3.3	2.7/3.4	3.3	2.7/3.4
		Amps	—	13.2/14.6	12.3	—	13.2/14.6	12.3	13.2/14.6	12.3	13.2/14.6	12.3	13.2/14.6
	5.0 KW	KW	—	—	—	—	—	—	4.0/4.9	4.5	4.0/4.9	4.5	4.0/4.9
Amps		—	—	—	—	—	—	19.4/21.5	16.8	19.4/21.5	16.8	19.4/21.5	
Hydronic Heat	Valve & Fan Motor Amps	0.74	0.41	0.32	0.74	0.41	0.32	0.41	0.32	0.41	0.32	0.47	
	Hot Water BTUH Steam BTUH	18,400/15,600 22,400/22,300			18,400/15,600 22,400/22,300			18,400/15,600 22,400/22,300		18,400/15,600 22,400/22,300		23,200/16,400 27,900/23,300	
Heat Pump Model (Not Applicable for PDAN)													
Cooling	Qt, BTUH	7400			9200			12700		14200		—	
	Qs, BTUH	6500			7500			9000		9500		—	
	EER	11.8			11.3			10.2		9.8		—	
	Volts	115	208/230	265	115	208/230	265	208/230	265	208/230	265	—	
	FLA	7.43	4.07	3.34	9.33	5.45	4.04	7.15	6.09	8.21	6.69	—	
	Watts	679			893			1296		1511		—	
Reverse Cycle Heat	BTUH	6800			8500			12400		14000		—	
	COP	3.30			3.30			3.10		3.00		—	
	Volts	115	208/230	265	115	208/230	265	208/230	265	208/230	265	—	
	FLA	7.43	4.07	3.34	9.33	5.45	4.04	7.15	6.09	8.21	6.69	—	
	Watts	623			755			1211		1415		—	
Electric Heat													
	Volts (7)	115	208/230	265	115	208/230	265	208/230	265	208/230	265	208/230	
Min Circuit Ampacity	2.5 KW	—	14.3	—	—	14.3	—	14.3	—	14.3	—	14.3	
	3.5 KW	—	19.3	16.4	—	19.3	16.4	19.3	16.4	19.3	16.4	19.3	
	5.0 KW	—	—	—	—	—	—	28.3	22.2	28.3	22.2	28.3	
	Hydronic Heat	8.69	4.77	3.89	11.06	6.49	4.77	8.48	7.22	9.8	7.97	12.1	
Time Delay Fuse	2.5 KW	—	15	—	—	15	—	15	—	15	—	15	
	3.5 KW	—	20	20	—	20	20	20	20	20	20	20	
	5.0 KW	—	—	—	—	—	—	30	25	30	25	30	
	Hydronic Heat	15			15			15		15		15	
NEMA Receptacle	2.5 KW	—	6-15R	—	—	6-15R	—	6-15R	—	6-15R	—	6-15R	
	3.5 KW	—	6-20R	7-20R	—	6-20R	7-20R	6-20R	7-20R	6-20R	7-20R	6-20R	
	5.0 KW	—	—	—	—	—	—	6-30R	7-30R	6-30R	7-30R	6-30R	
	Hydronic Heat	5-15R	6-15R	7-20R	5-15R	6-15R	7-20R	6-15R	7-20R	6-15R	7-20R	6-15R	
		High	Low	High	Low	High	Low	High	Low	High	Low	High/Low	
Airflow	Cool	360	330	360	330	360	330	360	330	360	330	540/360	
	Heat	380	340	380	340	380	340	380	340	380	340	550/380	
	Vent	50	40	50	40	50	40	50	40	50	40	70/50	

- Notes: (1) Based on ASHRAE and AHRI test conditions of 95°F DB/75°F WB outside, 80°F DB/67°F WB inside.
 (2) Based on ASHRAE and AHRI test conditions of 47°F DB outside, 70°F DB inside.
 (3) Electric Resistance Heat Watts x 3.41 = Btuh. Electric Heating Watts and Amps include Indoor Fan Motor.
 (4) Water – Based on ASHRAE and AHRI test conditions of 200°F EWT, 180°F LWT, 70°F EAT with a 1.8 gpm flow rate.
 (5) 90 cfm with Power Vent Option.
 (6) Cooling Full Load Amps includes Compressor, IDF and ODF FLA's.
 (7) Electric Heat MCA, Time Delay Fuse and NEMA Receptacle data are based on 240V and 277V.

PTAC/PTHP

Unit Weights*

Model	007	009	012	015	017
16" x 42" (angled) PDAA (chassis) lb (kg)	129.5 (58.7)	137.0 (62.1)	137.9 (62.6)	145.6 (66.0)	150.6 (68.3)
*16" x 42" (angled) PDAA (packaged) lb (kg)	144.5 (65.5)	152.0 (68.9)	152.9 (69.4)	160.6 (72.8)	165.6 (75.1)
16" x 42" (angled) PDHA (chassis) lb (kg)	129.5 (58.7)	137.0 (62.1)	137.9 (62.6)	145.6 (66.0)	—
*16" x 42" (angled) PDHA (packaged) lb (kg)	131.0 (59.4)	138.5 (62.8)	139.9 (63.5)	147.1 (66.7)	—
16" x 42" (flat) PDAF (chassis) lb (kg)	129.5 (58.7)	137.0 (62.1)	137.9 (62.6)	145.6 (66.0)	150.6 (68.3)
*16" x 42" (flat) PDAF (packaged) lb (kg)	144.5 (65.5)	152.0 (68.9)	152.9 (69.4)	160.6 (72.8)	165.6 (75.1)
16" x 42" (flat) PDHF (chassis) lb (kg)	131.0 (59.4)	138.5 (62.8)	139.9 (63.5)	147.1 (66.7)	—
*16" x 42" (flat) PDHF (packaged) lb (kg)	146.0 (66.1)	153.5 (69.6)	154.4 (70.0)	162.1 (73.5)	—
*16" x 44" PDHE (packaged) lb (kg)	131.0 (59.4)	138.5 (62.8)	139.4 (63.2)	147.1 (66.7)	—
*16" x 44" PDAE (packaged) lb (kg)	129.5 (58.7)	137.0 (62.1)	137.9 (62.6)	145.6 (66.0)	148.8
16" x 44" PDHE (chassis) lb (kg)	116.0 (52.6)	123.5 (56.0)	124.4 (56.4)	132.1 (59.9)	—
16" x 44" PDAE (chassis) lb (kg)	114.5 (51.9)	122.0 (55.3)	122.9 (55.7)	130.6 (59.2)	135.8

* Includes chassis and cabinet assembly (wall sleeve ships separate).

Dimensional Data

PDAA/PDHA standard 16" x 42" Angled Top

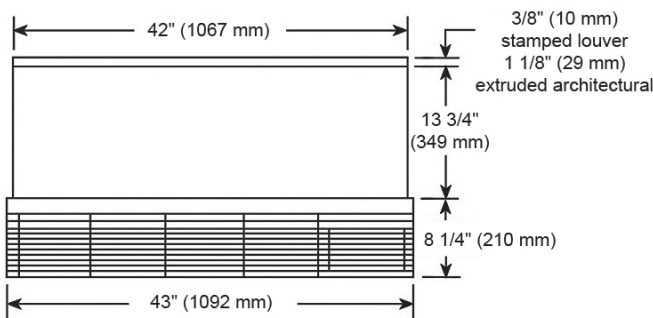

Top View

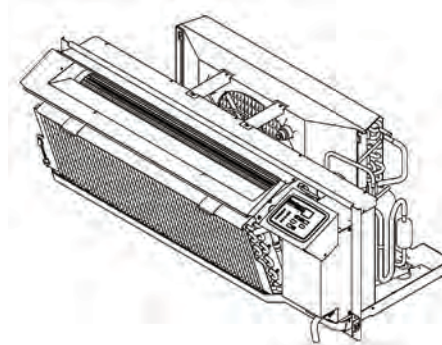

NOTE: Unit pictured with subbase installed. Subbase is optional on 208V/230V units. Subbase is standard on all 265V and units with hydronic heat.

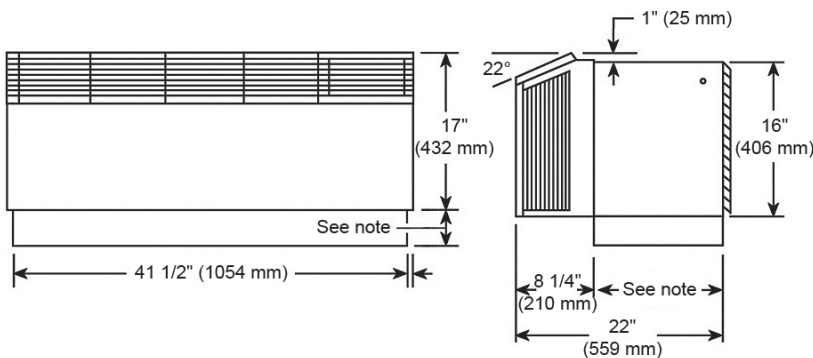

Front View

Side View

Dimensional Data

PDAF/PDHF standard 16" x 42" Flat Top

Cabinet Assembly & Wall Sleeve

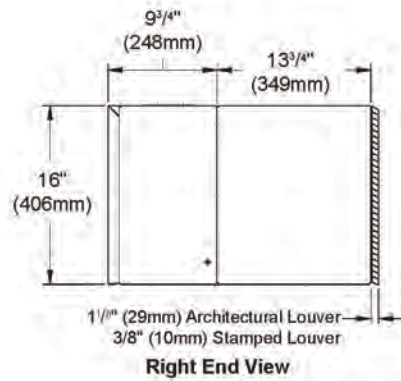
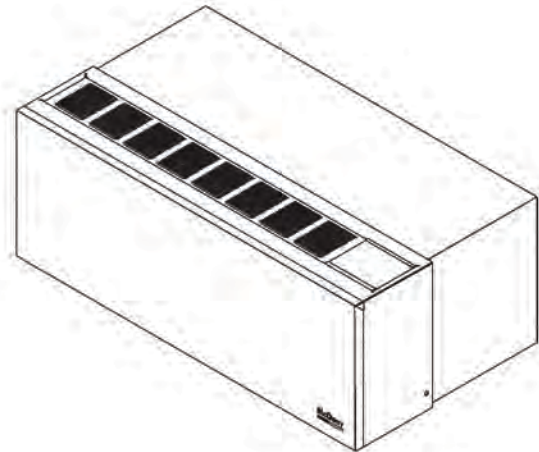
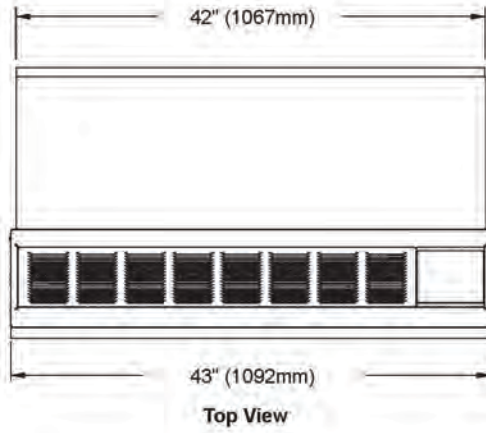

Front View

Right End View

Chassis

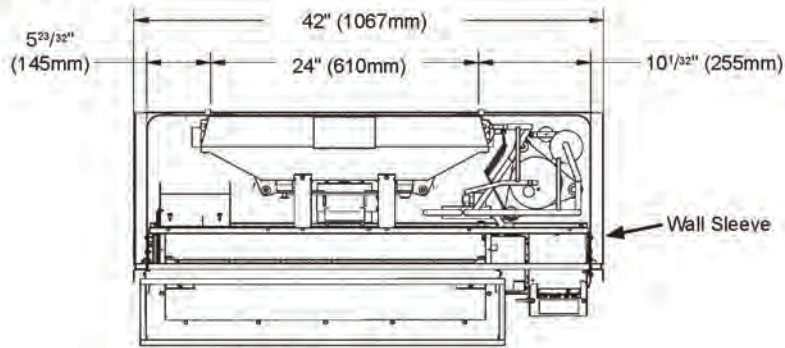

Top View

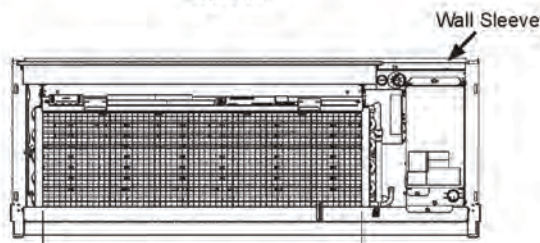

Front View

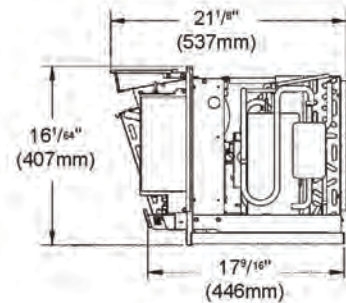

Right End View without Wall Sleeve

Dimensional Data

PDAN standard 16" x 42" Flat Top

Wall Sleeve, Cabinet & Louver

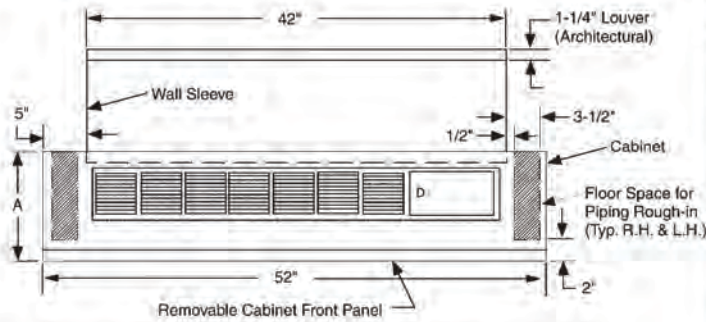

1 1/4" RECESS FOR ARCHITECTURAL LOUVER		
"A" - IN. (MM)	"D" - IN. (MM)	"B" - IN. (MM)
18 1/4 (476)	13 1/4 (349)	4 1/4 - 5 1/4 (121-146)
17 1/4 (451)	13 1/4 (349)	5 1/4 - 6 1/4 (146-171)
16 1/4 (425)	13 1/4 (349)	6 1/4 - 7 1/4 (171-197)
15 1/4 (400)	13 1/4 (349)	7 1/4 - 8 1/4 (197-222)
14 1/4 (375)	13 1/4 (349)	8 1/4 - 9 1/4 (222-248)
13 1/4 (349)	13 1/4 (349)	9 1/4 - 10 1/4 (248-273)
12 1/4 (324)	13 1/4 (349)	10 1/4 - 11 1/4 (273-298)
11 1/4 (298)	13 1/4 (349)	11 1/4 - 12 1/4 (298-324)
10 1/4 (273)	13 1/4 (349)	12 1/4 - 13 1/4 (324-349)
10 1/4 (273)	14 1/4 (375)	13 1/4 - 14 1/4 (349-375)
10 1/4 (273)	15 1/4 (400)	14 1/4 - 15 1/4 (375-400)
10 1/4 (273)	16 1/4 (425)	15 1/4 - 16 1/4 (400-425)
10 1/4 (273)	17 1/4 (451)	16 1/4 - 17 1/4 (425-451)

Standard Size Wall Sleeve

Note: Electrical rough-in should be located behind kickplate (removable front) and below wall sleeve.

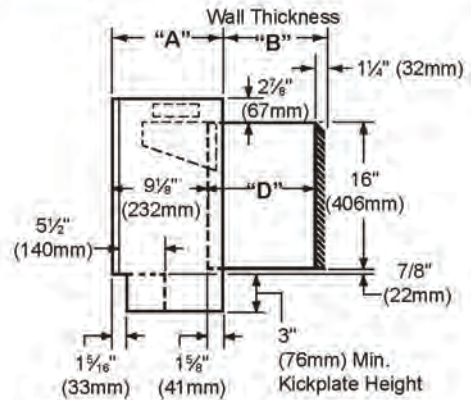
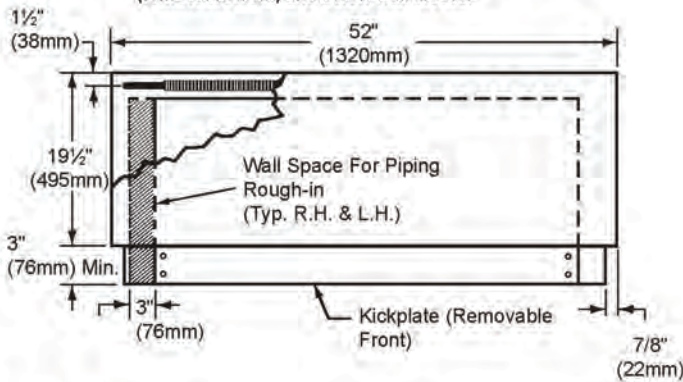

Chassis

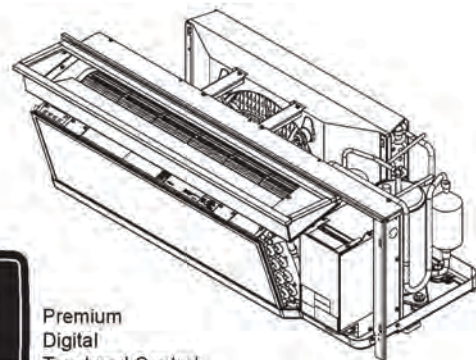
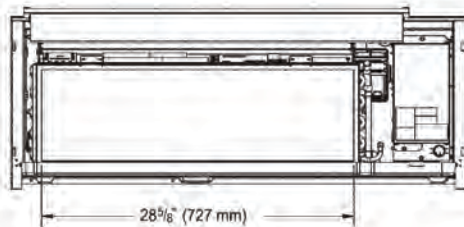
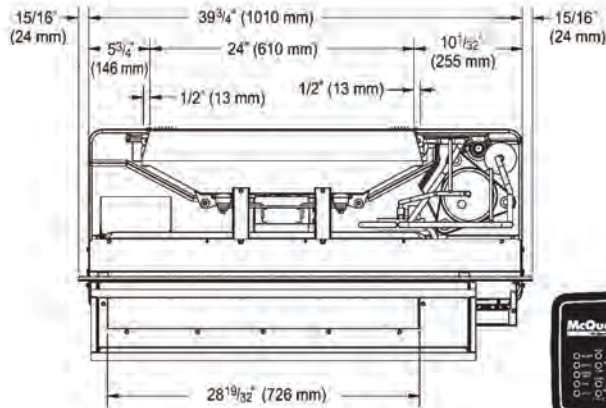

Premium Digital Touchpad Control

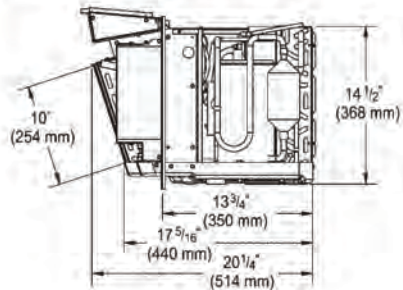

16" x 44" Model PDAE/PDHE Applied Packaged Terminal Air Conditioners and Heat Pumps—7,400 to 16,800 Btuh

- Ideal for replacement applications or new construction
- Fits 16" x 44" wall sleeve
- Broadest selection of features and customizable options allows you to choose the ideal unit for each space in your building
- Subbase hydronic selections
- Meets or exceeds ASHRAE efficiency standards and COP ratings to provide lower operating costs
- Exceptionally quiet, reliable cooling/heating operation maximizes comfort
- Easy to install and maintain
- Engineered and manufactured in the U.S.A.

For more detail, refer to Catalog 1301.

For the most current information, refer to DaikinApplied.com.

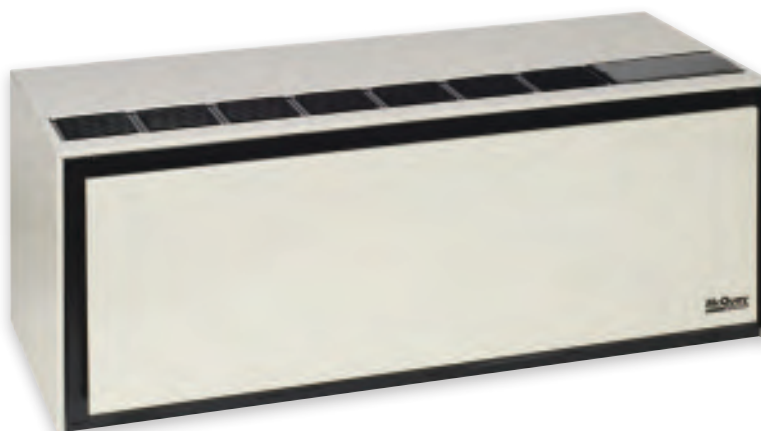

Models PDAE and PDHE
16" x 44" flat top replacement for PMES, PMRS, EA & RS

PDAE/PDHE Features and Options

PDAE/PDHE 16" x 44" Flat Top

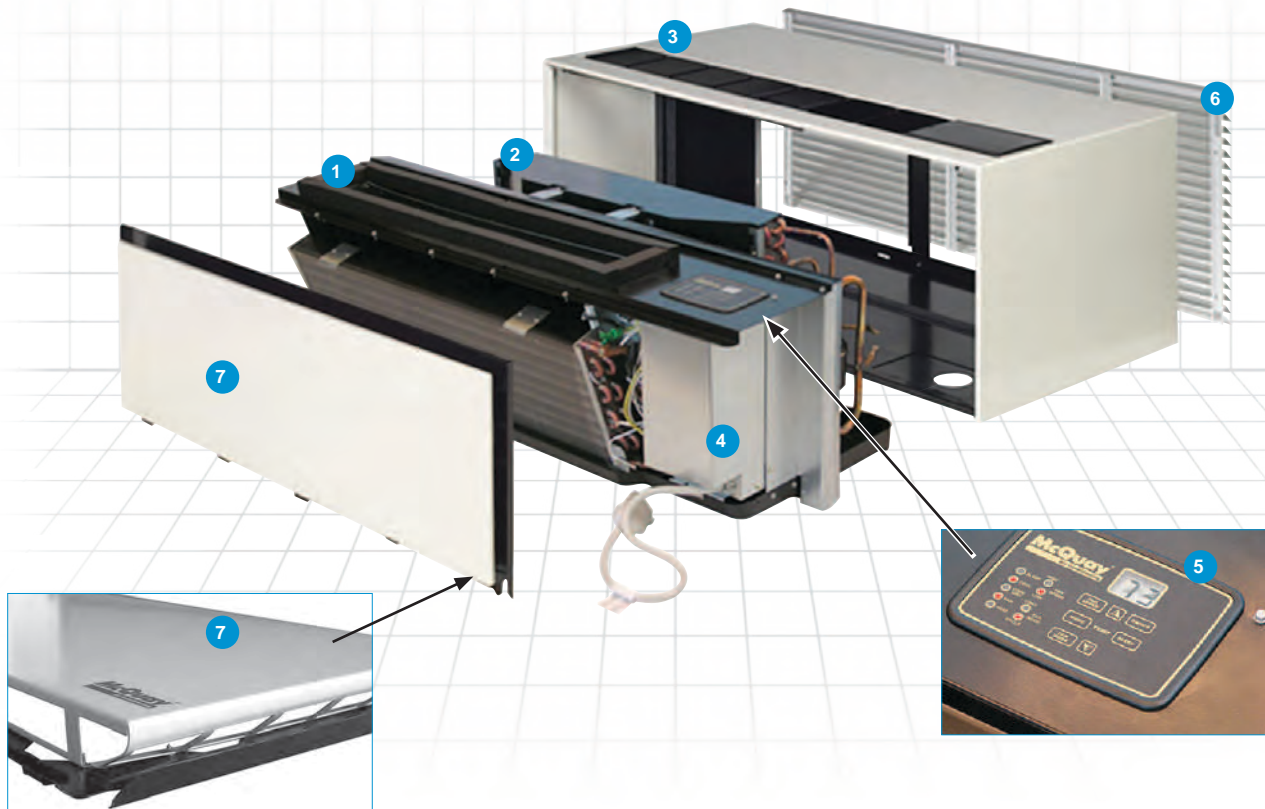
**1 Heating/cooling chassis**

- Heat pump or cooling with electric and/or hydronic heat

2 Condenser coil

- Optimized heat transfer technology maximizes comfort, reduces energy consumption

3 Combination room cabinet and wall sleeve

- Heavy-gauge steel construction
- Baked on powder coat paint provides maximum scratch and dent resistance, corrosion protection

4 Digital control module

- Provides reliable control and diagnostic information
- Optional premium control with infra-red remote control capability (select models)
- Offers Remote, Wired or Wireless thermostat control option

5 Digital control touchpad

- Easy to use when selecting fan speed, mode of operation, and temperature setting.
- Digital temperature display provides guests with an exact comfort setting to avoid overheating/overcooling
- Fahrenheit or Celsius temperature display
- Standard (non-programmable) or optional premium (7-day programmable)
- Available in Manual or Automatic Changeover
- Continuous or cycle fan operation
- Automatic room freeze protection

6 Louver (accessory)

- Flush stamped or architectural style
- Anodized aluminum to resist corrosion

7 Front panel

- Heavy gauge steel construction
- Baked on powder coat paint provides maximum scratch and dent resistance

PDAE/PDHE Customized Options

Chassis Customization Options

Description		Unit Size				
Unit Type – PDAE/PDHE		007	009	012	015	017
Cabinet type	16" x 44" top mount hydronic	•	•	•	•	•
	16" x 44" flat top replacement	•	•	•	•	•
Voltage	115/60/1	•	•	N/A	N/A	N/A
	208/230/60/1	•	•	•	•	•
	265/277/60/1	•	•	•	•	N/A
	208/230/60/1 w/standby 115/60/1	•	•	•	•	•
	265/277/60/1 w/standby 115/60/1	•	•	•	•	N/A
	208/208/60/1 w/standby (all sizes)	•	•	•	•	•
Cooling capacity Btuh		7,400	9,100	12,800	14,400	16,800
Heating options						
Electric heater (kW)	2.5	•	•	•	•	•
	3.5	•	•	•	•	•
	5.0	N/A	N/A	•	•	•
Hydronic - hot water or steam		•	•	•	•	•
Heat pump		•	•	•	•	•
Heat pump with supplemental electric heat		•	•	•	•	•
Air flow cfm – high/low speed in heating	380/340	•	•	•	•	550/380
Outside air damper – vent – cfm –high/low speed	50/40	•	•	•	•	70/50
Damper						
Auto damper control (standard for most hydronic heat)		•	•	•	•	•
Manual damper control (not available for most hydronic heat)		•	•	•	•	•
Indoor air quality (IAQ) boost fan with auto damper		•	•	•	•	•
Unit control	Unit mounted non-programmable	•	•	•	•	•
	Unit mounted programmable	•	•	•	•	•
	Remote (Wired or Wireless), Hand Held IR	•	•	•	•	•
Seacoast coating package		•	•	•	•	•

N/A = Not Applicable.

For illustration purposes only. Not all options available with all models.
Consult a Daikin Sales Representative for details and availability.

Other Customization Options

Hydronic coils

- Factory-installed in subbases

The Hydronic Experts

Daikin is a leading manufacturer of hydronic heat equipment, both hot water and steam, with a host of configurable options.

- Cooling only mode with hydronic heat
- Cooling only mode with hydronic heat and supplemental electric heat
- Subbase hydronic (steam or hot water)



Hydronic Subbase

Dimensional Data

PDAE/PDHE 16" x 44" Flat Top

Air conditioner with electric heat or heat pump with electric heat

Wall Sleeve, Cabinet and Louver

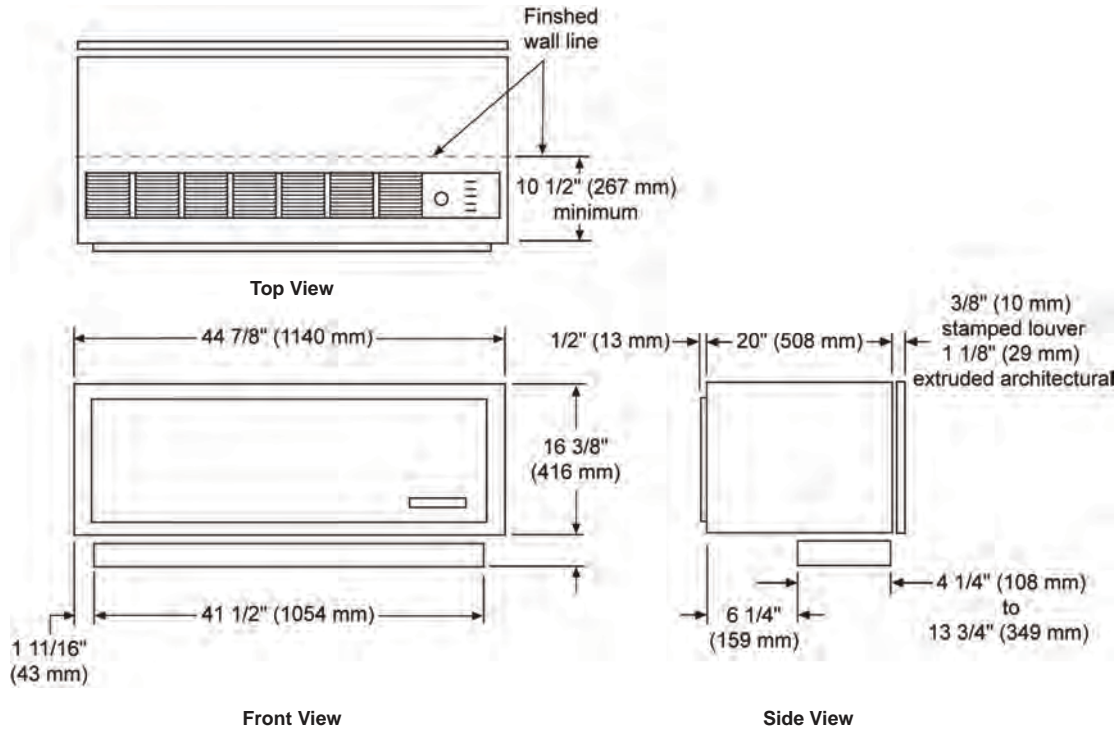

Chassis

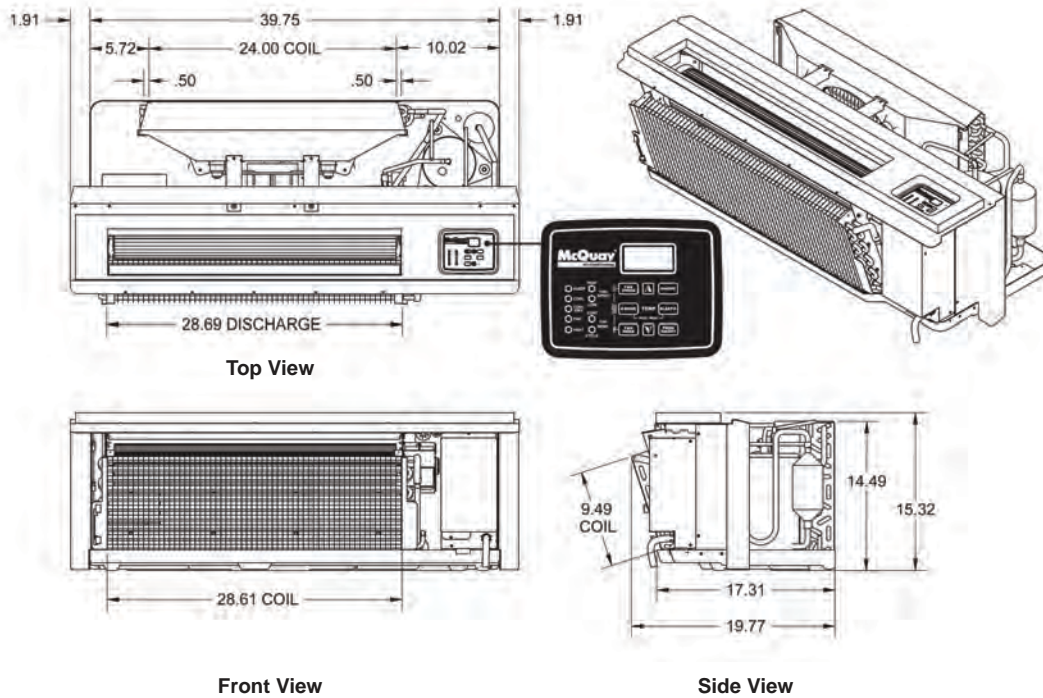

Legacy Incremental® and Packaged Terminal Conditioners and Heat Pumps

- Proven institutional grade design and heavy duty construction
- Fits exactly into existing wall sleeves to reduce renovation costs
- Updated performance adds comfort and reduces operating costs
- Factory test, check and run program for reliable start-up
- Easy maintenance can be done by your own staff
- UL, CSA, and CE agency listings
- R-410A refrigerant

For more detail, refer to Catalog 1302.

For the most current information, refer to DaikinApplied.com.

Type K (PKES, PKHS)

Incremental® Room Conditioner

- 13-11/16" x 36-1/4" (Type K) wall sleeve dimensions
- 15-7/8" x 46-1/4" (Type KG) wall sleeve dimensions
- Electric resistance (2.4–6.6 kW) or hydronic (steam or hot water) heat
- Cooling capacities from 6,800 to 20,000 Btuh
- Designed for long life

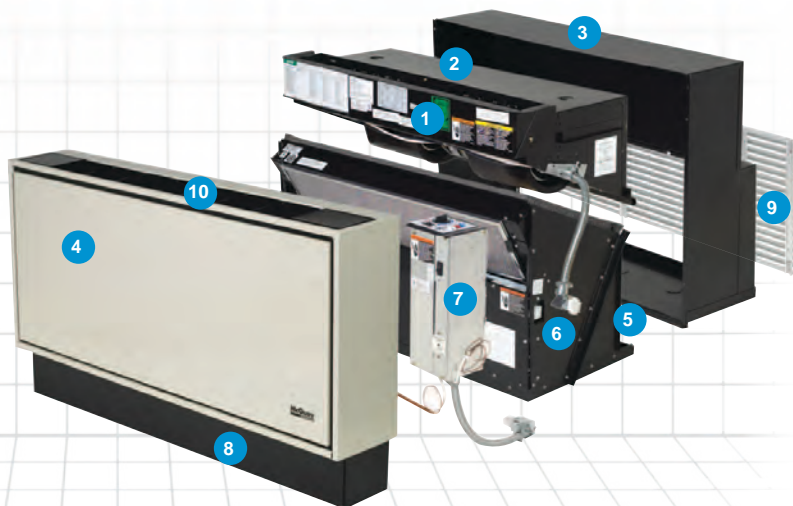

1 Centrifugal fans

- Quieter and able to overcome more external static pressure than propeller fans
- Allows more flexible options for architectural louvers or special condenser air treatments

2 Heating section

- Option for electric resistance or hydronic (steam or hot water) heat

3 Wall sleeve

- Heavy-gauge steel construction
- Minimizes vibration for quieter operation

4 Room cabinet

- Heavy-gauge steel with powder paint coating provides maximum scratch and dent resistance and minimizes vibration for quieter operation

5 Motorized outside air damper

- Opens when unit is operating to bring in outside air for improved indoor air quality (IAQ)
- Closes when unit is idle to prevent drafts

6 Cooling chassis

- Energy efficient, reliable rotary compressor
- Compressor is vibration isolated for quieter operation
- Dry-pan operation minimizes condensate

7 Electro-mechanical controls

- Reliable and easy to operate
- Easy to read with color coding and raised lettering for the visually impaired
- Remote thermostat option available

8 Adjustable kickplate

- Adjusts up or down to accommodate new floor coverings

9 Outside air louver

- Heavy-duty, architectural extruded aluminum to resist weathering

10 Heavy-duty grille

- Four-way adjustment allows air to be directed where it is needed



EnerSaver™ Model

PNES - Air conditioner with electric or hydronic heat

PNHS - Heat Pump with electric heat

- 16" x 37-½" or 16" x 41-½" wall sleeve dimensions
- Replaces Series 16 and Type 45 units
- Combined heating and cooling chassis
- Cooling capacities from 9,500 to 13,000 Btuh
- Electric or hydronic heat
- Available voltages—208, 230 and 265V
- EERs up to 9.8 and COP's up to 3.0 on reverse cycle heat pump models
- Designed for long life

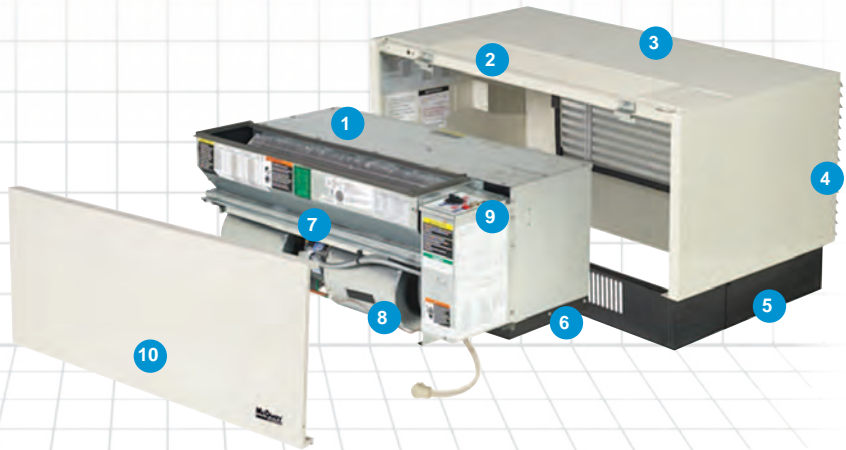

1 Ventilation control

- Manual damper standard on electric and heat pump chassis
- Motorized damper standard on hydronic chassis

2 Heavy-duty grille

- Factory-mounted, "pencil proof" bar stock discharge grille

3 Room cabinet/wall sleeve

- Heavy gauge steel with powder paint coating provides maximum scratch and dent protection and resists corrosion

4 Outside air louver

- Factory-mounted extruded aluminum to resist weathering

5 Subbase

- Heavy-duty steel with powder coated paint to resist corrosion

6 Base pan

- One-piece base pan and one-piece bulkhead assure weather tightness and water integrity

7 Fan motors

- Both indoor and outdoor fan motors are PSC for superior quality and greater reliability

8 Indoor fan wheels

- Large diameter to provide improved airflow and quiet operation

9 Electromechanical controls

- Reliable and easy to operate. Easily adaptable to energy management systems

10 Front access panel

- Heavy gauge steel with powder paint coating provides maximum scratch and dent resistance and minimizes vibration for quieter operation

Replacement Guide

Old model description	Wall opening dimensions (in)	Current model description
AAF EnerSaver A/C—Type ENR	16 x 37-1/2 or 16 x 41-1/2	Daikin EnerSaver PTAC—PNES ¹
AAF EnerSaver A/C—Type WY ¹	16 x 37-1/2 or 16 x 41-1/2	Daikin EnerSaver PTAC—PNES ¹
AAF EnerSaver Heat Pump—Type ENH	16 x 37-1/2 or 16 x 41-1/2	Daikin EnerSaver PTHP—PNHS ¹
AAF EnerSaver Heat Pump—Type YY ¹	16 x 37-1/2 or 16 x 41-1/2	Daikin EnerSaver PTHP—PNHS ¹
American Standard Type 45 A/C	16 x 37 or 16 x 42	Daikin EnerSaver PTAC—PNES ²
American Standard Type 45 HP	16 x 37 or 16 x 42	Daikin EnerSaver PTAC—PNHS ²
Daikin—Type MEK	13-11/16 x 36-1/4 or 15-7/8 x 46-1/4	Daikin Type K, Cooling Chassis—PKES
Daikin—Type MHK	13-11/16 x 36-1/4 or 15-7/8 x 46-1/4	Daikin Type K, Heating Chassis—PKHS
Daikin—Type MQP	13-11/16 x 36-1/4 or 15-7/8 x 46-1/4	Daikin Type K, Heating Chassis—PKHS; Cooling Chassis—PKES
Daikin—Type EK	13-11/16 x 36-1/4	Daikin Type K, Heating Chassis—PKHS; Cooling Chassis—PKES
Daikin—Type RK	13-11/16 x 36-1/4	Daikin Type K, Heating Chassis—PKHS; Cooling Chassis—PKES
Daikin—Type K	13-11/16 x 36-1/4	Daikin Type K, Heating Chassis—PKHS; Cooling Chassis—PKES
Daikin—Type EKG	15-7/8 x 46-1/4	Daikin Type K, Heating Chassis—PKHS; Cooling Chassis—PKES
Daikin—Type KG	15-7/8 x 46-1/4	Daikin Type K, Heating Chassis—PKHS; Cooling Chassis—PKES

1. AAF Series 16. For other AAF, Singer, or Remington models, call your local Daikin Representative or (800) 432-1342
 2. Includes fan motor.

Performance Data

Type K (PKES/PKHS)

Unit Size		007				009			012			017			019		
Cooling	Btuh ¹	7300				9500			11,600			16,700			18,700		
	Watts	770				1060			1380			2012			2300		
	EER (Btuh/Watts)	9.4				8.9			8.4			8.3			8.1		
Airflow (CFM)	High/Low Speed	290/210				290/210			290/210			530/470			530/470		
Ventilation	CFM	70				70			70			135			135		
Electric Heaters	Voltage	115	208	230	265	208	230	265	208	230	265	208	230	265	208	230	
	"L" Heater	Amps ²	—	16.3	13.9	12.1	20.2	18.3	15.8	20.2	18.3	15.8	32.7	31.7	27.6	32.7	—
		Watts	—	3400	3200	3200	4200	4200	4200	4200	4200	4200	6800	7300	7300	6800	—
	"M" Heater	Amps ²	—	—	10.4	—	16.3	13.9	12.1	16.3	13.9	12.1	24.5	23.9	20.8	24.5	—
		Watts	—	—	—	—	3400	3200	3200	3400	3200	3200	5100	5500	5500	—	—
	"S" Heater	Amps ²	—	—	—	—	12.5	—	—	12.5	—	9.8	—	—	—	—	—
Watts		—	—	—	—	2600	—	—	2600	—	2600	—	—	—	—	—	
Hydronic Heat (Btuh) ³	Hot Water	13,300				13,300			13,300			16,500			16,500		
	Steam	16,500				16,500			16,500			23,500			23,500		
Minimum Circuit Ampacity	"L" Heater	—	20.9	17.8	15.4	25.7	23.3	20.1	25.7	23.3	20.1	41.6	40.4	35.2	41.6	—	
	"M" Heater	—	—	1.25	—	20.9	17.8	15.4	20.9	17.8	15.4	31.4	30.6	26.7	31.4	—	
	"S" Heater	—	—	—	—	16.1	16.1	—	16.1	16.1	12.6	—	—	—	—	—	
	Hydronic	10.0	4.9	4.9	4.3	7.5	7.5	5.2	9.0	9.0	7.2	13.9	13.9	13.9	13.9	13.9	
Time Delay Fuse, or if under 250 V Type HACR	"L" Heater	—	25	20	20	30	25	20	30	25	20	45	45	35	45	—	
	"M" Heater	—	—	15	—	25	20	20	25	20	20	35	35	30	35	—	
	"S" Heater	—	—	—	—	20	—	—	20	—	15	—	—	—	—	—	
	Hydronic	15				15			15			20			20		

1 Based on ASHRAE and AHRI test conditions of 95°F DB / 75°F WB outdoors, 80°F DB / 67°F WB inside.
 2 Includes fan motor.
 3 Based on 200°F EWT, 180°F LWT; 2psig steam—65°F EAT. Tested and rated in accordance with AHRI Standards 310 and 380.

EnerSaver (PNES/PNHS)

Unit Size	009				012			015		
Voltage ⁴	115	208	230	265	208	230	265	208	230	265
Full Load Amps—Cooling Only ^{2,3}	6.4	5.8	5.2	4.5	6.9	6.3	5.8	8.9	8.0	7.4
Cooling Capacity Btuh ¹	9200	9200	9200	9200	11,200	11,200	11,200	13,000	13,000	13,000
Sensible Cooling Capacity, Btuh	6400	6400	6400	6400	7200	7200	7200	8100	8100	8100
Watts	939	939	939	939	1217	1217	1217	1529	1529	1529
EER	9.8	9.8	9.8	9.8	9.2	9.2	9.2	8.5	8.5	8.5
Outside Air Ventilation %	20	20	20	20	20	20	20	20	20	20
Auxiliary Electric Heat Elements (Total Amps)										
2.2 kW	—	—	9.9	8.8	—	9.9	8.8	—	9.9	9.8
2.3 kW	—	11.4	—	—	11.4	—	—	11.4	—	—
2.9 kW	—	—	12.9	11.4	—	12.9	11.4	—	12.9	11.4
3.2 kW	—	15.7	—	—	15.7	—	—	15.7	—	—
3.7 kW	—	—	—	14.4	—	—	14.4	—	—	14.4
3.9 kW	—	—	17.3	—	—	17.3	—	—	17.3	—
4.2 kW	—	20.5	—	—	20.5	—	—	20.5	—	—

1 Based on ASHRAE and AHRI standard test conditions of 95°F (35°C) DB / 75°F (24°C) WB outdoor air and 80°F (27°C) DB / 67°F (16°C) WB indoor air.
 2 Includes fan motor.
 3 Based on high fan speed.
 4 All voltages 60Hz, single phase.

PTAC/PTHP

Water Source Heat Pumps

Water Source Heat Pump Product Summary Chart

Model:

Horizontal

SmartSource™ High Efficiency
Enfinity™

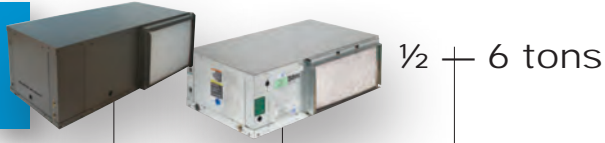

½ — 6 tons

Large Horizontal

Enfinity™



6 — 10 tons

Vertical

SmartSource™ High Efficiency
Enfinity™



¾ — 6 tons

Vertical

SmartSource™ Inverter

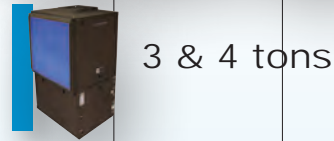

3 & 4 tons

Large Vertical

Enfinity™



6 — 25 tons

Rooftop

Outdoor Curb-Mounted



12 — 35 tons

Vertical Stack

Enfinity™

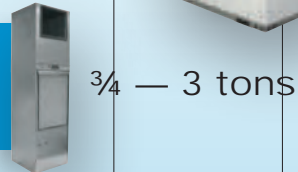

¾ — 3 tons

Console

Enfinity™

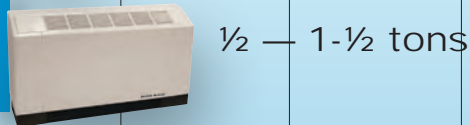

½ — 1-½ tons

Water to Water

Floor-Mounted



3 — 35 tons

Tons

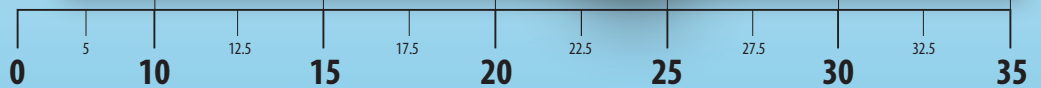

SmartSource™ Water Source Heat Pumps

½ to 6 Ton Single Stage and 2 to 6 Ton 2-Stage High Efficiency

- Industry-leading efficiencies with low-noise operation, high indoor air quality and consistent air temperatures. Excellent for geothermal applications
- Two-stage and inverter units typically operate at low compressor and fan speeds resulting in even quieter operation, very low energy consumption and very uniform room air temperatures
- Ideal for schools, clinics, office buildings, multi-unit living facilities and other projects, both new construction and retrofit, where high efficiency is a key specification
- High EERs make SmartSource units perfect for LEED projects and rebate opportunities

For the most current information, refer to DaikinApplied.com.



Vertical High Efficiency



Horizontal High Efficiency



3 and 4 Ton Vertical Inverter

SmartSource Delivers the Best Efficiencies

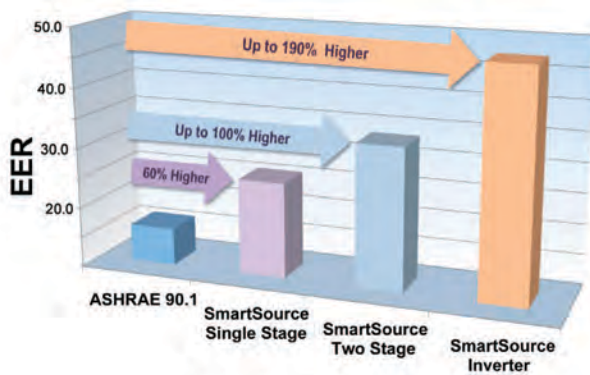

Why Part Load Efficiency Matters Most

(Sample Building Load Profile, St. Louis, MO)

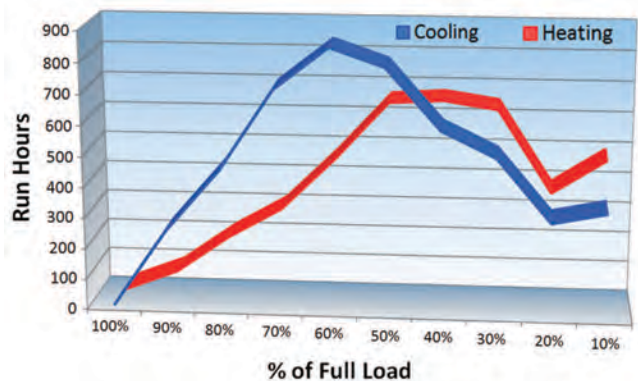

Contact a local Daikin sales representative for the latest information.

SmartSource WSHP Features and Options



- 1 **ECM fan motor:** 4 field adjustable cfm settings and 28 programmed cfm values provide a wide range of airflow selections for quieter operation and lower energy consumption.
- 2 **Single and two-stage compressor:** available in a variety of commercial voltages, mounted on a double isolation system for reduced sound and vibration transmission.
- 3 **Refrigerant circuit:** Utilizes R-410A refrigerant with a bi-flow thermal expansion valve for precise metering and four way solenoid reversing valve.
- 4 **MicroTech III SmartSource controls:** Easy open-protocol integration with optional LonWORKS or BACnet.
- 5 **Unit status LED:** Instant visuals on unit operation for easy troubleshooting and advanced diagnostics.
- 6 **4-Sided filter rack with standard 2" or optional 4" filters:** Designed for easy duct connection and filter maintenance. MERV 8 & 13 filter options with gasketed filter seals to meet LEED-NC EQc5 applications with a leakage rate less than 4 CFM per square foot of filter area at 0.5" ESP.
- 7 **Stainless steel drain plan:** sloped with lipless drain connection for positive condensate flow to meet ASHRAE 62.1 Section 5.11.
- 8 **Flush mounted fittings:** Easy one-wrench connection, securely fastened to the cabinet corner posts.
- 9 **Blower and motor orifice ring:** Easy service without removing the blower housing or disconnecting the unit from the duct work.
- 10 **Durable cabinet construction:** Heavy gauge steel with powder coated textured paint, lined with cleanable, foil-faced insulation on the airside.

NOTE: Features and options are subject to change without notice

Many Factory-Mounted Options and Accessories

Four unique dehumidification options:

1. **Smart dehumidification:** Uses hot gas reheat, humidistat, 2-stage thermostat & smart air flow management for precise humidity control.
2. **Simplified dehumidification:** Uses a 3-stage thermostat to optimize unit capacity and fan speed for maximum latent capacity while decreasing room humidity levels.
3. **Humidistat controlled Dehumidification:** Uses a humidistat and 2-stage thermostat to control room humidity levels.
4. **Dehumidification only:** Uses a humidistat in cooling only mode.

- **Waterside economizer:** Reduces compressor energy consumption by using a cold water coil for cooling under suitable conditions.
- **Loop pumps:** Convenient factory-mounted pumps with flow and head capabilities for most geothermal applications.
- **Desuperheater:** For “free” domestic hot water (Vertical only).
- **5, 10, 15 & 20 kW electric heat:** Electric heat coil with controls for primary, supplemental, boilerless or emergency heat. (Available as field-installed duct heater kit for horizontal units).
- **Non-fused disconnect option:** Convenient Power shut-off and lockout at the unit.
- **Extended range coaxial heat exchanger coil and piping Insulation:** for geothermal application.
- **Insulation options:** Foil faced, closed cell or 1/2" standard fiberglass options for the air and compressor side of the unit.
- **Epoxy coated coils:** For extra corrosion protection to meet ASTM B-11 3000 hour salt spray test.
- **Deluxe sound package:** Reduces sound levels for quieter operation.
- **5-Year extended parts warranty available.**

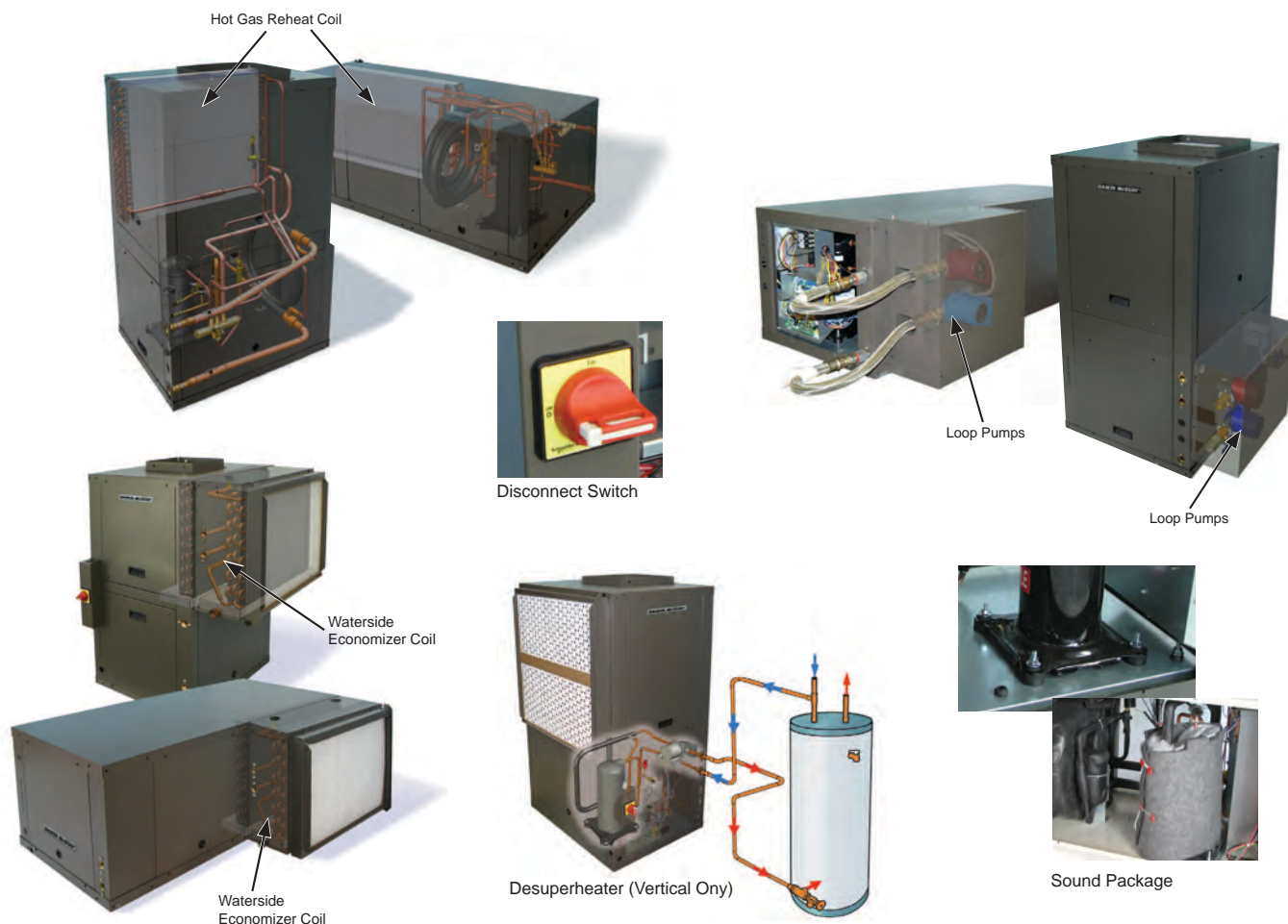

SmartSource Water Source Heat Pumps

Dimensions

Single Stage Unit Size	Model GSV			Model GSH		
	W	D	H	W	L	H
007, 009, 012	21.60 (549)	22.65 (575)	34.50 (876)	21.60" (549)	45.00" (1143)	17.30" (439)
015, 019	22.40 (569)	25.60 (650)	37.50 (953)	22.40" (569)	50.30" (1278)	19.30" (490)
024, 030	22.40" (569)	26.00" (660)	48.00" (1219)	22.40" (569)	63.30" (1608)	19.30" (490)
036	25.00" (635)	32.50" (826)	50.50" (1283)	25.00" (635)	73.00" (1854)	21.30" (541)
042, 048	25.00" (635)	32.50" (826)	54.50" (1384)	25.00" (635)	78.40" (1991)	21.30" (541)
060, 070	25.00" (635)	32.50" (826)	58.50" (1486)	25.00" (635)	83.80" (2129)	21.30" (541)
2-Stage Unit Size	Model GTV			Model GTH		
026, 032	22.40" (569)	26.00" (660)	48.00" (1219)	22.40" (569)	63.30" (1608)	19.30" (490)
038	25.00" (635)	32.50" (826)	50.50" (1283)	25.00" (635)	73.00" (1854)	21.30" (541)
044, 049	25.00" (635)	32.50" (826)	54.50" (1384)	25.00" (635)	78.40" (1991)	21.30" (541)
064, 072	25.00" (635)	32.50" (826)	58.50" (1486)	25.00" (635)	83.80" (2129)	21.30" (541)

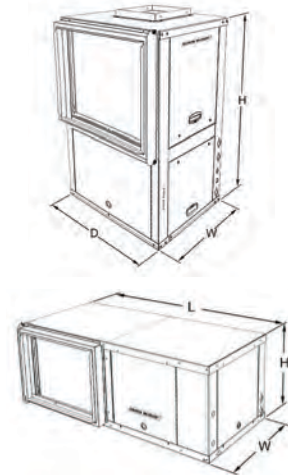

Performance Data – Single Stage Models GSV and GSH

Unit Size	Stage	CFM	GPM	Water Loop (Boiler Tower)				Ground Loop (Geothermal)			
				Cooling		Heating		Cooling		Heating	
				Btu/hr	EER	Btu/hr	COP	Btu/hr	EER	Btu/hr	COP
007	Full Load	250	2.2	8000	16.8	9800	5.5	8400	19.8	6200	3.9
009	Full Load	300	2.4	9700	16.0	12000	5.5	10200	18.8	7500	3.8
012	Full Load	400	3.3	12700	15.5	15700	5.4	13300	18.1	10000	3.9
015	Full Load	500	3.8	15300	18.1	19100	5.9	16000	21.2	11700	4.1
019	Full Load	600	4.4	17500	17.3	22600	5.7	18700	20.6	13800	4.1
024	Full Load	800	6.5	26,200	18.8	28,900	6.0	27,500	22.2	17,700	4.1
030	Full Load	1,000	7.5	30,000	17.3	33,600	5.8	31,300	20.1	21,600	4.1
036	Full Load	1,250	9.0	37,300	19.2	40,800	6.0	38,500	22.0	26,200	4.3
042	Full Load	1,400	10.5	43,900	17.5	48,600	5.4	45,500	20.2	31,300	4.0
048	Full Load	1,600	12.2	50,500	17.2	57,100	5.3	52,700	19.9	36,900	4.0
060	Full Load	2,000	16.0	63,700	17.4	74,200	5.2	66,300	20.0	46,500	3.8
070	Full Load	2,160	17.5	73,400	15.9	89,000	5.0	75,700	18.0	55,800	3.7

Performance Data – 2-Stage Models GTV and GTH

Unit Size	Stage	CFM	GPM	Water Loop (Boiler Tower)				Ground Loop (Geothermal)			
				Cooling		Heating		Cooling		Heating	
				Btu/hr	EER	Btu/hr	COP	Btu/hr	EER	Btu/hr	COP
026	Part Load	700	6.5	19,800	20.2	21,800	6.4	22,200	29.7	15,100	4.5
	Full Load	800	6.5	26,400	18.0	29,300	5.7	27,600	20.7	18,100	4.1
032	Part Load	875	7.5	24,700	18.5	27,800	6.0	33,800	25.9	19,800	4.5
	Full Load	1,000	7.5	32,500	16.5	36,400	5.3	33,800	18.9	23,700	4.1
038	Part Load	1,100	9.0	28,300	20.2	32,600	6.4	30,500	28.8	22,500	4.6
	Full Load	1,250	9.0	39,000	17.6	44,400	5.6	40,200	20.1	28,100	4.2
044	Part Load	1,225	10.5	32,900	19.7	36,600	6.0	35,500	28.3	25,600	4.3
	Full Load	1,400	10.5	44,400	17.3	50,100	5.4	45,900	19.8	31,700	4.0
049	Part Load	1,400	12.2	36,900	19.5	40,800	6.0	39,600	28.2	29,200	4.4
	Full Load	1,600	12.2	48,900	16.7	55,300	5.3	50,600	19.2	35,900	4.0
064	Part Load	1,750	16.0	48,200	19.6	53,800	5.8	52,200	27.9	38,300	4.3
	Full Load	2,000	16.0	64,800	17.4	76,100	5.2	67,100	19.7	47,000	3.9
072	Part Load	1,920	17.5	56,400	18.4	64,600	5.4	60,700	26.1	46,200	4.1
	Full Load	2,160	17.5	72,700	15.9	88,400	5.0	75,300	18.1	55,200	3.7

SmartSource Inverter WSHP Features and Options



- 1 **Variable speed ECM fan motor:** Easy control of airflow for quiet operation and improved comfort.
- 2 **Variable speed inverter compressors:** Delivers enhanced comfort and saves energy.
- 3 **Remote controller:** Large display with easy access to room temperature control and unit diagnostics.
- 4 **LED status board:** Easy troubleshooting with instant visuals and advanced diagnostics on unit operation.
- 5 **Low voltage terminal block (X2M):** Make quick field connections with easy access to the low voltage terminal block, saving installation time.
- 6 **2" filter rack with standard 1" or optional 2" filter:** Improved IEQ to meet LEED EQc5 with optional 2" MERV 13 filter. Also available with an optional 2" MERV 8 filter or the standard 1" low static filter. Convenient duct connection is combined with tool-less filter access door, makes filter replacement a snap.
- 7 **Drain pan:** Positive condensate flow to meet ASHRAE 62.1 Section 5.11 with the double-sloped condensate pan with lipless drain connection.
- 8 **Flush mounted fittings:** Save installation time with easy one-wrench flush mounted pipe connections, securely fastened to the cabinet corner posts.
- 9 **Blower and motor orifice ring:** Easy service without removing the blower housing or disconnecting the unit from the duct work.
- 10 **Durable cabinet construction:** Attractive and durable powder coated textured paint is lined with dual-density fiberglass insulation on the airside for lower discharge air sound.

Expanded Capabilities and...

Added Value Options:

- Desuperheater, for “free” domestic hot water
- Emergency back-up electric heat.
- Field-installed loop pump packages
- Filters, MERV 8 and MERV 13 to meet LEED EQ Credit 5.
- Non-fused disconnect switch located on the unit front corner post, to break power to the unit for ease of field service

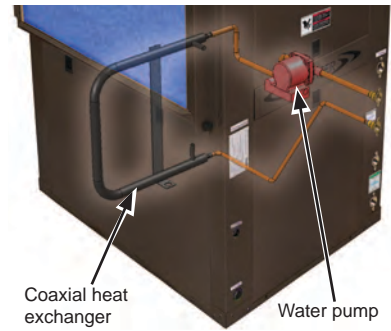

Desupeheater

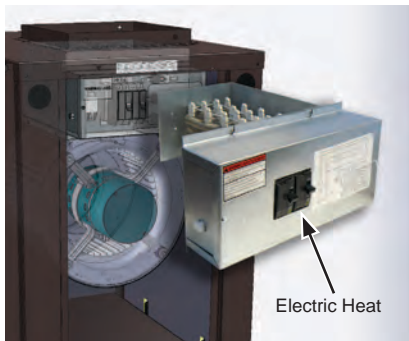

Emergency Back Up Heat

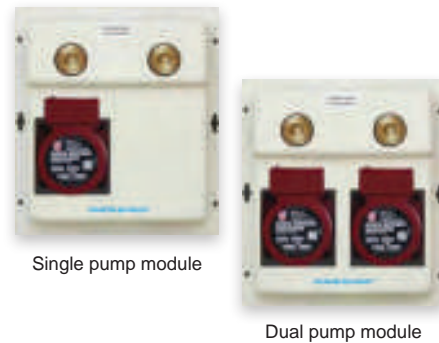

Loop Pump Packages

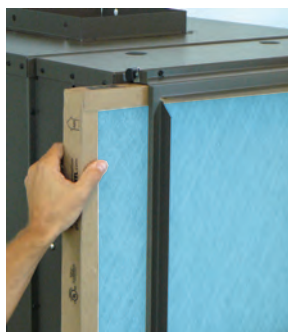

Variety of Filter Options



Non-Fused Disconnect Switch

Disconnect Switch

...Built-In Comfort Advantages

Advanced Comfort Features:

- Built in dehumidification through “dry” mode operation
- User friendly controls with 7-day programming, automatic changeover, operation history and service data access
- LED Status Board, easy troubleshooting with instant visuals and advanced diagnostics on unit operation
- Extended compressor reliability with fewer start/stop cycles, voltage peaks, and very low compressor sound levels



User Friendly Controls

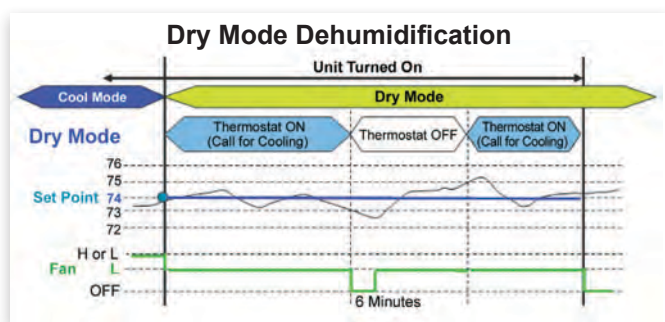

LED Status Board



Compressors

Pushing Energy Efficiency Past 60 EER

The Daikin compressor modulates to match the load requirements, delivering only the required energy to satisfy the space conditions. Efficiency increases as the system unloads, driving the energy efficiency up while maintaining comfort in the space by keeping the temperature closer to set point. Since most of the operating hours are under part load conditions, the SmartSource Inverter can take advantage of low airflows while operating quietly at reduced energy levels.

Heating efficiency approaching 7.0

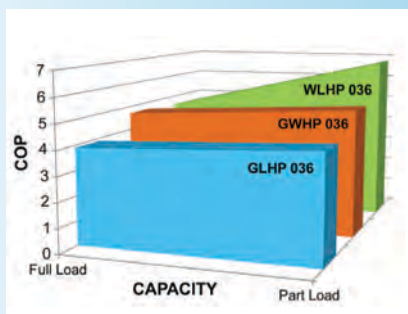

Cooling efficiency extended past 60 EER

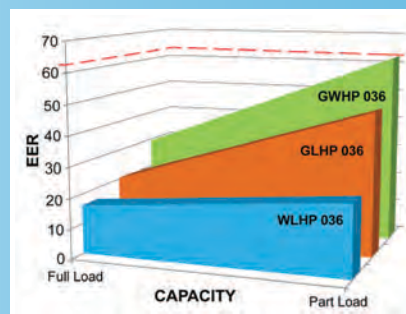

SmartSource Inverter Water Source Heat Pumps

Dimensions – Models WDFW

Unit Size	W	D	H
036	25.00" (635)	32.50" (826)	50.50" (1283)
048	25.00" (635)	32.50" (826)	58.50" (1486)

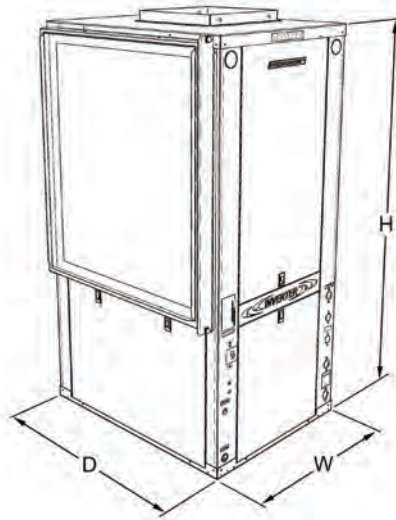

AHRI Performance Data Rated in accordance with AHRI/ASHRAE/ISO Standard 13256-1.

Unit Size	Capacity Modulation	GPM	Cooling			Heating		
			CFM	Total Cap	EER	CFM	Total Cap	COP
Water Loop^{1, 2}								
036	Full load	9.0	1160	31,900	16.2	1160	32,100	4.6
	Part load	9.0	1160	14,400	23.8	1160	10,900	6.8
048	Full load	12.0	1600	42,300	15.9	1600	47,900	5.3
	Part load	12.0	1600	21,600	20.1	1600	21,200	7.1
Ground Water^{1, 2}								
036	Full load	9.0	1160	38,900	29.4	1160	30,100	4.7
	Part load	9.0	1160	15,900	62.5	1160	9,900	5.2
048	Full load	12.0	1600	50,900	30.5	1600	40,700	4.7
	Part load	12.0	1600	17,200	39.2	1600	18,800	5.1
Ground Loop^{1,2}								
036	Full load	9.0	1160	35,600	20.4	1160	23,400	3.9
	Part load	9.0	1160	15,600	47.3	1160	8,700	4.3
048	Full load	12.0	1600	46,600	20.2	1600	32,000	3.9
	Part load	12.0	1600	21,700	33.4	1600	17,100	4.5

Legend: CFM = Airflow Rate, Cubic Feet per Minute Total Cap., Btu/h = Total Capacity British Thermal Units per Hour, COP = Coefficient of Performance
 EER = Energy Efficiency Ratio, GPM = Gallons per Minute, EAT = Entering Air Temperature, EWT = Entering Water Temperature

Water Loop:
 1. Cooling capacity based on 80.6°F db, 66.2°F wb (27/19°C) EAT and 86°F (30°C) EWT.
 2. Heating capacity is based on 68°F (20°C) EAT and 68°F (20°C) EWT.

Ground Water:
 1. Cooling capacity is based on 80.6°F db, 66.2°F wb (27/19°C) EAT and 59°F (15°C) EWT.
 2. Heating capacity is based on 68°F (20°C) EAT and 50°F (10°C) EWT.

Ground Loop:
 1. Cooling capacity is based on 80.6°F db, 66.2°F wb (27/19°C) EAT and 77°F (25°C) EWT at full load or 68°F (20°C) at part load.
 2. Heating capacity is based on 68°F (20°C) EAT, and 32°F (0°C) EWT at full load or 41°F (5°C) at part load.

Small Horizontal Ceiling-Mounted—1/2 to 6 Tons

- Non-CFC, R-410A refrigerant
- Standard or geothermal application flexibility
- Easy, low cost design and installation
- High efficiency reduces energy consumption/operating costs and can contribute to earning LEED® points and rebates
- Superior indoor air quality and quiet operation
- Easy, low cost maintenance and service
- MicroTech® III unit controls with Open Choices™ feature allows standalone or network operation using LONWORKS® or BACnet® communication options
- Performance rated with ISO Standard 13256-1

For more detail, refer to Catalog 1108.

For the most current information, refer to DaikinApplied.com.



Enfinity™ R-410A Models

WCCH - Standard Range: 55° to 110° F
 WCCW - Geothermal Range: 30° to 110° F



R-410A refrigerant with no ozone depletion potential

Water Source Heat Pump Systems

Boiler/tower



A “Boiler/Tower” application uses a simple two-pipe water circulating system that adds heat, removes heat or transfers rejected heat to other units throughout the building. The water temperature for heating is usually provided by a natural gas or electric boiler located in a mechanical room. The condensing water temperature is provided by a cooling tower that dissipates waste heat. This application can be the lowest cost of the loop options available.

Open loop “well water”



“Open Loop” well water systems use ground water to remove or add heat to the interior water loop. The key benefit of an open loop system is the constant water temperature, usually 50°F to 60°F, which provides efficient operation at a low first cost. Open Loop applications are commonly used in coastal areas where soil characteristics allow reinjection wells to return the water back to the aquifer. Reinjection wells must be approved by the U.S. Environmental Protection Agency.

Geothermal closed loop



Vertical Loops (shown) are installed by drilling vertical bore holes into the earth and inserting a plastic polyethylene supply/return pipe into the holes. Horizontal loops are installed in trenches approximately 5 feet below the ground surface. Both vertical and horizontal loops extract the Earth’s natural heat and reject it back.

Surface water or lake loop



A “Surface Water” or “Lake” closed loop system is a geothermal loop that is directly installed in a lake or body of water that is near the building. In many cases, the body of water is constructed on the building site to meet drainage or aesthetic requirements. The size and the depth of the lake is critical and commercial design services should be used that certify a given body of water is sufficient to withstand the building loads.



WCCH and WCCW Features and Options

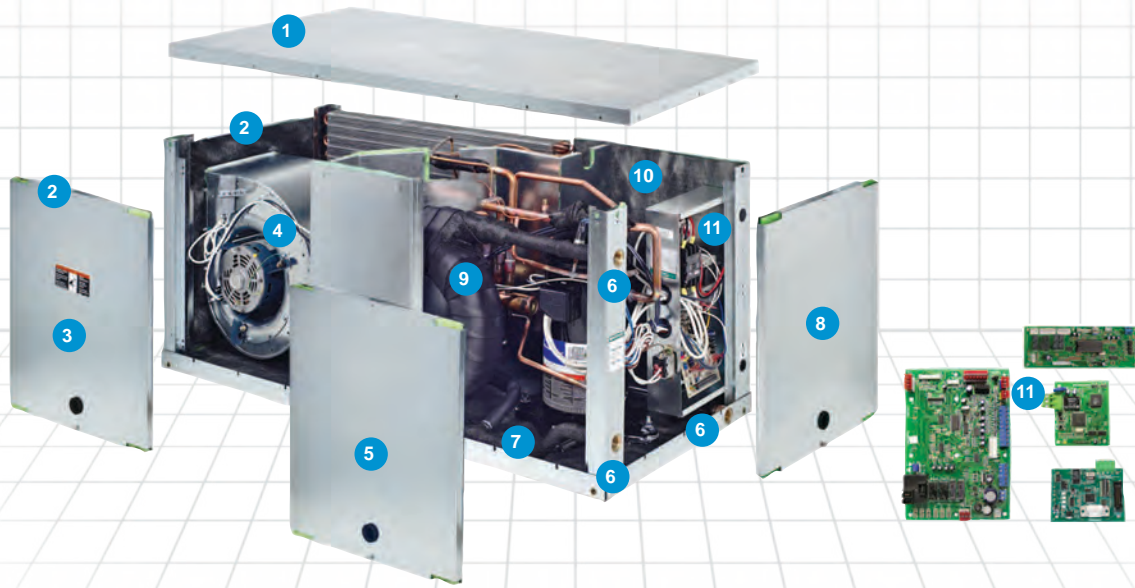

- 1 Durable, heavy gauge steel cabinet construction
- 2 Field interchangeable panels for side or end discharge air arrangement
- 3 Access panel for blower and motor
- 4 Large blower and PSC motor or optional high-efficiency ECM size 1¾ to 6 ton
- 5 Access panel for compressor section and refrigerant service valves
- 6 Flush mounted water and drain connections
- 7 Vibration isolated rotary, reciprocating or scroll compressor
- 8 Access panel for compressor section and control box
- 9 High efficiency coaxial heat exchanger (insulated for geothermal models)
- 10 Dual-density fiberglass panels (closed cell insulation optional)
- 11 MicroTech® III standalone or network controls using LONWORKS® or BACnet® communication options
 - MicroTech III Unit Controller
 - I/O expansion module
 - LONWORKS & BACnet communication modules
- 12 Two CoreMax refrigerant service valves by FastTest® (high and low side—not visible)

Four Different Air Configurations

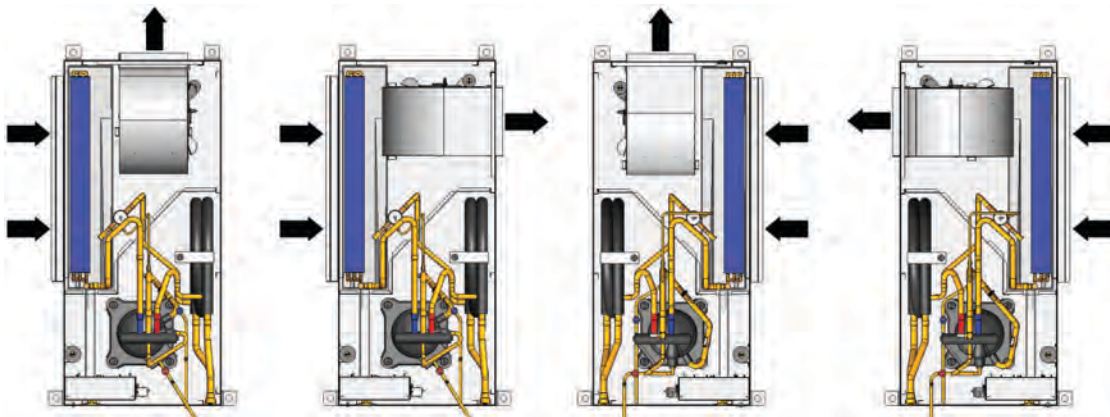

Left-hand return with end discharge

Left-hand return with straight discharge

Right-hand return with end discharge

Right-hand return with straight discharge

Water Source Heat Pumps



Plastic, double-sloped drain pan to prevent standing water

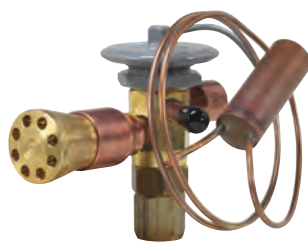

Thermal expansion valve on all standard and geothermal models



Removable orifice ring for ease of service

2-stage unit available as a special. Please contact your Daikin representative for details.

Performance Data

Enfinity R-410A Models WCCH/WCCW with PSC Fan Motor

Unit size	Airflow		Water flow		Water loop ¹						Ground loop ²						Dimensions L x W x H (inches)		
					Cooling 86°F (30°C)			Heating 68°F (20°C)			Cooling 77°F (25°C)			Heating 32°F (0°C)					
	cfm	L/S	GPM	L/S	Btu/hr	Watts	EER	COP	Btu/hr	Watts	COP	Btu/hr	Watts	EER	COP	Btu/hr		Watts	COP
007	300	142	2.1	0.14	8000	2346	11.8	3.5	10,700	3137	4.2	8900	2610	14.4	4.2	7100	2082	3.1	34 x 20 x 11.5
009	300	142	2.3	0.14	8800	2581	12.9	3.8	11,800	3460	4.6	9200	2698	14.8	4.3	7400	2170	3.3	34 x 20 x 11.5
012	400	189	3.0	0.19	12,900	3783	12.7	3.7	15,800	4633	4.3	13,900	4076	15.0	4.4	10,400	3050	3.1	40 x 20 x 11.5
015	630	297	3.8	0.24	15,700	4598	16.0	4.7	18,100	5301	5.2	16,900	4950	18.7	5.5	11,500	3368	3.7	42 x 20 x 19
019	630	297	5.3	0.33	21,000	6149	14.9	4.7	23,600	6920	4.8	22,600	6628	17.3	5.1	14,700	4311	3.6	42 x 20 x 19
024	800	378	6.2	0.39	24,700	7232	14.4	4.4	28,400	8328	4.7	26,300	7713	16.6	4.9	18,000	5279	3.6	42 x 20 x 19
030	1000	472	7.6	0.48	30,400	8915	15.3	4.2	36,200	10,616	5.0	31,500	9238	17.7	5.1	23,100	6774	3.6	46 x 21 x 20
036	1200	566	9.0	0.57	35,800	10,499	15.2	4.5	42,500	12,463	4.9	37,800	11,085	17.7	4.7	28,400	8328	3.6	46 x 21 x 20
042	1400	661	10.7	0.68	43,000	12,610	15.0	4.5	50,700	14,868	5.0	44,500	13,050	17.1	5.0	33,900	9941	3.7	52 x 28 x 23
048	1600	755	12.3	0.78	48,400	14,194	14.1	4.4	57,100	16,745	4.7	50,200	14,721	16.1	4.7	38,400	11,261	3.7	52 x 28 x 23
060	2000	944	15.2	0.96	59,500	17,449	14.6	4.1	69,400	20,352	4.9	61,500	18,035	16.8	4.7	47,500	13,930	3.7	52 x 28 x 23

1. Rated in accordance with ISO Standard 13256-1 Boiler/Tower.
2. Rated in accordance with ISO Standard 13256-1 Ground Loop.

Enfinity R-410A Models WCCH/WCCW with ECM Fan Motor

Unit size	Airflow		Water flow		Water loop ¹						Ground loop ²						Dimensions L x W x H (inches)		
					Cooling 86°F (30°C)			Heating 68°F (20°C)			Cooling 77°F (25°C)			Heating 32°F (0°C)					
	cfm	L/S	GPM	L/S	Btu/hr	Watts	EER	COP	Btu/hr	Watts	COP	Btu/hr	Watts	EER	COP	Btu/hr		Watts	COP
015	500	297	3.8	0.24	16,000	4686	17.6	5.1	18,100	5301	5.6	17,200	5037	20.8	6.1	11,500	3368	4.0	42 x 20 x 19
019	630	297	5.3	0.33	20,900	6129	15.7	4.6	23,700	6950	5.1	22,600	6628	18.4	5.4	14,800	4340	3.8	42 x 20 x 19
024	800	378	6.2	0.39	24,700	7243	14.7	4.3	28,500	8358	4.9	26,300	7713	17.0	5.0	18,100	5308	3.7	42 x 20 x 19
030	1000	472	7.6	0.48	30,500	8944	15.9	4.7	36,100	10,587	5.3	31,600	9267	18.4	5.4	23,000	6745	3.8	46 x 21 x 20
036	1200	566	9.0	0.57	36,000	10,559	16.0	4.7	42,400	12,434	5.2	38,000	11,144	18.8	5.6	28,700	8416	3.8	46 x 21 x 20
042	1400	661	10.7	0.68	43,000	12,610	15.5	4.6	51,600	15,132	5.2	44,100	12,933	17.9	5.3	34,600	10,147	3.8	52 x 28 x 23
048	1600	755	12.3	0.78	48,700	14,282	15.6	4.6	57,700	16,921	5.2	50,600	14,839	18.2	5.4	39,300	11,525	3.9	52 x 28 x 23
060	2000	944	15.2	0.96	59,700	17,507	15.5	4.6	69,300	20,323	5.2	61,700	18,094	17.9	5.3	48,000	14,076	3.9	52 x 28 x 23
070	2330	944	18.0	1.14	71,300	20,880	12.7	3.7	88,100	25,800	4.2	73,800	21,610	14.3	4.2	59,300	17,370	3.3	52 x 28 x 23

1. Rated in accordance with ISO Standard 13256-1 Boiler/Tower.
2. Rated in accordance with ISO Standard 13256-1 Ground Loop.

Large Horizontal Ceiling-Mounted—6 to 10 Tons

- High efficiency and quiet operation
- Standard or geothermal application flexibility
- Large panels for accessibility to compressor and fan sections
- Flexible fan discharge options
- Belt-driven blower motor
- MicroTech® III unit controls with Open Choices™ feature allows standalone or network operation using LONWORKS® or BACnet® communication options
- Performance rated with ISO Standard 13256-1
- R-410A refrigerant

For more detail, refer to Catalog 1112.

For the most current information, refer to DaikinApplied.com.



**Enfinity™
Models WCCH/WCCW**



Performance Data—Large Horizontal Ceiling-Mounted

Unit size	Air flow cfm (L/S)	Water flow gpm (L/S)	Voltage	Water loop				Ground loop				Dimensions L x W x H, in (mm)
				Cooling ²		Heating ³		Cooling ⁴		Heating ⁵		
				Btu/hr (Watts)	EER ¹	Btu/hr (Watts)	COP ¹	Btu/hr (Watts)	EER ¹	Btu/hr (Watts)	COP ¹	
072	2400 (1133)	20.1 (1.27)	208-60-3	78,100 (22,868)	13.4	82,700 (24,215)	4.4	77,700 (22,751)	16.3	58,700 (17,188)	3.7	78 x 44 x 29 (1981 x 1118 x 737)
			230-60-3									
			460-60-3									
			575-60-3									
096	3000 (1416)	223.6 (1.49)	208-60-3	94,900 (27,788)	14.8	94,300 (27,612)	4.3	97,300 (28,490)	16.8	66,100 (19,355)	3.3	
			230-60-3									
			460-60-3									
			575-60-3									
120	4000 (1888)	30.1 (1.9)	208-60-3	12,1000 (35,664)	12.6	135,000 (41,052)	4.3	125,000 (36,221)	14.1	81,500 (24,479)	3.2	
			230-60-3									
			460-60-3									
			575-60-3									

1. EER = Energy Efficiency Ratio COP = Coefficient of Performance.

2. Water Loop cooling capacity is based on 80.6°F db, 66.2°F wb entering air temperature and 86°F entering water temperature.

3. Water Loop heating capacity is based on 68°F entering air temperature and 68°F entering water temperature.

4. Ground Loop cooling capacity is based on 80.6°F db, 66.2°F wb entering air temperature and 77°F entering water temperature.

5. Ground Loop heating capacity is based on 68°F entering air temperature and 32°F entering water temperature.

Vertical Floor-Mounted—3/4 to 6 Tons

- Standard or geothermal application flexibility
- R-410A refrigerant with no ozone depletion potential or phase-out date
- High efficiency reduces energy consumption/operating costs and can contribute to earning LEED® points and rebates
- Superior indoor air quality and quiet operation
- MicroTech® III unit controls with Open Choices™ feature allows standalone or easy, low cost network integration using LonWorks® or BACnet® communication options
- Multiple factory-installed features/options - including desuperheater, hot gas reheat, auxiliary electric heat, ECM fan motor, two-way motorized valve and compressor sound blanket, allow you to closely match application requirements and lower installation costs
- Performance rated with ISO Standard 13256-1

For more detail, refer to Catalog 1103.

For the most current information, refer to DaikinApplied.com.



Plastic, double-sloped drain pan to prevent standing water

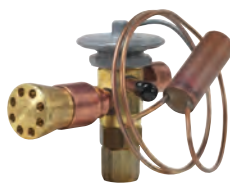

Thermal expansion valve on all standard and geothermal models



Removable orifice ring for ease of service

Flexible Air Configurations (Top View)

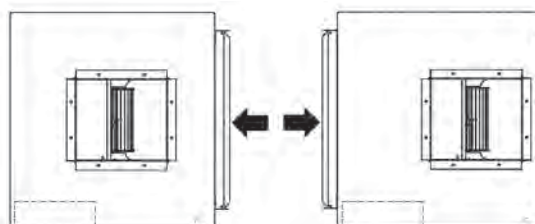

Right hand return top discharge

Left hand return top discharge



WVFC and WVFW Features and Options

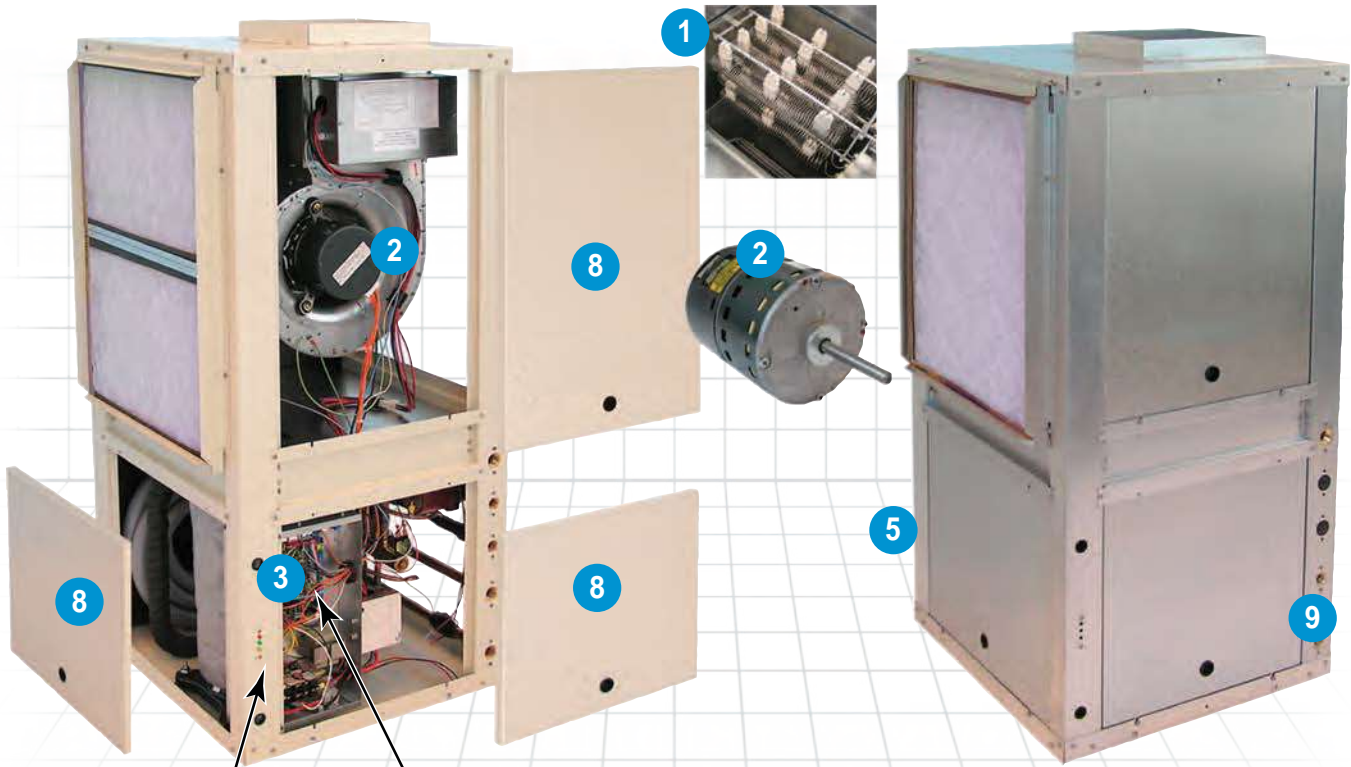

MicroTech[®] III Unit Controller



I/O Expansion Module



LonWorks[®] & BACnet[®] Communication Modules



2" Filter Racks (optional) for High Efficiency Filters and Easy Tool-less Removal (optional)



Desuperheater - Heat Exchanger and Water Pump Piping Circuit (optional)

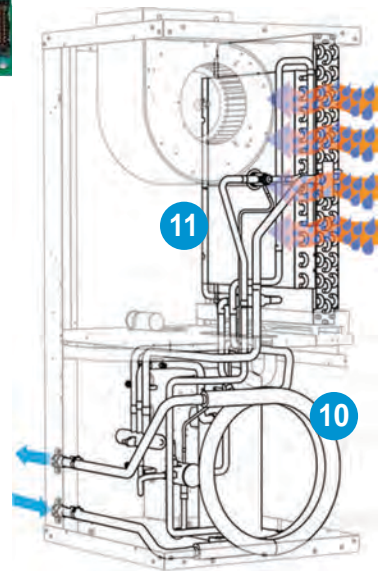

Hot Gas Reheat Coil & Piping Circuit (optional)

WVFC and WFW Features and Options

1 Electric heat (optional)

- Integral electric heat coil provides supplemental or emergency heat when conditions require

2 Electronically commutated motor (ECM) optional

- ECM motor provides quiet, efficient operation while maintaining constant CFM over its static operating range. Unit can be wired for optional 2 or 5 speed fan operation

3 MicroTech® III unit controller

- Open Choices™ feature allows standalone or easy, low cost network integration using LonWORKS® or BACnet® communication options

4 LED annunciator

- External LED status lights display fault conditions to provide easy troubleshooting and diagnosis

5 Compact cabinet

- The standard unit is constructed of unpainted G-60 galvanized steel, with the smallest possible footprint. Optional painted cabinet is ideal for aesthetic requirements of residential applications

6 Desuperheater (optional)

- Saves energy by heating domestic hot water using a small heat exchanger and water pump located in the compressor compartment. Superheated refrigerant gas from the compressor is used to heat water. This reduces the amount of additional energy required to heat water and it may eliminate the requirement for separate water heating equipment

7 Filter & filter rack

- Units come standard with a 1" (25.4 mm) thick throwaway filter mounted in a 4-sided combination filter rack and return air duct collar. This eliminates the added labor and cost to field-mount brackets. Filters can be easily removed from any side. A 2" filter rack is available as a factory-installed selectable option to accept higher efficiency filters, or a 2 inch field installed kit

8 Removable access panels

- Two front panels provide easy access to the blower motor and unit controls. Two rear panels provide easy access to the fan housing and compressor section

9 Piping connections

- Water connections are FPT water fittings, flush with the outside of the cabinet for easy one-wrench connection to units
- A large condensate connection provides proper condensate removal

10 Coaxial heat exchanger

- Designed for maximum heat transfer at normal and low water flow rates with minimum pressure drop. The inside tube is deeply fluted to enhance heat transfer and minimize fouling. A cupronickel heat exchanger is available as a selectable option

11 Hot gas reheat coil (optional)

- Uses expelled heat from the refrigeration cycle and redirects it through an isolated circuit in the evaporator section. For every 10°F of temperature rise across the hot gas reheat coil there is approximately a 20% drop in the discharge air relative humidity (%Rh). The hot gas reheat coil prevents over-cooling of the space when the unit is in dehumidification mode. A wall-mounted humidistat must be used in conjunction with the unit to measure and adjust the humidity setpoint in the space

2-Way motorized isolation valve (optional - not shown)

- Control valve can be factory-installed or field-installed to handle variable speed pumping requirements. Both standard and high cut-off pressure valves are available as a selectable option

Water Source Heat Pumps

Performance Data

Enfinity Vertical Floor-Mounted Models WVFC and WVFW—Water Loop

Unit size	Airflow		Water flow		Water loop - standard unit							Water loop - ECM @ high static							Dimensions L x W x H (inches)
					Cooling ² 86°F (30°C)				Heating ³ 68°F (20°C)			Cooling ² 86°F (30°C)				Heating ³ 68°F (20°C)			
	cfm	L/S	GPM	L/S	Btu/hr	Watts	EER ¹	COP ¹	Btu/hr	Watts	COP ¹	Btu/hr	Watts	EER ¹	COP ¹	Btu/hr	Watts	COP ¹	
009	300	142	2.3	0.15	9060	2650	14.0	4.1	10,600	3110	4.7	N/A	N/A	N/A	N/A	N/A	N/A	N/A	22.25 x 20 x 37
012	400	189	3.0	0.19	12,000	3510	14.4	4.2	14,000	4110	4.8	N/A	N/A	N/A	N/A	N/A	N/A	N/A	22.25 x 20 x 37
015	500	236	3.6	0.23	14,700	4300	16.0	4.7	16,100	4720	5.1	N/A	N/A	N/A	N/A	N/A	N/A	N/A	24.25 x 23 x 46.5
019	600	283	4.7	0.30	19,200	5620	15.2	4.5	18,300	5370	4.4	19,500	5710	16.6	4.9	18,000	5270	4.6	24.25 x 23 x 46.5
024	800	378	5.8	0.37	23,800	6980	15.1	4.4	26,700	7820	4.9	24,100	7050	16.3	4.8	26,300	7700	5.2	24.25 x 23 x 46.5
030	1000	472	7.3	0.46	30,000	8800	17.0	5.0	33,400	9780	5.2	29,900	8750	17.0	5.0	33,400	9780	5.4	24.25 x 23 x 50.5
036	1300	614	9.5	0.60	39,500	11,500	14.8	4.3	45,000	13,200	4.6	39,900	11,700	15.0	4.4	44,500	13,000	4.6	24.25 x 23 x 50.5
042	1400	661	11.0	0.69	43,900	12,800	15.0	4.4	52,500	15,400	4.8	44,200	12,900	16.2	4.7	52,300	15,300	5.1	32.5 x 25 x 46.5
048	1600	755	12.0	0.76	48,100	14,100	14.7	4.3	56,800	16,600	4.8	48,700	14,200	16.0	4.7	56,400	16,600	5.1	32.5 x 25 x 46.5
060	2000	944	15.5	0.98	63,200	18,500	15.1	4.4	68,300	20,000	4.7	63,600	18,600	15.7	4.6	67,700	19,800	5.0	32.5 x 25 x 58.5
070	2160	1019	19.0	1.20	75,400	22,100	13.5	4.0	87,300	25,500	4.4	76,200	22,300	14.0	4.1	86,300	25,300	4.5	32.5 x 25 x 58.5

1. EER = Energy Efficiency Ratio COP = Coefficient of Performance.
 2. Cooling capacity is based on 80.6°F db, 66.2°F wb, (27/19°C) entering air temperature and 86°F (30°C) entering water temperature.
 3. Heating capacity is based on 68°F (20°C) entering air temperature and 68°F (20°C) entering water temperature.
- N/A = Option not available.

Enfinity Vertical Floor-Mounted Models WVFC and WVFW—Ground Loop

Unit size	Airflow		Water flow		Ground loop - standard unit							Ground loop - ECM @ high static							Dimensions L x W x H (inches)
					Cooling ² 77°F (25°C)				Heating ³ 32°F (0°C)			Cooling ² 77°F (25°C)				Heating ³ 32°F (0°C)			
	cfm	L/S	GPM	L/S	Btu/hr	Watts	EER ¹	COP ¹	Btu/hr	Watts	COP ¹	Btu/hr	Watts	EER ¹	COP ¹	Btu/hr	Watts	COP ¹	
009	300	142	2.3	0.15	9720	2850	16.7	4.9	7020	2050	3.3	N/A	N/A	N/A	N/A	N/A	N/A	N/A	22.25 x 20 x 37
012	400	189	3.0	0.19	12,700	3720	16.9	5.0	9300	2720	3.5	N/A	N/A	N/A	N/A	N/A	N/A	N/A	22.25 x 20 x 37
015	500	236	3.6	0.23	15,700	4600	19.6	5.7	10,000	2920	3.5	N/A	N/A	N/A	N/A	N/A	N/A	N/A	24.25 x 23 x 46.5
019	600	283	4.7	0.30	19,400	5690	17.3	5.1	13,700	4010	3.5	19,700	5770	19.0	5.6	13,400	3920	3.7	24.25 x 23 x 46.5
024	800	378	5.8	0.37	24,800	7260	14.9	5.2	17,800	5210	3.1	25,100	7350	19.2	5.6	17,500	5120	3.8	24.25 x 23 x 46.5
030	1000	472	7.3	0.46	30,700	9000	19.1	5.6	22,300	6530	3.9	30,600	8960	19.3	5.7	22,300	6530	4.0	24.25 x 23 x 50.5
036	1300	614	9.5	0.60	40,300	11,800	17.3	5.1	30,300	8900	3.4	40,500	11,800	16.6	4.9	30,000	8790	3.3	24.25 x 23 x 50.5
042	1400	661	11.0	0.69	45,400	13,300	17.0	5.0	35,100	10,300	3.6	46,100	13,500	18.9	5.5	34,400	10,100	3.8	32.5 x 25 x 46.5
048	1600	755	12.0	0.76	51,600	15,100	15.8	4.6	40,300	11,800	3.4	50,200	14,700	18.2	5.3	37,600	11,000	3.8	32.5 x 25 x 46.5
060	2000	944	15.5	0.98	65,100	19,100	16.3	4.8	47,000	13,700	3.5	66,000	19,300	18.0	5.3	46,000	13,500	3.8	32.5 x 25 x 58.5
070	2160	1019	19.0	1.20	76,500	22,400	13.7	4.0	58,900	17,200	3.1	78,400	22,900	16.2	4.7	56,800	16,600	3.6	32.5 x 25 x 58.5

1. EER = Energy Efficiency Ratio COP = Coefficient of Performance.
 2. Cooling capacity is based on 80.6°F db, 66.2°F wb, (27/19°C) entering air temperature and 77°F (25°C) entering water temperature.
 3. Heating capacity is based on 68°F (20°C) entering air temperature and 32°F (0°C) entering water temperature.
- N/A = Option not available.

Water Source Heat Pumps

Infinity Vertical ISO Performance Data—Ground Source

Ground Source Performance Data Rated in Accordance with ISO Standard 13256-1

Unit size	Airflow		Water flow		Voltage	Standard Unit						ECM at High Static							
	cfm	L/S	GPM	L/S		Cooling				Heating		Cooling				Heating			
						Btu/h	Watts	EER	COP	Btu/h	Watts	COP	Btu/h	Watts	EER	COP	Btu/h	Watts	COP
009	300	142	2.3	0.15	115-1-60 208/230-1-60 265-1-60 230-1-50	10900	3200	23.8	7.0	8820	2580	4.0	N/A	N/A	N/A	N/A	N/A	N/A	N/A
012	400	189	3.0	0.19	115-1-60 208/230-1-60 265-1-60	14100	4130	23.8	7.0	11800	3450	4.2	N/A	N/A	N/A	N/A	N/A	N/A	N/A
015	500	236	3.6	0.23	230-1-50 208/230-1-60 265-1-60	17100	5010	28.1	8.2	13100	3830	4.3	N/A	N/A	N/A	N/A	N/A	N/A	N/A
019	600	283	4.68	0.30	230-1-50 208/230-1-60 265-1-60	21400	6270	23.5	6.9	16900	4950	4.1	21600	6320	26.1	7.7	16600	4860	4.4
024	800	378	5.80	0.37	230-1-50 208/230-1-60 265-1-60	26600	7790	23.3	6.8	21700	6360	4.2	26900	7880	25.8	7.6	21300	6240	4.5
030	1000	472	7.25	0.46	230-1-50 208/230-1-60 265-1-60 208/230-3-60	33000	9600	25.1	7.4	28400	8320	4.6	32900	9630	25.5	7.5	28400	8300	4.8
036	1300	614	9.50	0.60	230-1-50 208/230-1-60 208/230-3-60 460-3-60	42900	12500	22.3	6.5	37700	11000	4.1	43000	12600	21.3	6.2	37400	10900	4.0
042	1400	661	11.00	0.69	380-3-50 208/230-3-60 460-3-60 575-3-60	48800	14300	22.1	6.5	42900	12500	4.2	49100	14400	24.8	7.3	43000	12600	4.5
048	1600	755	12.00	0.76	380-3-50 208/230-1-60 208/230-3-60 265-1-60 460-3-60 575-3-60 230-1-50	56100	16400	20.3	5.9	48900	14300	4.0	54300	15900	23.8	7.0	47100	13800	4.5
060	2000	944	15.50	0.98	380-3-50 208/230-1-60 208/230-3-60 265-1-60 460-3-60 575-3-60 230-1-50	69000	20200	20.5	6.0	58400	17100	4.1	69900	20500	22.9	6.7	57400	16800	4.4
070	2160	1019	19.00	1.20	380-3-50 208/230-3-60 460-3-60 575-3-60 380-3-50	79100	23100	16.6	4.9	72700	21300	3.6	80600	23600	19.6	5.7	70500	20600	4.1

N/A = ECM not available in unit sizes 009 or 012.

Heating capacity is based on 68°F (20°C) entering air temperature and 50°F (10°C) entering water temperature.

Table notes:

CFM = Cubic Feet per Minute; L/S = Liters per second; GPM = Gallons Per Minute; Btu/h = BTU per hour; EER = Energy Efficiency Ratio; COP = Coefficient of Performance

Large Vertical Floor-Mounted—6 to 25 Tons

- Standard or geothermal application flexibility
- High efficiency and quiet operation
- Dual compressors on all unit sizes
- Belt driven multiple fans
- Two or 3-fan units and multiple discharge air arrangements
- Multiple access panels
- MicroTech® III unit controls with Open Choices™ feature allows standalone or network operation using LONWORKS® or BACnet® communication options
- Performance rated with ISO Standard 13256-1
- R-410A refrigerant

For more detail, refer to Catalog 1109.

For the most current information, refer to DaikinApplied.com.

Enfinity™ (6 to 25 tons)
WLVC - Standard range: 50°F to 110°F
WLWV - Geothermal range: 30°F to 110°F



Performance Data—Enfinity Large Vertical Floor-mounted

Unit size ⁶	Airflow cfm (L/S)	Water flow gpm (L/S)	Voltage	Water loop				Ground loop				Dimensions L x W x H, in (mm)
				Cooling ²		Heating ³		Cooling ⁴		Heating ⁵		
				Btu/hr (Watts)	EER ¹	Btu/hr (Watts)	COP ¹	Btu/hr (Watts)	EER ¹	Btu/hr (Watts)	COP ¹	
072	2300 (1085)	18.5 (1.17)	208-60-3 230-60-3 460-60-3 575-60-3	72,800 (21,317)	13.1	88,500 (25,914)	4.6	74,500 (21,814)	14.6	59,100 (17,305)	3.4	54 5/8 x 28 x 55 3/4 (1387 x 711 x 1416)
096	3600 (1699)	22.2 (1.4)	208-60-3 230-60-3 460-60-3 575-60-3	86,500 (25,328)	13.0	100,800 (29,515)	4.7	89,200 (26,119)	14.6	69,700 (20,409)	3.6	
120	4000 (1888)	30.0 (1.89)	208-60-3 230-60-3 460-60-3 575-60-3	119,700 (35,049)	14.0	150,200 (43,980)	5.3	123,200 (36,074)	15.9	98,000 (28,695)	3.9	
180	6000 (2832)	46.0 (2.9)	208-60-3 230-60-3 460-60-3 575-60-3	189,200 (55,400)	14.9	209,800 (61,432)	4.9	191,200 (55,985)	14.7	132,000 (38,651)	3.6	80 1/4 x 30 x 67 (2038 x 762 x 1702)
215	7167 (3382)	54.0 (3.4)	208-60-3 230-60-3 460-60-3 575-60-3	220,800 (64,653)	14.2	254,800 (74,608)	4.9	229,200 (67,112)	16.3	147,600 (43,219)	3.7	
290	9670 (4564)	80.0 (5.04)	208-60-3 230-60-3 460-60-3 575-60-3	308,800 (90,420)	11.0	422,100 (123,595)	4.1	322,400 (94,402)	12.4	260,728 (76,344)	3.3	

2. Water Loop cooling capacity is based on 80.6°F db, 66.2°F wb entering air temperature and 86°F entering water temperature.

3. Water Loop heating capacity is based on 68°F entering air temperature and 68°F entering water temperature.

4. Ground Loop cooling capacity is based on 80.6°F db, 66.2°F wb entering air temperature and 77°F entering water temperature.

5. Ground Loop heating capacity is based on 68°F entering air temperature and 32°F entering water temperature.

6. Vertical unit sizes 180 through 290 are not AHRI certified since they exceed 135,000 Btu/hr for standard 320.S.

WLVC and WLVW Features and Options

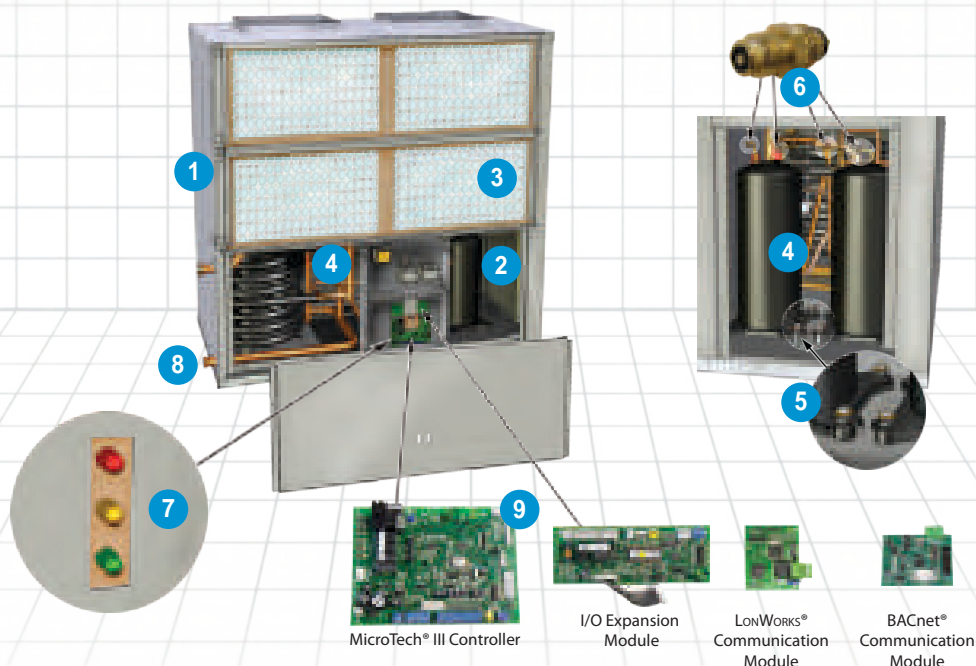

1 Cabinets

- Heavy gauge G-60 galvanized steel

2 Insulation

- All interior framework and panels are lined with 1/2" thick, 1½ lb. dual-density fiberglass insulation. Optional (IAQ) closed-cell foam insulation

3 Filter

- Standard 1" factory-installed filter rack with 1" throwaway filter. Optional field-installed 2" filter rack with duct collar

4 Refrigerant circuit

- Dual circuit with scroll compressors for maximum efficiency

5 Compressor vibration isolators

- Standard feature for all units, reduces vibration sound levels during compressor operation

6 CoreMax service valves

- Four CoreMax service valves—one on the low side and one on the high side of each refrigeration circuit—for charging and service

7 LED annunciator

- External LED status lights display fault conditions to provide easy diagnosis and troubleshooting, visible without removing access panel

8 External pipe connections

- Supply and return pipe connections, outside the cabinet, make pipe connections easy

9 MicroTech® III controllers

- Open Choices™ feature allows standalone or easy, low cost network integration using LonWorks® or BACnet® communication options

Condensate Overflow Protection (not shown)

- Low and high refrigerant pressure switches and low refrigerant suction temperature (freezestat) sensor

Two or three-fan units and multiple discharge air arrangements

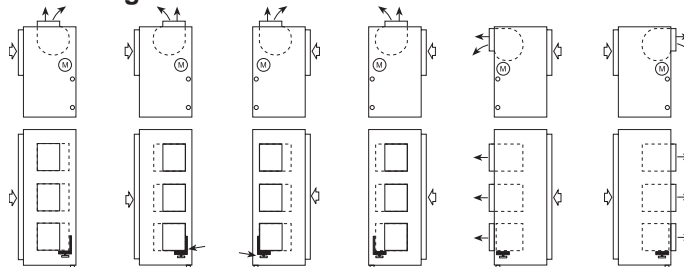

Rooftop Outdoor Curb-Mounted—12 to 35 Tons

- Flexible downflow and horizontal discharge arrangements
- Standard or geothermal application flexibility
- Heavy duty cabinet construction and full perimeter roof curb for long life
- Multiple access panels for easy maintenance
- Sloped stainless steel drain pan for superior IAQ
- Multiple refrigerant circuits on all units for staged operation
- Economizer, hot gas bypass and reheat, and fan motor size options to meet application requirements
- R-410A refrigerant

For more detail, refer to Catalog 1106.

For the most current information, refer to DaikinApplied.com.



Standard Range (Water Loop) Models:

- WRWA - Downflow Discharge and Return
- WRWC - Horizontal Discharge and Return

Geothermal Range (Ground Loop) Models:

- WRGA - Downflow Discharge and Return
- WRGC - Horizontal Discharge and Return

Water Source Heat Pumps

Physical Data—Rooftop Outdoor Curb-Mounted

Unit Dimensions—WRWA, WRGA, WRWC and WRGC Units

Dimensions, inches (mm)							
	150	180	210	200	300	360	420
RWA, RGA Downflow Discharge							
Length							
Width ⁽¹⁾	97.0 (2464)	97.0 (2464)	97.0 (2464)	130.75 (3321)	130.75 (3321)	130.75 (3321)	130.75 (3321)
Width ⁽²⁾	82.5 (2096)	82.5 (2096)	82.5 (2096)	112.56 (2859)	112.56 (2859)	112.56 (2859)	112.56 (2859)
Height	62.0 (1575)	62.0 (1575)	62.0 (1575)	83.0 (2108)	83.0 (2108)	83.0 (2108)	83.0 (2108)
RWC, RGC Horizontal Discharge							
Length							
Width ⁽¹⁾	107.75 (2737)	107.75 (2737)	107.75 (2737)	146.63 (3724)	146.63 (3724)	146.63 (3724)	146.63 (3724)
Width ⁽²⁾	82.5 (3321)	82.5 (3321)	82.5 (3321)	112.5 (2858)	112.5 (2858)	112.5 (2858)	112.5 (2858)
Height	62.0 (1575)	62.0 (1575)	62.0 (1575)	83.0 (2108)	83.0 (2108)	83.0 (2108)	83.0 (2108)

(1) with intake hood
(2) without intake hood

Roof Curb Dimensions—WRWA, WRGA, WRWC and WRGC Units

Unit size	Length, in (mm)	Width, in (mm)	Height, in (mm)
150	79.0 (2007)	54.093 (1374)	14.0 (356)
180	79.0 (2007)	54.093 (1374)	14.0 (356)
210	79.0 (2007)	54.093 (1374)	14.0 (356)
200	109.0 (2769)	58.813 (1494)	14.0 (356)
240	109.0 (2769)	58.813 (1494)	14.0 (356)
300	109.0 (2769)	58.813 (1494)	14.0 (356)
360	109.0 (2769)	58.813 (1494)	14.0 (356)
420	109.0 (2769)	58.813 (1494)	14.0 (356)

Water Source Heat Pumps

Performance Data—Rooftop Outdoor Curb-Mounted

WRWA, WRWC Water Loop and WRGA, WRGC Ground Loop Units

Unit size	Airflow cfm (L/S)	Water flow gpm (L/S)	Voltage	Water loop ²				Ground loop ³			
				Cooling		Heating		Cooling		Heating	
				Btu/hr (Watts)	EER ¹	Btu/hr (Watts)	COP ¹	Btu/hr (Watts)	EER ¹	Btu/hr (Watts)	COP ¹
150	5000 (2360)	31.3 (1.97)	208-230/60/3 460/60/3	164,390 (11,033)	14.9	198,666 (58,175)	5.3	171,048 (10,175)	16.8	128,646 (37,671)	3.8
180	6000 (2832)	37.5 (2.37)	208-230/60/3 460/60/3	199,072 (13,361)	14.9	241,608 (70,750)	5.2	206,992 (12,395)	16.7	155,900 (45,652)	4.0
210	6000 (2832)	43.8 (2.76)	208-230/60/3 460/60/3	222,472 (14,541)	15.3	265,856 (77,851)	5.5	231,598 (13,465)	17.2	167,484 (49,044)	4.0
200	6000 (2832)	41.7 (2.63)	208-230/60/3 460/60/3	225,066 (14,245)	15.8	264,276 (77,388)	5.3	234,082 (13,225)	17.7	167,404 (49,021)	4.0
240	8000 (3776)	50.0 (3.15)	208-230/60/3 460/60/3	263,654 (16,076)	16.4	298,834 (87,508)	5.6	274,346 (14,830)	18.5	190,026 (55,645)	4.2
300	10,000 (4720)	62.5 (3.94)	208-230/60/3 460/60/3	358,174 (25,768)	13.9	439,652 (128,743)	4.9	372,950 (23,922)	15.6	285,872 (83,712)	3.8
360	12,000 (5663)	75.0 (4.73)	208-230/60/3 460/60/3	414,688 (28,999)	14.3	497,222 (145,602)	4.9	430,604 (27,082)	15.9	315,926 (92,513)	3.7
420	12,000 (5663)	87.6 (5.53)	208-230/60/3 460/60/3	477,606 (32,490)	14.7	583,648 (170,910)	5.0	496,578 (30,096)	16.5	373,286 (109,309)	3.8

1. EER = Energy Efficiency Ratio; COP = Coefficient of Performance.

2. Cooling capacity is based on 80.6°F (27°C) db, 66.2°F (19°C) wb entering air temperature and 86°F (30°C) entering, 95°F (35°C) leaving water temperature. Heating capacity based on 68°F (20°C) db entering air temperature and 68°F (20°C) entering water temperature. Net capacities include fan motor heat; 50 cycle units are de-rated, 60 cycle units.

3. Cooling capacity is based on 80.6°F (27°C) db, 66.2°F (19°C) wb entering air temperature and 77°F (25°C) entering, 87°F (31°C) leaving water temperature. Heating capacity based on 68°F (20°C) db entering air temperature and 32°F (0°C) entering water temperature. Net capacities include fan motor heat; 50 cycle units are de-rated, 60 cycle units.

Water Source Heat Pumps

Vertical Stack Water Source Heat Pumps—3/4 to 3 Tons

- R-410A refrigerant with no ozone depletion potential or phase-out date
- Superior indoor air quality and quiet operation
- Multiple unit sizes – 009 (3/4 ton, 2.6kW) through 036 (3 ton, 10.6kW)
- Units exceed ASHRAE 90.1 efficiency levels
- MicroTech® III unit controls with Open Choices™ feature allows standalone or easy, low cost network integration using LONWORKS® or BACnet® communication options
- Performance rated with ISO Standard 13256-1
- ECM motor (021–036)

For more detail, refer to Catalog 1105.

For the most current information, refer to DaikinApplied.com.



Enfinity™
Model WVHF - Cabinet
Model WVHC - Chassis



Performance Data—Water Loop

Unit size	Airflow		Water flow		Voltage	Standard Unit						ECM at High Static							
	cfm	L/S	GPM	L/S		Cooling				Heating		Cooling				Heating			
						Btu/h	Watts	EER	COP	Btu/h	Watts	COP	Btu/h	Watts	EER	COP	Btu/h	Watts	COP
009	450	212	2.5	0.16	115-1-60 208/230-1-60 265-1-60	9800	2870	14.4	4.2	11000	3230	5.0	N/A	N/A	N/A	N/A	N/A	N/A	N/A
012	450	212	3.0	0.19	115-1-60 208/230-1-60 265-1-60	11700	3430	13.6	4.0	14700	4306	5.2	N/A	N/A	N/A	N/A	N/A	N/A	N/A
015	500	236	3.5	0.22	208/230-1-60 265-1-60	14000	4200	14.5	4.2	18100	5300	5.0	N/A	N/A	N/A	N/A	N/A	N/A	N/A
018	500	236	4.2	0.26	208/230-1-60 265-1-60	16800	4900	13.6	4.0	21200	6300	4.3	N/A	N/A	N/A	N/A	N/A	N/A	N/A
018	500	236	4.2	0.26	208/230-1-60 265-1-60	16800	4900	13.6	4.0	21200	6300	4.3	N/A	N/A	N/A	N/A	N/A	N/A	N/A
021	760	359	5.4	0.34	208/230-1-60	21500	6200	14.2	4.2	26700	7900	5.1	21500	6200	14.5	4.3	26700	7800	5.2
024	760	359	6.0	0.38	208/230-1-60 265-1-60	24400	7200	15.1	4.4	29000	8400	4.9	24400	7100	15.4	4.5	29000	8400	5.0
030	1100	519	7.3	0.46	208/230-1-60 265-1-60	29100	8500	15.2	4.5	35700	10400	4.9	29100	8500	15.4	4.5	35700	10400	5.0
036	1100	519	9.0	0.57	208/230-1-60 265-1-60	35400	10400	14.1	4.1	44900	13100	4.3	35400	10300	14.2	4.2	44900	13200	4.3

N/A = Not Available

Size 007 available, please contact your Daikin representative for details.



WVHF and WVHC Features and Options

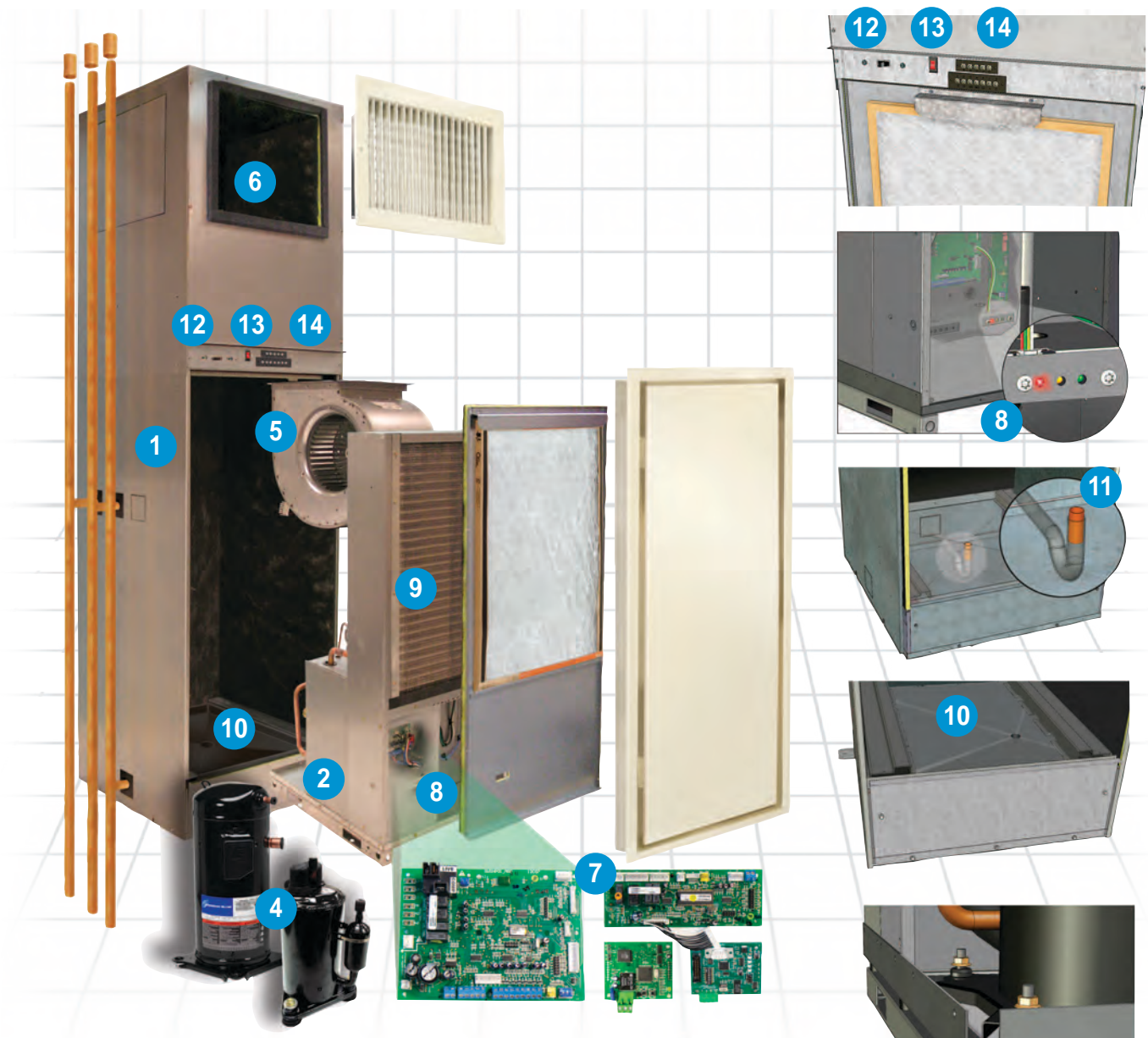

The optional Remote Control Node (RCN) interfaces with the Vertical Stack unit, and communicates with the T9000 wireless temperature control thermostat using unlicensed 900 MHz, radio frequency energy.



The T9000 Wireless Temperature Control provides precision temperature control thermostat without the installation labor and expense of wiring

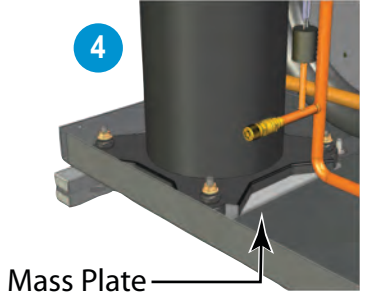
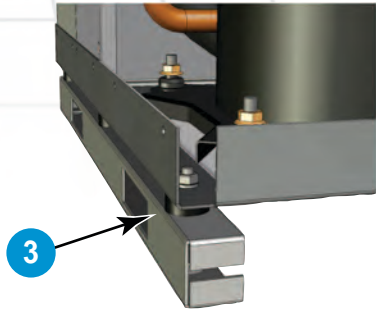

WVHF and WVHC Features and Options

- 1 Compact cabinets**
 - Constructed of unpainted galvanized steel, with the smallest possible footprint. 18" x 18" cabinet for unit sizes 009 through 018 and 24" x 24" for unit sizes 021 through 036
- 2 Chassis**
 - Removable, allows staged installation and ease of service and routine maintenance
- 3 Chassis vibration isolators**
 - Vibration isolators are integral to the chassis support rails to help minimize noise and vibration transmission resulting in a quiet occupied space
- 4 Compressors**
 - High efficiency rotary and scroll, available with optional mass plate and/or compressor sound blanket (scroll compressor only) for quiet operation (unit sizes 021-036)
- 5 Motor/blower assembly**
 - PSC standard fan motor and housing is removable and slides out through the front of the cabinet. Optional ECM motor available in unit sizes 021-036
- 6 Supply air plenum**
 - Allows for multiple discharge air configurations
- 7 Microtech® III control system**
 - Open Choices™ feature allows standalone or easy, low cost network integration using LonWorks® or BACnet® communication options
- 8 LED annunciator**
 - LED status lights display fault conditions to provide easy troubleshooting and diagnosis. Accessed by opening the front panel
- 9 Primary condensate drain pan**
 - Is sloped and constructed of a corrosion resistant ABS plastic. It sits below the air coil to capture all condensate in cooling mode. A factory installed condensate overflow sensor disables unit operation when the condensate level reaches the sensor
- 10 Secondary IAQ condensate drain pan**
 - Sits below the chassis to prevent condensate or other liquids from dripping into the cabinet and possibly reaching the living space. Available in optional corrosion resistant stainless steel or standard galvanized steel. This drain pan also includes a factory installed condensate overflow sensor
- 11 Condensate drain hose IAQ J-trap**
 - Formed, flexible condensate trap helps prevent undesirable odors from backing up into the unit and into the supply air stream
- 12 Front-mounted disconnect switch**
 - Easy-access disconnect switch allows the user to turn off power to the unit for service/maintenance
- 13 Two-speed fan toggle switch**
 - Convenient location for easy high/low fan speed change
- 14 Front-mounted thermostat terminal strip**
 - Provides easy connection of wall-mounted thermostat

WVHF and WVHC Accessories

2-way motorized valves

Ideal in variable pumping applications. On a call for cooling or heating the valve opens providing full water flow prior to compressor operation.



Shutoff valves

Factory-mounted and brazed to the unit supply and return risers. They have FPT connections for connecting flexible supply and return hoses.



Stainless steel braided hoses

Fire rated construction in lengths of 48" and 36". Threaded connections of 1/2" (13 mm) to match the MPT fittings on unit sizes 009-018 and 3/4" (19 mm) to match the MPT fittings on unit sizes 021-036.



Supply air diffuser

Double-deflection or double-deflection with adjustable damper.



Hinged return air grille

Constructed of heavy gauge steel, lined with insulation to help attenuate sound. Electrostatic powder coat finish, in Antique Ivory or Cupola White.



Console In-Room—1/2 to 1 1/2 Tons

- Standard or geothermal application flexibility
- High efficiency reduces energy consumption/operating costs and can contribute to earning LEED® points and rebates
- R-410A refrigerant with no ozone depletion potential or phase-out date
- GentleFlo™ cross-tangential fan wheel design provides whisper quiet operation and maximum airflow for proper air circulation
- MicroTech® III unit controls with Open Choices™ feature allows standalone or easy, low cost network integration using LONWORKS® or BACnet® communication options
- Two cabinet styles – flat top or slope top in high or low sill configuration to satisfy special application requirements
- Performance rated with ISO Standard 13256-1

For more detail, refer to Catalog 1104.

For the most current information, refer to DaikinApplied.com.



Flat top unit

Enfinity™ model WMHC, standard range



Enfinity™ model WMHW, extended range/geothermal

Slope top unit



Performance Data—Enfinity™ Console In-room Models WMHC and WMHW

Unit size	Airflow		Water flow		Water loop - standard unit						Ground loop - ECM @ high static						Dimensions L x W x H (in.) Low Sill & High Sill		
	cfm	L/S	GPM	L/S	Cooling ¹ 86°F (30°C)			Heating ² 68°F (20°C)			Cooling ¹ 77°F (25°C)			Heating ² 32°F (0°C)					
					Btu/hr	Watts	EER	COP	Btu/hr	Watts	COP	Btu/hr	Watts	EER	COP	Btu/hr		Watts	COP
007	273	129	1.93	0.122	7718	518	14.9	4.4	9109	526	5.1	8365	474	17.7	5.2	5605	495	3.3	46x10.25x22.5 46x10.25x25
009	347	164	2.4	0.15	9170	651	14.1	4.1	11,000	686	4.7	9730	602	16.2	4.7	7030	627	3.3	
012	275	130	2.9	0.18	11,600	776	14.9	4.4	13,900	894	4.6	12,300	700	17.5	5.1	9000	780	3.4	54x10.25x22.5 54x10.25x25
015	559	264	3.7	0.23	14,500	964	15.1	4.4	18,200	1031	5.2	15,400	885	17.3	5.1	10,900	940	3.4	
018	421	199	4.6	0.29	16,400	1223	13.4	3.9	13,700	4010	3.5	19,700	5770	19.0	5.6	13,400	3920	3.7	

Table notes:

CFM = Cubic Feet per Minute; L/S = Liters per second; GPM = Gallons Per Minute; Btu/hr = BTU per hour; EER = Energy Efficiency Ratio; COP = Coefficient of Performance

1. Cooling capacity is based on 80.6°F db. 66.2°F wb. (27/19°C) entering air temperature and 86°F (30°C) entering water temperature.

2. Heating capacity is based on 68°F (20°C) entering air temperature and 68°F (20°C) entering water temperature.

WMHC and WMHW Features and Options

I/O Expansion Module



MicroTech® III Controller



LONWORKS® Module



BACnet® Module

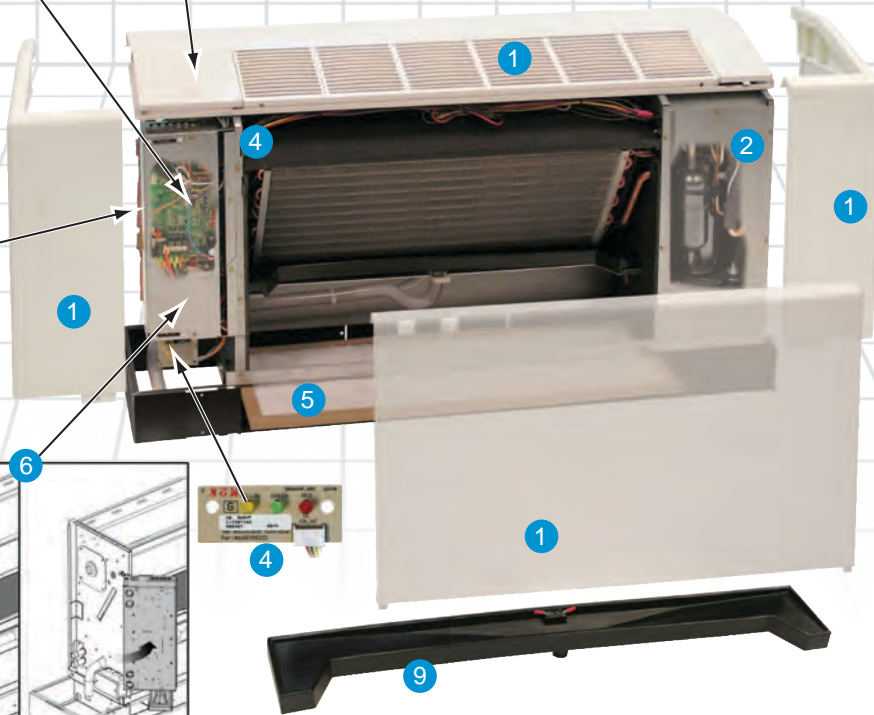
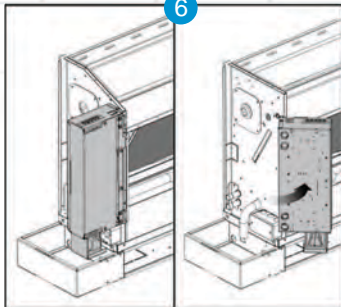
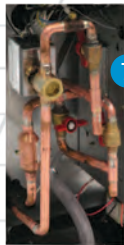

Multi-directional Grille



Extended Cabinet End Pocket

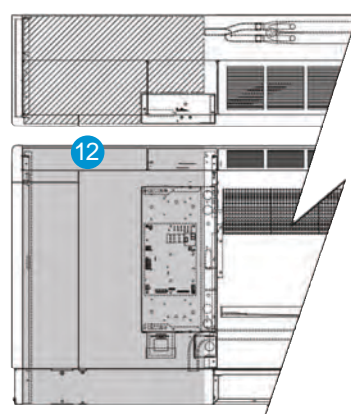

WMHC and WMHW Features and Options

1 Cabinets

- Selectable flat top or angled top cabinet configuration with multiple grille options
- Individual – top, front and end panels for easy removal and access to unit components for service and maintenance

2 Compressor

- High efficiency rotary type, using R-410A refrigerant with zero ozone depletion potential or phase-out date

3 Gentleflo™ fan

- User selectable, multi-speed tangential fan system provides high efficiency and very quiet operation

4 LED status lights

- Display fault conditions to provide easy troubleshooting and diagnosis

5 Filter

- 1/2" (12.7mm) disposable filter that is easy to access and replaced from the front of the unit without removing a panel

6 Hinged control box

- Provides added accessibility to plumbing end compartment for easy service

7 MicroTech® III unit controller

- Open Choices™ feature allows standalone or easy, low cost network integration using LONWORKS® or BACnet® communication options

8 2-way motorized valve packages (optional)

- Factory installed or field-installed for variable pumping applications. Other valve options available upon request. Two-way isolation valves open only on a call for heating or cooling, saving on operating costs

9 Double-sloped drain pan

- Made of durable, noncorrosive polymer, promotes positive condensate drainage for superior Indoor Air Quality (IAQ). Drain Pan is easy to remove for cleaning

10 Wireless temperature control (optional)

- *Factory or Field-installed* for units set up for unit-mounted 24V thermostat control. The Remote Control Node (RCN) interfaces with specific HVAC equipment and communicates with its thermostat
- *The Remote Control Node (RCN)* interfaces with the console unit, and communicates with the T9000 wireless temperature control using unlicensed 900 MHz, radio frequency energy
- *The T9000 Wireless Temperature Control* provides precision temperature control without the installation labor and expense of wiring



Wireless control skin attached

Wireless remote control node (RCN)



T9000 wireless thermostat

11 Optional multi-directional grilles

- Selectable plastic Multi-Directional Grilles can be rotated for added control of discharge air direction

12 Optional extended end pockets (high sill units)

- Provides 11" of additional area inside the left or right end pocket for piping or a field-installed pump

Air dampers (optional - not shown)

- Motorized or manually operated outside air dampers provide ventilation air

Optional 7" high subbase

- Allows increased flexibility for piping arrangements

Water to Water Floor-Mounted—3 to 35 Tons

- Heating only, cooling only or heating and cooling models
- High efficiency and quiet operation
- Large panels for accessibility to compressor and controls sections
- Flexible configurations with top or side piping (120–420)
- Flexible configurations with front or side control box (120–420)
- Status lights—compressor 1, compressor 2, fault (120–420)
- Domestic hot water coil (036–072)
- R-410A refrigerant

For more detail, refer to Catalog 1107.

For the most current information, refer to DaikinApplied.com.



Model WWRA—extended range heating and cooling models

Model WWHA—extended range heating only models

Model WWCA—extended range cooling only models

Physical Data—Water to Water Floor-Mounted

Model sizes	Btuh nominal cooling	Cabinet dimensions, inches			Water connections, inches	
		Width	Depth	Height	Load/source	Domestic hot water
036	36,000	28-1/8	28-1/8	19	3/4 FPT	1/2 FPT
048	48,000	28-1/8	28-1/8	21	1 FPT	1/2 FPT
060	60,000	28-1/8	28-1/8	21	1 FPT	1/2 FPT
072	72,000	35-1/8	28-1/8	21	1 FPT	1/2 FPT
120	120,000	34	42	41	1-1/2	N/A
150	150,000	34	42	41	1-1/2	N/A
180	180,000	34	42	41	1-1/2	N/A
240	240,000	34	50	63-1/8	2	N/A
300	300,000	34	50	63-1/8	2	N/A
360	360,000	34	50	63-1/8	2	N/A
420	420,000	34	50	63-1/8	2	N/A

Products manufactured in ISO certified facilities.

Warranty

All Daikin equipment is sold pursuant to Daikin's Standard Terms and Conditions of Sale and Limited Product Warranty.



800.432.1342
www.DaikinApplied.com

™® The following are tradenames or registered trademarks of their respective companies: BACnet from ASHRAE; Modbus from Schneider Electric Ltd; MicroTech III, Open Choices, from Daikin; LONMARK, LONTALK, and LONWORKS are managed, granted and used by LONMARK International under a license granted by Echelon Corporation.

©2013 Daikin Applied
A/SP 31-29 (03/13)